



CANOPIA[®]
by PALRAM

HOW TO ASSEMBLE

ANCHORING KIT

Suitable for: Snap&Grow

IMPORTANT!

Please read these instructions carefully before starting assembly.
Keep these instructions in a safe place for future reference.

www.canopia.com

A member of Palram Industries Ltd.

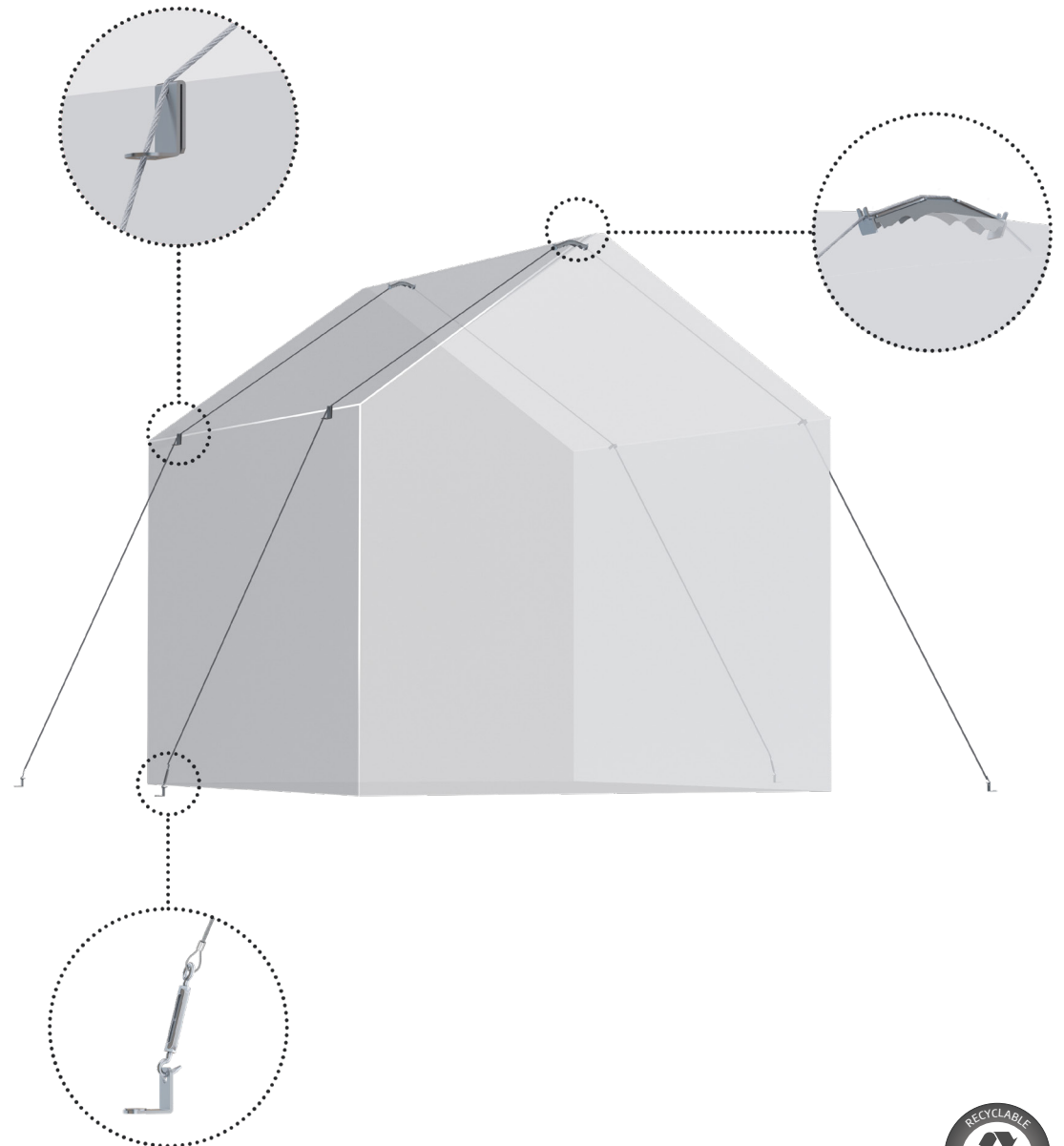

83192_22.10_MV

HAVE A CONCERN? WE CAN HELP.

Before returning your purchase:

You didn't find what you
were looking for?
We can help at
canopia.shop/support

Still can't find what you
are looking for?
Please see next page for
local customer care.

HABEN SIE BEDENKEN? WIR KÖNNEN HELFEN.

Bevor Sie Ihren Kauf zurücksenden:

Haben Sie nicht gefunden,
wonach Sie gesucht haben?
Unter canopia.shop/support
können wir helfen.

Sie haben noch nicht
gefunden wonach Sie suchen?
Auf der nächsten Seite
finden Sie den Kontakt zu
unserem lokalen Kundendienst.

TIENE ALGUNA INQUIETUD? PODEMOS AYUDARLE.

Antes de retornar su compra:

No encontró lo que
estaba buscando?
Podemos ayudarle en
canopia.shop/support

Aún no encontró lo que buscaba?
Por favor vea en la siguiente
página el Servicio Local al Cliente.

UN SOUCI? UNE QUESTION? NOUS POUVONS VOUS AIDER.

Avant de renvoyer ce produit:

Vous n'avez pas trouvé
ce que vous cherchez ?
Nous pouvons vous aider sur
canopia.shop/support

Insatisfait/e ou sans réponse ?
Merci de contacter notre Service
Client local ci-dessous.





WE ARE HERE TO HELP

For general questions: canopia.com/contact-us

NORWAY • SWEDEN • ARGENTINA • GREECE • GREENLAND • ICELAND • ESTONIA • JAPAN • LATVIA • LITHUANIA
MAURITIUS • MEXICO • ROMANIA • RUSSIA • TURKEY • UZBEKISTAN • UKRAINE • SWAZILAND • KOREA

+972-4-848-6816 | customer.service@palram.com

USA	CANADA	HUNGARY • SLOVAKIA
877-627-8476 generalsupport@poly-tex.com	905-5646007 sales@footprintproducts.com	+420-493-523-523 servis@garland.cz
UNITED KINGDOM • IRELAND	GERMANY	NEW ZEALAND
01302-380775 customer.serviceUK@palram.com	0180-522-8778 customer.serviceDE@palram.com	0800 800 880 customer.service@palram.com
FRANCE • BELGIUM	ISRAEL	DENMARK
+33-169-791-094 customer.serviceFR@palram.com	04-848-6800 customer.service@palram.com	07-575 42 70 post@nshnordic.com
ITALY • NETHERLANDS • PORTUGAL • SPAIN	AUSTRIA • LUXEMBURG • LIECHTENSTEIN	SOUTH AFRICA
+33-169-791-094 customer.serviceFR@palram.com	+49-180-522-8778 customer.serviceDE@palram.com	011-397-7771 receptionza@palram.com
AUSTRALIA	AUSTRALIA - GREENHOUSES	CROATIA • SLOVENIA
03-9219-4444 salesvic@palram.com	03-9544-6-999 info@mazedistribution.com.au	0599-37-057 info@ms-viscom.com
CZECH REPUBLIC	SWITZERLAND	POLAND
0493-523-523 servis@garland.cz	062-287-33-77 info@ritter.ch	Infolinia: 801-011-929 22-349-93-36 kontakt@ogrodosfera.pl
CYPRUS	FINLAND	
0224-971-13 alpaco@alpacodomatica.com www.alpacodomatica.com	Neuvonta: 09-6866720 Tuki / Varaosat: 050-3715350 www.horizontenterprises.fi tuki@horizontenterprises.fi	

SAFETY ADVICE

- It is of utmost importance to assemble all of the parts according to the directions. Do not skip any steps.
- Always wear work gloves during panel sliding.
- Always wear shoes and safety goggles when working with extruded aluminium.
- If using a step ladder or power tools make sure that you follow the manufacturer's safety advice.
- Do not touch overhead power cables with the aluminium profiles.
- Do not attempt to assemble the product in windy or wet conditions.
- Do not climb or stand on the roof.
- Dispose of all plastic bags. Keep them out of reach of small children.
- Keep children away from the assembly area.
- Do not lean against or push the products during construction.
- Do not position your product in an area exposed to excessive winds.
- Do not attempt to assemble this product if you are tired, have taken drugs or alcohol or if you are prone to dizzy spells.
- Hot items such as recently used grills, blowtorches etc. must not be stored in the product.
- Make sure there are no hidden pipes or cables in the ground before anchoring to foundation.
- **Make sure to anchor the product directly to a solid foundation to increase the product's stability and wind resistance in areas with severe weather conditions.**
Make sure that there are no obstructions between the assembly area and the final position of the product.

CARE & MAINTENANCE

- When your product needs to be cleaned, use a mild detergent solution and rinse with cold clean water.
- DO NOT use acetone, abrasive cleaners or other special detergents to clean the panels.
- Clean the product once assembly is complete.

BEFORE ASSEMBLY

- Selecting a site:
 - Choose your site carefully before beginning assembly.
 - Choose a sunny position away from overhanging trees.
 - The product must be positioned and fixed on a flat level surface.
- The product must be secured directly to a solid foundation.
- This is a multi-part assembly best achieved by two people. Allow at least half a day for the assembly process.
- Take all components & parts out of the packages. Sort the parts and check against the content parts list.
- Parts should be laid out close at hand. Keep all small parts (screws etc.) in a bowl so they do not get lost.
- Please note multi-sided profiles are used in this product. As a result some holes in the profiles are not used during assembly.
- Please review entire instructions before starting. Carry out the assembly steps in exact order.
- Please consult your local authorities if any permits are required prior to constructing the product.
- **This product is suitable for all Snap&Grow greenhouses up to 8 feet long.**

IMPORTANT!

- Firmly connect the product to a level surface immediately after completion of the assembly.
- Anchoring this product to the ground is essential to its stability and rigidity. It is required to complete this stage in order for your warranty to be valid.
- During assembly use a soft surface below the parts to avoid scratches and damages.

TOOLS & EQUIPMENT

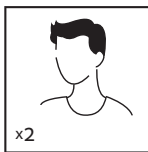

2 people needed

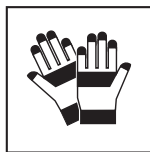

Work gloves



Wrench



Needle Nose Pliers

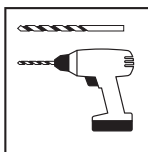

Electric Drill
With Drill Bit



Ladder

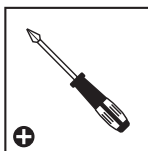

Philips head
Screwdriver

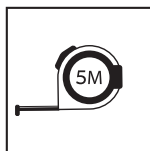

Tape measure

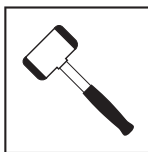

Rubber Mallet



IMPORTANT ASSEMBLY STEPS

When encountering this information icon during assembly, please refer the relevant assembly step for important additional comments.

Do not cut the steel cable unless a final decision on the mounting location has been made.

Step 3: According to the ground surface type, follow the appropriate mounting procedure.

Option 1: for hard surfaces (concrete or wood).





Option 2: soft/ground installation.

Step 5: After the product has been installed, fasten the steel cable by turning part #7332.

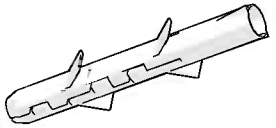
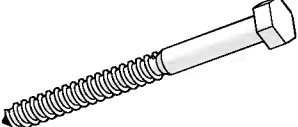
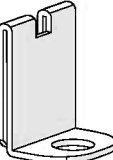
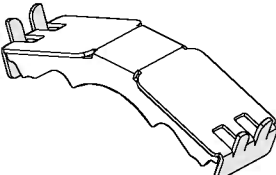
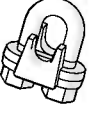
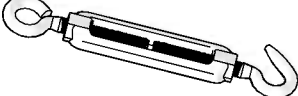
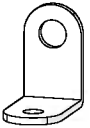
Tighten all screws when completing assembly.

Contents

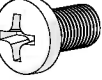
Item		Qty.
4010		4 (+1)
4000		4 (+1)
7409		4
7410		2
7333		4
7332		2
7331		4

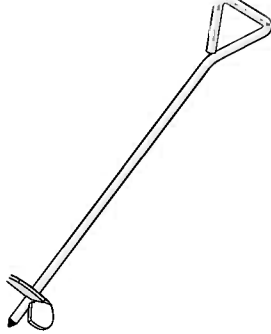
Item		Qty.
414		2 (+1)
433		6 (+1)
7283		2 (+1)
7327		2
7336		4

1

7327.....

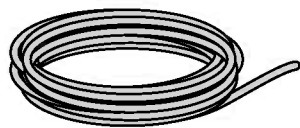

..... 2

7410.....

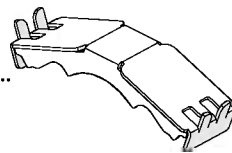

..... 2

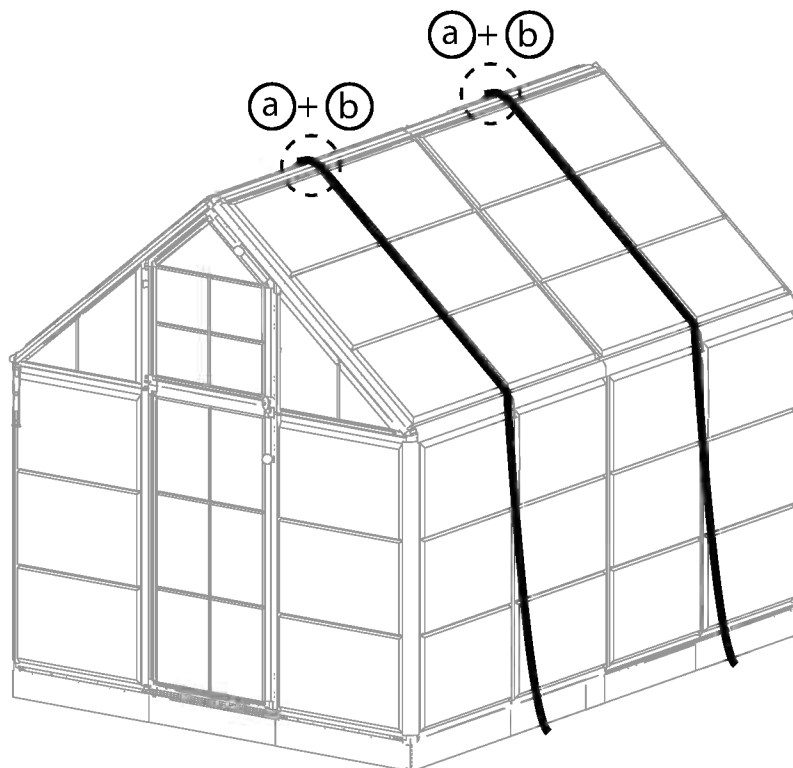

a

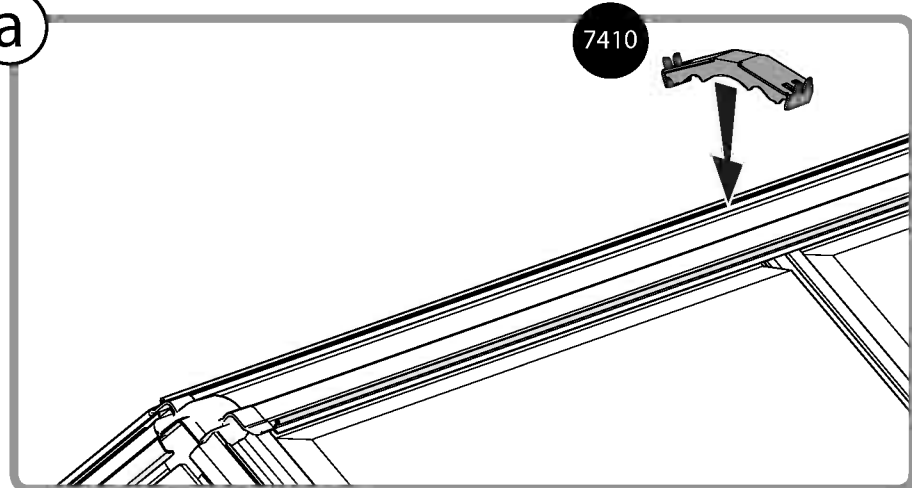

b

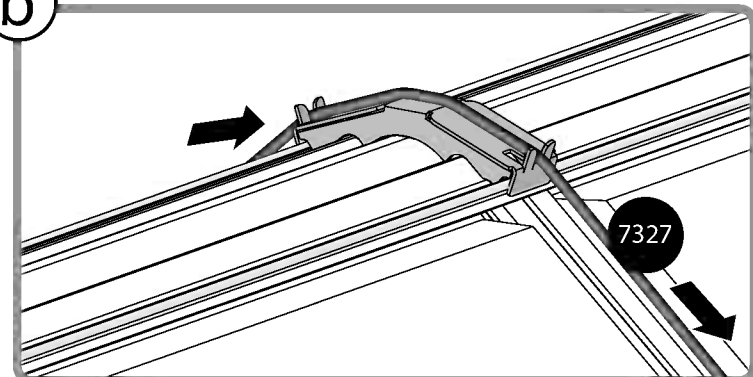

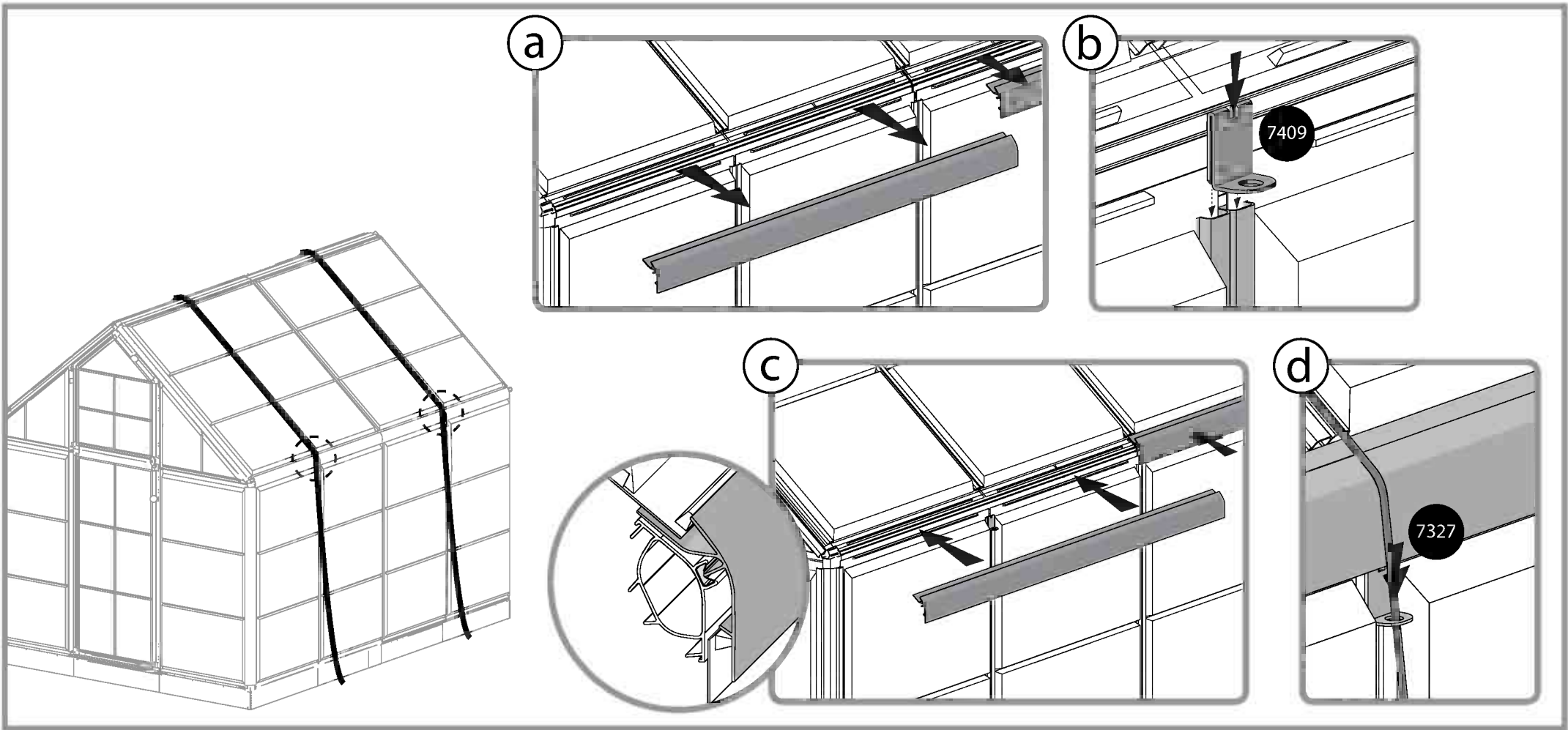
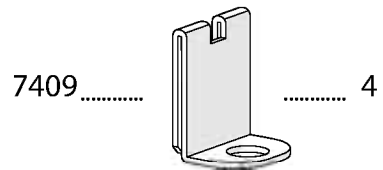

3 **i**

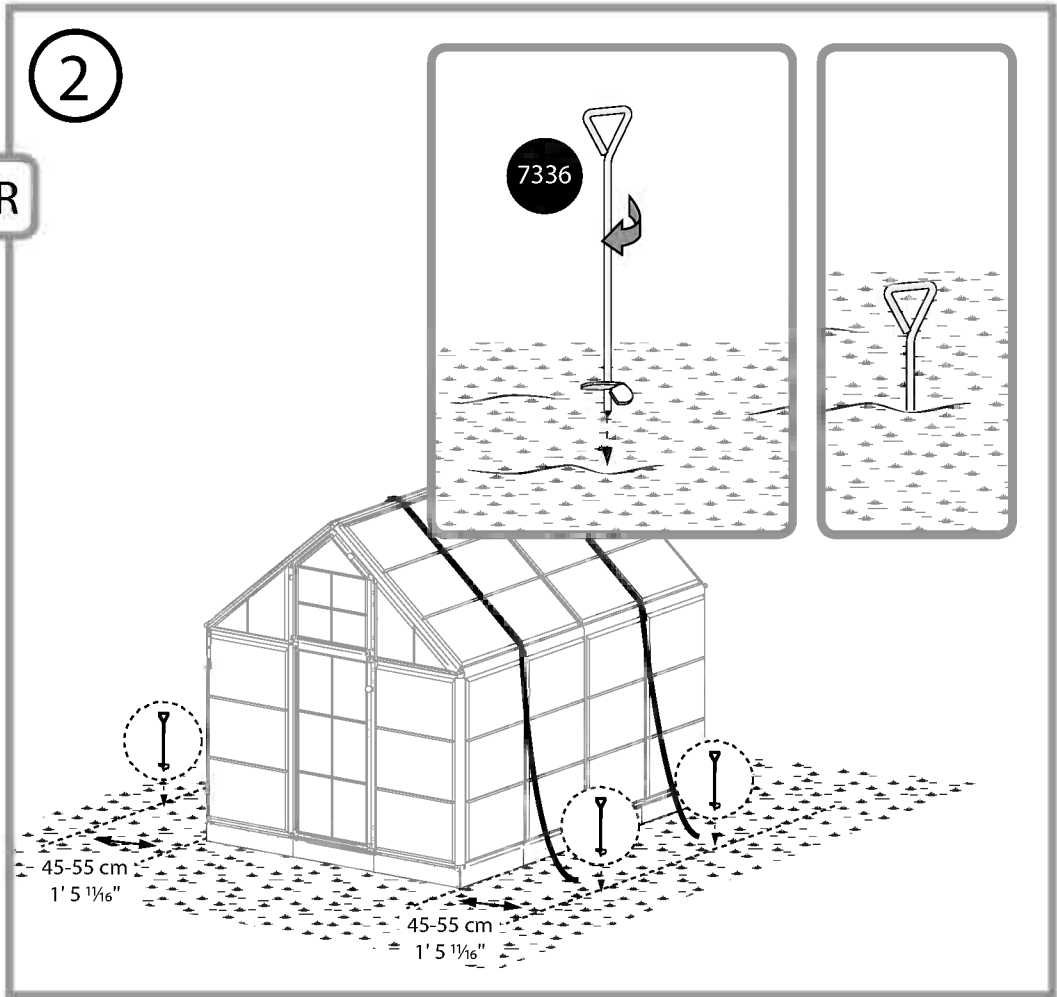
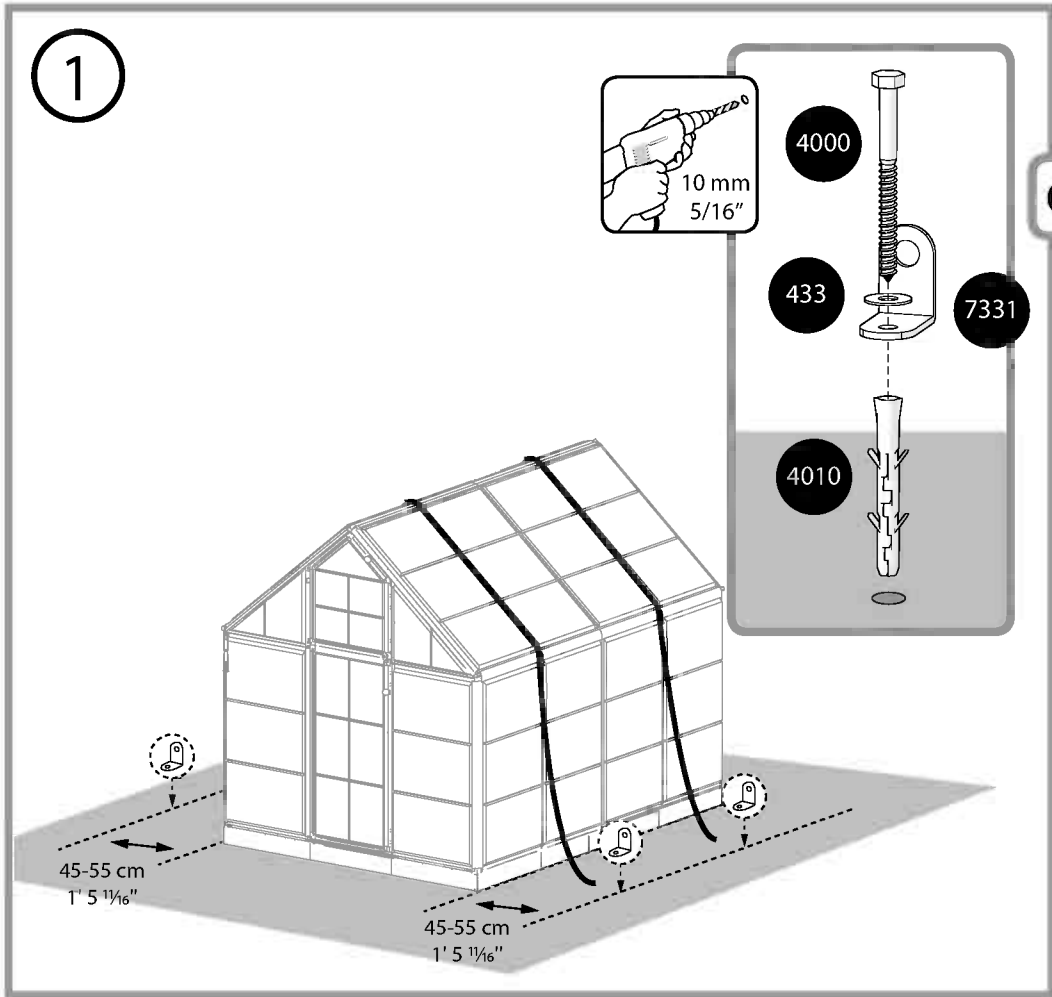
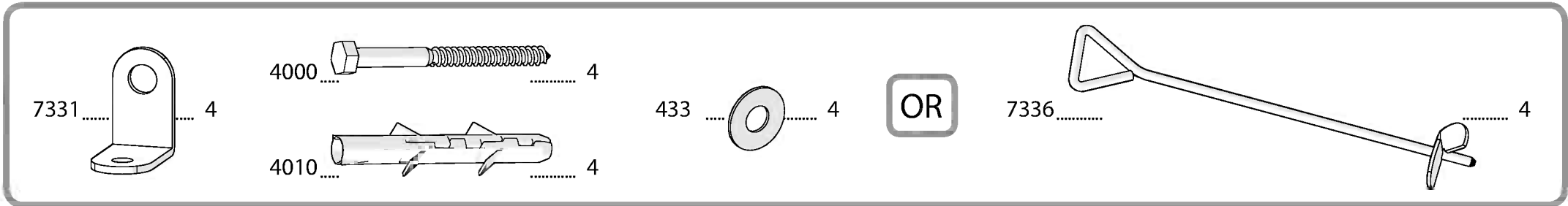

- 7333..... 2 7283..... 2 414 2 433 2

1

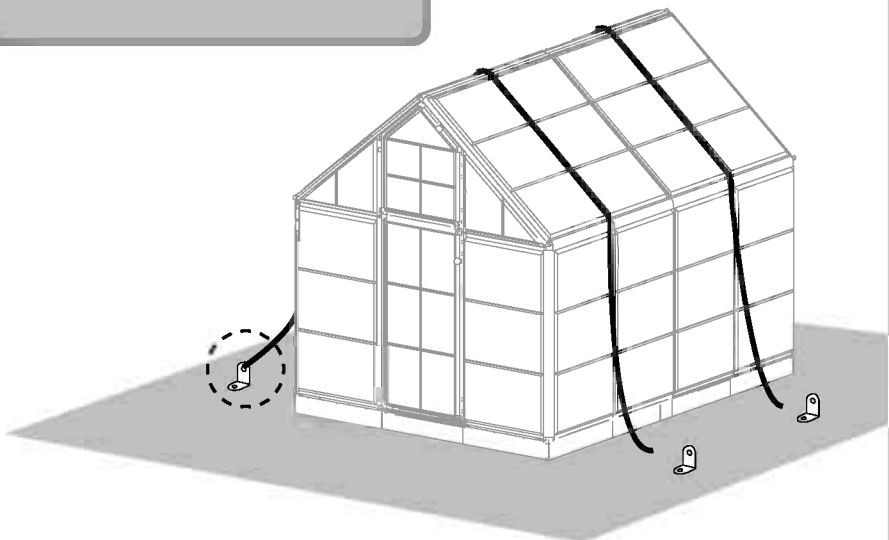
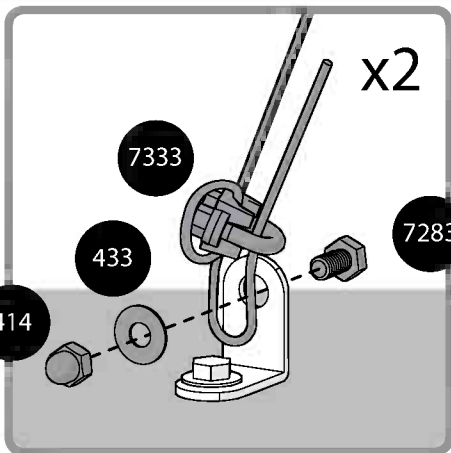

2

OR

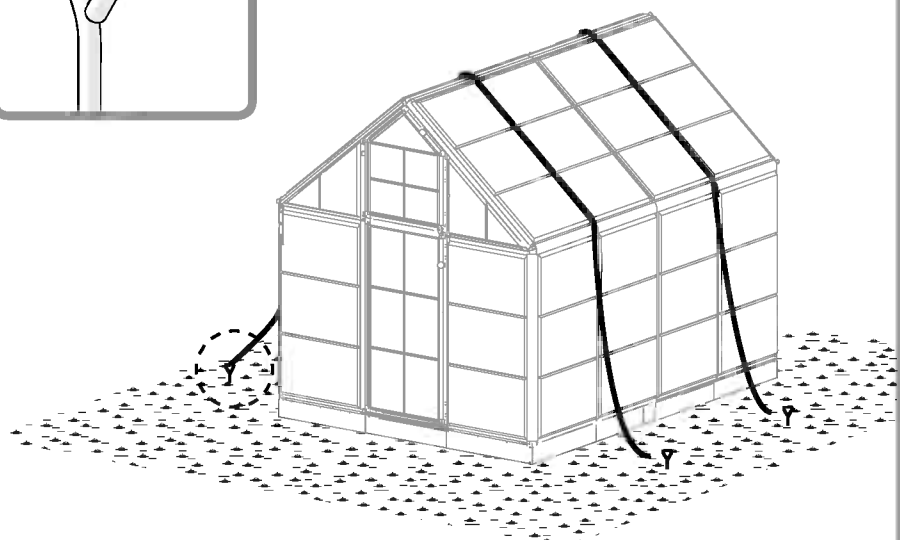
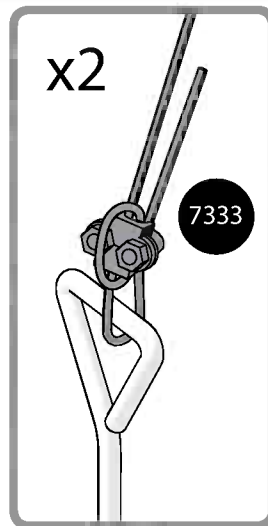

5 **i**

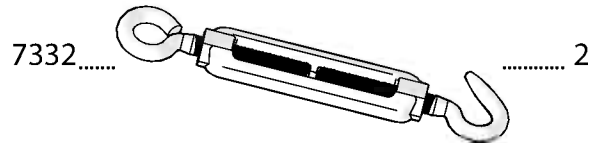
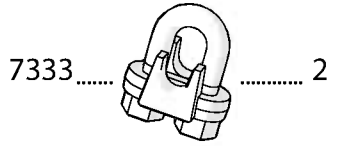

1

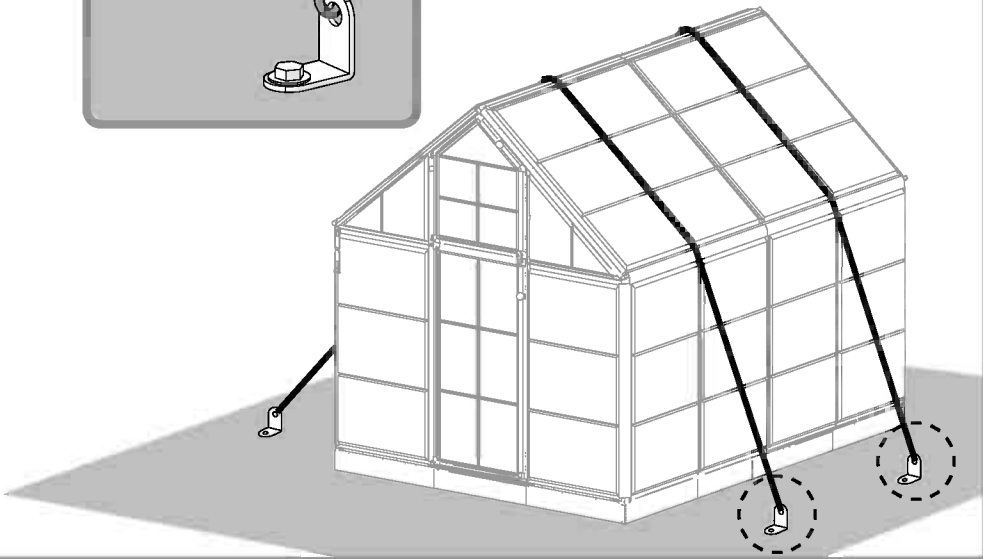
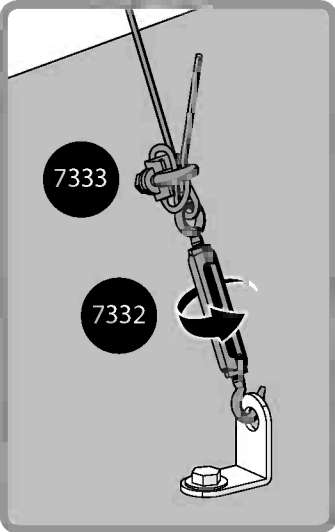

OR

2

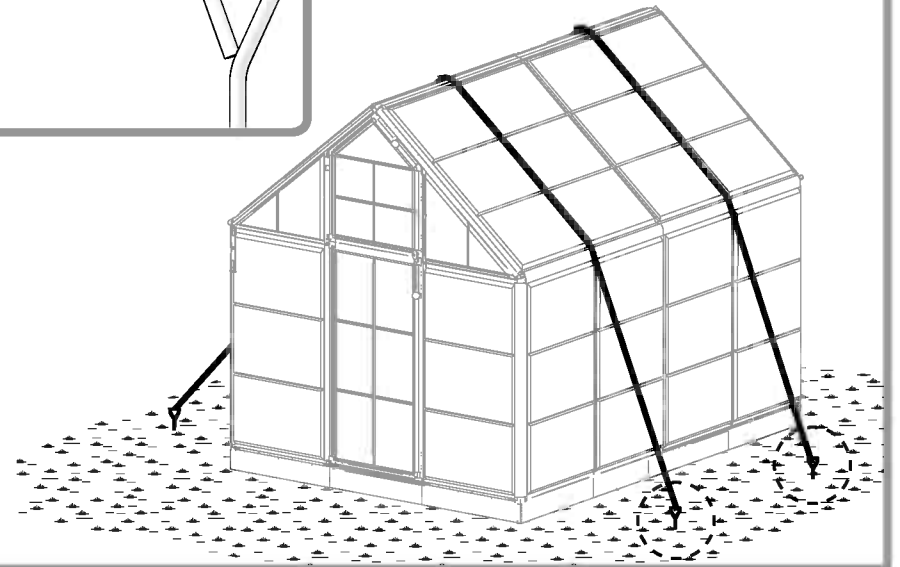
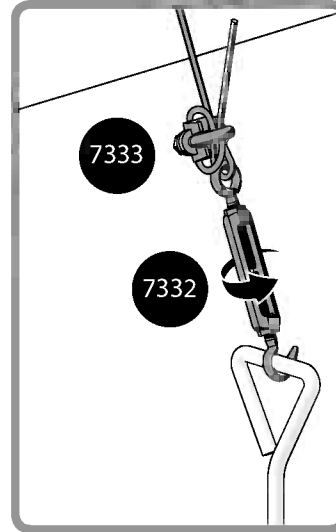

EN

PALRAM - CANOPIA | 2 YEAR LIMITED WARRANTY

Palram Canopia Ltd. (Company number: 512106824) whose registered office is at Teradion Industrial Park, M.P. Misgav 2017400, Israel ("Canopia") warrants that the product will be free from defects in material or workmanship for a period of 2 years from the original date of purchase. • This warranty is valid only if the product is installed, handled, cleaned, and maintained in accordance with Canopia's written specifications. • This warranty does not cover defects resulting from normal wear and tear including, but not limited to: damage caused by use of force, incorrect handling, inappropriate use, negligence, accidents, impact from foreign objects, vandalism, pollutants, alteration, painting, damage resulting from cleaning with incompatible detergents or minor deviations of the product. • This warranty does not apply to damage resulting from "acts of Nature", which includes but is not limited to hail, storm, tornado, hurricane, blizzard, flood, or fire. • Upon submitting proof of purchase and evidence of the claimed product failure, and subject to reporting the failure in writing within 30 days after discovery of the defect, Canopia, at its sole discretion, will replace defective parts of the Product, or refund you a prorated portion of the purchase price on a straight-line depreciated basis for the length of the warranty.

FR

GARANTIE LIMITÉE À 2 ANS DE PALRAM - CANOPIA

Palram Canopia Ltd. (Compagnie n° 512106824) dont le siège social est adressé au Parc Industriel Teradion, M.P. Misgav 2017400, Israël ("Canopia") garantit que le produit est exempt de tout défaut de matériau ou de fabrication pendant une période de 2 ans à compter de la date d'achat initiale. • Cette garantie n'est valable que si le produit est installé, manipulé, nettoyé et entretenu conformément aux spécifications établies par écrit de Canopia. • Cette garantie ne couvre pas les défauts résultant de l'usure normale, y compris, mais sans s'y limiter, les suivants : dommages causés par le forçage du produit, une mauvaise manipulation, une utilisation incorrecte, la négligence, les accidents, l'impact de corps étrangers, le vandalisme, les contaminants, les modifications, l'application de peinture, le nettoyage avec des détergents incompatibles ou les modifications mineures du produit. • Cette garantie ne s'applique pas aux dommages résultant de "catastrophes naturelles", y compris, mais sans s'y limiter, la grêle, les tempêtes, les tornades, les ouragans, les blizzards, les inondations ou les incendies. • Sur présentation de la preuve d'achat du Produit ainsi que de la preuve de la défaillance alléguée, et à condition que vous signaliez la défaillance par écrit dans les 30 jours suivant la découverte du défaut, Canopia remplacera, à sa seule discrétion, les pièces défectueuses du produit ou vous remboursera une partie proportionnelle du prix d'achat sur une base d'amortissement linéaire pour la durée de la garantie.

DE

2 JAHRE BESCHRÄNKTE GARANTIE VON PALRAM - CANOPIA

Palram Canopia Ltd. (Firmennummer: 512106824) mit Sitz in Teradion Industrial Park, M.P. Misgav 2017400, Israel („Canopia“) garantiert, dass das Produkt für einen Zeitraum von 2 Jahren ab dem ursprünglichen Kaufdatum frei von Material- und Verarbeitungsfehlern ist. • Diese Garantie ist nur gültig, wenn das Produkt gemäß den schriftlichen Spezifikationen von Canopia installiert, behandelt, gereinigt und gewartet wird. • Diese Garantie deckt keine Defekte ab, die auf normalen Verschleiß zurückzuführen sind, einschließlich, aber nicht beschränkt auf: Schäden, die durch Gewaltanwendung, falsche Handhabung, unsachgemäßen Gebrauch, Fahrlässigkeit, Unfälle, Einwirkungen von Fremdkörpern, Vandalismus, Schadstoffe, Veränderungen, Anstriche, Schäden, die durch Reinigung mit unverträglichen Reinigungsmitteln entstanden sind, oder geringfügige Abweichungen des Produkts. • Diese Garantie gilt nicht für Schäden, die durch „höhere Gewalt“ entstanden sind, wie z. B. Hagel, Sturm, Tornado, Orkan, Schneesturm, Überschwemmung oder Feuer. • Bei Einreichung des Kaufbelegs und des Nachweises des beanstandeten Produktfehlers und vorbehaltlich der schriftlichen Meldung des Fehlers innerhalb von 30 Tagen nach Entdeckung des Fehlers ersetzt Canopia nach eigenem Ermessen die fehlerhaften Teile des Produkts oder erstattet Ihnen einen anteiligen Teil des Kaufpreises auf linearer Abschreibungsbasis für die Dauer der Garantie.

ES

GARANTÍA LIMITADA DE 2 AÑOS DE PALRAM - CANOPIA

Palram Canopia Ltd. (Número de la compañía: 512106824) cuya oficina registrada se encuentra en Teradion Industrial Park, M.P. Misgav 2017400, Israel ("Canopia") garantiza que el producto estará libre de defectos de material o de fabricación durante un periodo de 2 años a partir de la fecha inicial de compra. • Esta garantía solo es válida si el producto se instala, manipula, limpia y mantiene de acuerdo con las especificaciones por escrito de Canopia. • Esta garantía no cubre los defectos resultantes del desgaste normal, entre lo que se incluye, entre otras cosas, lo siguiente: daños causados al forzar el producto, al manipularlo de forma incorrecta, al emplearlo de forma inapropiada, por negligencia, por accidentes, por impactos de objetos extraños, por vandalismo, por contaminantes, por modificaciones, por haber sido pintado, por la limpieza con detergentes incompatibles o por pequeñas modificaciones del producto. • Esta garantía no se aplica a los daños que resulten de "fenómenos naturales", lo que incluye, pero no se limita, al granizo, las tormentas, los tornados, los huracanes, las ventiscas, las inundaciones o los incendios. • Al presentar el comprobante de compra del producto así como una prueba de la falla que se reclama, y a condición de reportar la falla por escrito dentro de los 30 días siguientes al descubrimiento del defecto, Canopia, a su sola discreción, sustituirá las partes defectuosas del Producto, o le reembolsará una porción prorrateada del precio de compra de acuerdo a una base de depreciación lineal según la duración de la garantía.

SV

BEGRÄNSNINGAR I PALRAM - CANOPIA 2-ÅRS GARANTI

Palram Canopia Ltd. (Bolagsnummer: 512106824) vars registrerade huvudkontor har adressen: Teradion Industrial Park, M.P. Misgav 2017400, Israel ("Canopia") garanterar att produkten är fri från material- och tillverkningsfel under en period av 2 år från det ursprungliga inköpsdatumet. • Garantin gäller endast om produkten installeras, hanteras, rengörs och underhålls i enlighet med Canopias skriftliga specifikationer. • Garantin täcker inte defekter som beror på normalt slitage, inklusive, men inte begränsat till: skador som orsakats av våld, felaktig hantering, olämplig användning, vårdslöshet, olyckor, påverkan från främmande föremål, vandalism, föroreningar, ändring, målning, skador som orsakats av rengöring med inkompatibla rengöringsmedel eller smärre avvikelser av produkten. • Denna garanti gäller inte för skador till följd av "naturkatastrofer", vilket inkluderar men inte är begränsat till hagel, storm, tornado, orkan, snöstorm, översvämning eller brand. • Mot uppvisande av inköpsbevis och bevis för det påstådda produktfelet, och under förutsättning att felet rapporteras skriftligen inom 30 dagar efter upptäckten av felet, kommer Canopia, efter eget gottfinnande, att byta ut defekta delar av produkten eller återbetala dig en proportionell del av inköpspriset på linjär avskrivningsbasis under garantins längd.

NN

PALRAM - CANOPIAS 2 ÅRS BEGRENSEDE GARANTI

Palram Canopia Ltd. (Selskapsnummer: 512106824) med hovedkontor i Teradion Industrial Park, M.P. Misgav 2017400, Israel ("Canopia") garanterer at produktet vil være uten defekter i materiale eller utførelse i en periode på 2 år fra den opprinnelige kjøpsdatoen. • Denne garantien gjelder bare hvis produktet er installert, håndtert, rengjort og vedlikeholdt i henhold til Canopias skriftlige spesifikasjoner. • Denne garantien dekker ikke feil som skyldes normal slitasje, inkludert, men ikke begrenset til: skade forårsaket av bruk av makt, feil håndtering, upassende bruk, uaktsomhet, ulykker, påvirkning fra fremmedlegemer, hærverk, miljøgifter, endring, maling, skade som følge av rengjøring med inkompatible vaskemidler eller mindre avvik i produktet. • Denne garantien gjelder ikke for skader som følge av naturfenomener, inkludert, men ikke begrenset til, hagl, storm, tornado, orkan, snøstorm, flom eller brann. • Ved innlevering av kvittering på kjøp og bevis på den påståtte produktfeilen, og med forbehold om skriftlig rapportering av feilen innen 30 dager etter oppdagelsen av feilen, vil Canopia, etter eget skjønn, erstatte defekte deler av produktet, eller refundere deg en del av kjøpesummen beregnet ved bruk av lineær metode på grunnlag av garantiens varighet.