

HOW TO ASSEMBLE

HARMONY™ 6x8 / 2x2.5

IMPORTANT!

Please read these instructions carefully before starting assembly.
Keep these instructions in a safe place for future reference.

www.canopia.com

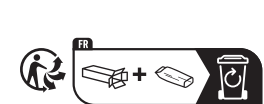

HAVE A CONCERN? WE CAN HELP.

Before returning your purchase:

Please take a look at our
"How to Assemble" video guide.
Scan the QR Code below or go to
canopia.shop/Assemble-GH6

You didn't find what you
were looking for?
We can help at
canopia.shop/support

Still can't find what you
are looking for?
Please see next page for
local customer care.

HABEN SIE BEDENKEN? WIR KÖNNEN HELFEN.

Bevor Sie Ihren Kauf zurücksenden:

Schauen Sie sich bitte unsere
„Videoanleitung Zusammenbau“ an.
Scannen Sie den QR-Code unten
oder besuchen Sie
canopia.shop/Assemble-GH6

Haben Sie nicht gefunden,
wonach Sie gesucht haben?
Unter canopia.shop/support
können wir helfen.

Sie haben noch nicht
gefunden wonach Sie suchen?
Auf der nächsten Seite
finden Sie den Kontakt zu
unserem lokalen Kundendienst.

TIENE ALGUNA INQUIETUD? PODEMOS AYUDARLE.

Antes de retornar su compra:

Por favor mire nuestro video de
montaje "How to Assemble".
Escanee el código QR abajo o
canopia.shop/Assemble-GH6

No encontré lo que
estaba buscando?
Podemos ayudarle en
canopia.shop/support

Aún no encontré lo que buscaba?
Por favor vea en la siguiente
página el Servicio Local al Cliente.

UN SOUCI? UNE QUESTION? NOUS POUVONS VOUS AIDER.

Avant de renvoyer ce produit:

Jetez un coup d'oeil à notre
Vidéo d'Assemblage.
Scannez le code QR ci-dessous
ou rendez vous sur
canopia.shop/Assemble-GH6

Vous n'avez pas trouvé
ce que vous cherchez ?
Nous pouvons vous aider sur
canopia.shop/support

Insatisfait/e ou sans réponse ?
Merci de contacter notre Service
Client local ci-dessous.

HAI PREOCCUPAZIONI? POSSIAMO AIUTARE.

Prima di restituire il tuo acquisto:

Si prega di dare un'occhiata al nostro
Videoguida "Come assemblare".
Scansiona il QR Code qui sotto o vai su
canopia.shop/Assemble-GH6

Non hai trovato quello che volevi
cercavano?
possiamo aiutare a
canopia.shop/support

Non riesco ancora a trovare quello che
tustai cercando?
Si prega di vedere la pagina successiva
perassistenza clienti locale.



UK • IE	FR • BE • IT • NL • PT • ES
01302-380775	+33-169-791-094
DE • AT • LUX • LICH	US
+49-180-522-8778	877-627-8476
IL	CA
04-848-6800	905-5646007
AUS	AUS - Greenhouses only
1800-955-855	03-9544-6-999
ZA	NZ
011-397-7771	0800 800 880
SZ	GLOBAL CONTACT (Rest of World)
062-287-33-77	+972-4-848-6816

WE ARE
HERE TO
HELP

canopia.com/contact-us



SCAN ME

CR • SL
0599-37-057 info@ms-viscom.com
DK
07-575 42 70 post@nshnordic.com
CH • HU • SK
0493-523-523 servis@garland.cz
PL
Infolinia: 801-011-929 22-349-93-36 kontakt@ogrodosfera.pl
CY
0224-971-13 alpaco@alpacodomica.com www.alpacodomica.com

BASE DIMENSIONS

MODEL	6x8 / 2x2.5	
WIDTH	A	185 cm / 6'1"
LENGTH	B	246 cm / 8'1"
MIN. SPACE	C	5 cm / 2"

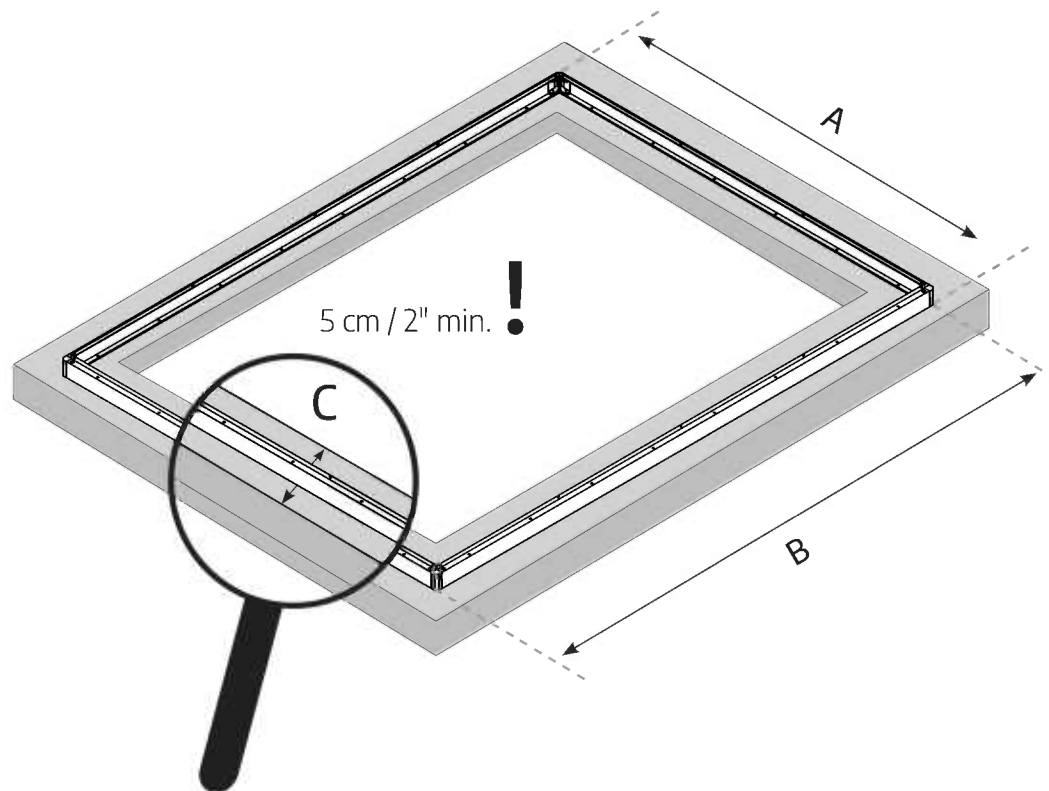

TOOLS & EQUIPMENT

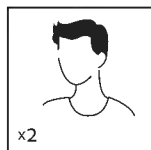

2 people needed



Work gloves

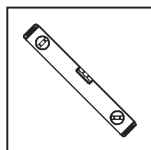

Spirit Level

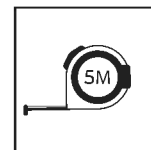

Tape measure

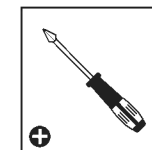

Phillips head
Screwdriver

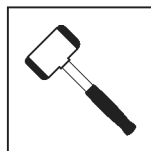

Rubber Mallet

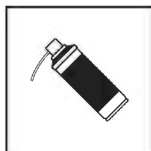

Lubricant Spray



Cordless drill
Phillips head

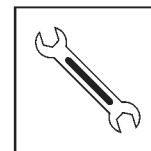

Wrench
10 mm | 3/8"

SITE PREPARATION & FOUNDATION

A - PREPARE THE SITE

The product must be positioned and fixed on a flat level surface.

1 - Clear the site



2 - Level the ground

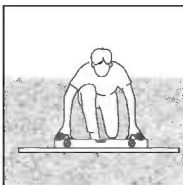

	A	1	2
FR	PRÉPARER LE TERRAIN Le produit doit être positionnée et fixée sur une surface plane	Déblayer le terrain	Niveler le sol
DE	VORBEREITUNG DES UNTERGRUNDES Das Produkt muss auf einem flachen Untergrund aufgestellt und befestigt werden.	Standort säubern	Untergrund ausgleichen und nivellieren
ES	PREPARE EL SITIO El producto debe colocarse y fijarse en una superficie plana y nivelada.	Limpie el sitio	Nivele el terreno
SV	FÖRBEREDA OMRÅDET Produkt måste placeras på en fast och plant underlag.	Rensa området	Platta marken
NN	FORBERED OMRÅDET Produkt må plasseres og festes på et flatt underlag.	Rydd området	Flat ut bakken
FI	VALMISTELE RAKENNUSALUE Pinnan on oltava täysin tasainen ja suora, ja perustan oltava kiinteä.	Raivaa rakennusalue	Tasoita maa
DA	FORBERED OMRÅDET Produkt skal placeres og opføres på en plan flade.	Ryd stedet	Gør jorden jævn
NL	TERREIN VOORBEREIDEN Het grondoppervlak moet perfect vlak en waterpas zijn.	Maak het terrein vrij	Egaliseer de grond
IT	PREPARARE IL SITO Il prodotto deve essere posizionato e fissato su una superficie piana	Sgombrare il sito	Livellare il terreno
SK	PRIPRAVTE SI MIESTO Výrobok musí byť postavený a upevnený na rovnom povrchu.	Vyčistite miesto	Vyrovnajte povrch
SL	PRIPRAVITE LOKACIJO Izdelek mora biti nameščen in pritrjen na ravno in ravno površino.	Očistite lokacijo	Poravnajte tla
ET	VALMISTAGE ETTE MAATÜKK Tootetuleb paigaldada ja kinnitada tasasele pinnale	Puhastage maatükk	Tasandage maapinda
HU	TEREP ELŐKÉSZÍTÉSE A termék építési, egyenes vízszintes és felületen helyezze el.	Tisztítsa meg a területet	Egyengesse vízszintesen a talajt
PL	PRZYGOTUJ MIEJSCE Produkt musi być umieszczona i umocowana na płaskiej i równej powierzchni.	Oczyść miejsce	Wyrównaj podłoże
RU	ПОДГОТОВЬТЕ ПЛОЩАДКУ Продукт нужно расположить и зафиксировать на плоской ровной поверхности.	Очистите площадку	Выровняйте грунт
LAT	SAGATAVOJIET VIETU Produktu jānovieto un jānostiprina uz plakanas gludas virsmas.	Noīriet vietu	Nolīdziniet zemi
CS	PŘIPRAVTE SI MÍSTO Produkt musí být umístěn a upevněn na rovném povrchu	Vyčistěte místo	Vyrovnejte povrch
HR	PRIPREMITE LOKACIJU Proizvod mora biti postavljen i pričvršćen na ravnu površinu.	Očistite površinu	Poravnajte tlo
LIT	PARUOŠKITE VIETĄ Produktą reikia išlygiuoti ir įrengti ant plokščio bei lygaus paviršiaus.	Išvalykite vietą	Išlygiuokite pagrindą
BG	ПОДГОТВЕТЕ МЯСТОТО Продуктът трябва да бъде позициониран и фиксиран върху равна повърхност.	Почистете мястото	Изравнете повърхността
HE	כִּן אֵת הָאֵתָר את המוצר יש להקים על קרקע יציבה ומפולסת בכדי שהוא יתפקד כראוי.	פנה את האתר	פלט את הקרקע

B - CHOOSE YOUR FOUNDATION TYPE

As a foundation, we recommend using three material types :
Concrete / Pressure treated wood / wood deck / Paver blocks

Option 1: Solid foundation

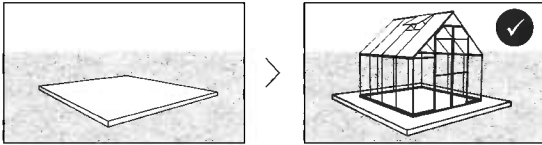

Option 2: Solid frame



Firm ground / grass



ONLY WITH EXTERNAL ANCHORING KIT (SOLD SEPARATELY)



* The size of the product displayed is for illustration purposes only and may not reflect the size of your product.

	B	✓	✓	⚠
FR	<p>CHOISIR VOTRE TYPE DE FONDATION Pour la fondation, nous recommandons d'utiliser trois types de matériaux : Béton / Bois traité sous pression / plancher en bois / Blocs de pavés * La taille du produit affichée ici est uniquement à titre d'illustration et ne reflète pas forcément la taille de votre produit.</p>	Une fondation solide	Un cadre rigide	Terre / pelouse ferme UNIQUEMENT AVEC EXTERNE KIT D'ANCRAGE (VENDU SÉPARÉMENT)
DE	<p>FUNDAMENTWAHL Als Fundament stehen Folgende Materialien zur Auswahl (Empfehlung): Beton / Druckbehandeltes Holz / Holzdeck / Pflastersteine. * Die Größe des abgebildeten Gewächshauses dient nur zur Veranschaulichung und entspricht möglicherweise nicht der Größe Ihres Gewächshauses.</p>	Fester Fundament	Fester Rahmen	Erdboden / Gras NUR MIT EXTERN VERANKERUNGSSSET (SEPARAT ERHÄLTlich)
ES	<p>ELIJA EL TIPO DE CIMENTACIÓN Como cimentación, recomendamos usar tres tipos de materiales: Hormigón / Madera prensada / Piso de madera / Adoquín de hormigón. * El tamaño del invernadero que se muestra tiene un propósito meramente ilustrativo y puede no reflejar el tamaño de su invernadero.</p>	cimentación sólida	Estructura sólida	Tierra firme / césped SOLO CON EXTERNO KIT DE ANCLAJE (SE VENDE POR SEPARADO)
SV	<p>VÄLJ GRUNDTYP Som stiftelse rekommenderar vi tre typer av material: Betong / Tryckbehandlat trä / trägolv / Belägningssten * Växthusets storlek är endast för att illustrera och visar inte rätt storlek på ditt växthus.</p>	solid stiftelse	Solid ram	fast mark / gräs BARA MED EXTERN FÖRANKRINGSSATS (SÄLJS SEPARAT)
NN	<p>VELG FUNDAMENTTYPE Som fundament anbefaler vi tre typer materiell: Betong Trykkbehandlet tre/tredekke Belegningsstein * Drivhusets størrelse er bare for illustrasjon, og viser ikke korrekt størrelse på ditt drivhus.</p>	Solid fundament	Solid ramme	Solid bakke / gress KUN MED EKSTERN FORANKRINGSSETT (SOLGT SEPARAT)
FI	<p>VALITSE RAKENNUSPOHJAN TYYPII Rakennuspohjaksi suosittelme kolmea materiaalityyppiä: Betoni Painekäsitelty puu/puukansi Kiveyelementit * Esillä olevan kasvihuoneen koko on tarkoitettu vain havainnollistamistarkoituksiin eikä se välttämättä vastaa kasvihuoneesi kokoa.</p>	Kiinteä rakennus-pohja	Kiinteä kehys	Kova maa / ruohikko VAIN EXTERNALIN KANSSA ANKKUROINTISARJA (MYDÄÄN ERIKSEEN)
DA	<p>VÆLG DIN FUNDAMENTTYPE Til en fundament anbefaler vi at bruge tre materialetyper: Beton / Trykbehandlet træ / trædæk / Udlægningsblokke * Størrelsen på det viste drivhus er kun til illustration og afspejler muligvis ikke størrelsen på dit drivhus.</p>	Solid fundament	Solid ramme	Fast jord/græs KUN MED EKSTERN FORANKRINGSSÆT (SOLGT SEPARAT)
NL	<p>KIES UW TYPE FUNDERING Als fundering adviseren wij drie materiaalsoorten te gebruiken: Beton Onder druk behandeld hout/houten dek Bestratingsblokken * De grootte van de getoonde broeikas dient enkel ter illustratie en weerspiegelt mogelijk niet de grootte van uw eigen broeikas.</p>	Massieve fundering	Massieve kader	Stevige bodem / gras ALLEEN MET EXTERN VERANKERINGSSSET (APART VERKOCHT)
IT	<p>SCEGLIERE IL TIPO DI FONDAMENTA Come fondamenta consigliamo tre tipi di materiali: Calcestruzzo / Legno pressato / Pavimenti in legno / Calcestruzzo per pavimentazioni. * La dimensione della serra visualizzata è solo a scopo illustrativo e potrebbe non rispecchiare le dimensioni della vostra serra.</p>	Fondamenta solide	telaio solida	Terreno compatto / erba SOLO CON ESTERNO KIT DI ANCORAGGIO (VENDUTO SEPARATAMENTE)
SK	<p>VYBERTE SI TYP PODLOŽENIA Pre základňu odporúčame použiť tri typy materiálov: Betón Tlakové upravené drevo/drevená paluba Dlažobné kocky * Veľkosť zobrazeného skleníka slúži iba na ilustráciu a nemusí odrážať veľkosť vášho skleníka.</p>	Pevná založenie miesta	Masívny rám	Pevná zem / tráva IBA S EXTERNAL KOTVIACA SÚPRAVA (PREDÁVA SA SAMOSTATNE)

C - ANCHOR TO FOUNDATION

① - On a solid foundation / frame

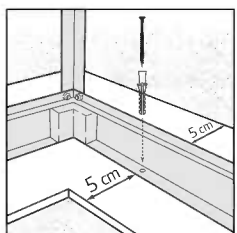
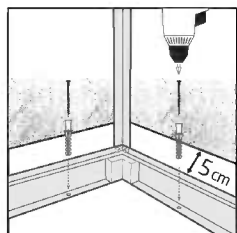

Secure the product to the foundation of your choice using suitable screws & plugs or masonry anchors (not supplied).

Make sure you have at least 5 cm / 2" between the product base and the edges of your foundation - **on all sides**.

* Please consult with an expert regarding which fasteners are suitable for other surface types.

	C	①	*
FR	ANCORAGE A LA FONDATION	Sur une fondation solide / cadre Fixez le produit à la fondation de votre choix, à l'aide de vis et de chevilles appropriées ou d'ancrages en maçonnerie (non fournis). Assurez-vous qu'il y a au moins 5 cm entre la base du produit et le périmètre de votre fondation - de tous les côtés .	Demandez à un expert quels éléments de fixation conviennent à un autre type de surface.
DE	BEFESTIGUNG AM FUNDAMENT	Befestigen Sie das Produkt auf einem festen Fundament / Rahmen Mit geeigneten Dübeln und Schrauben oder Mauerwerksankern, je nach gewähltem Fundamenttyp (nicht mitgeliefert). Stellen Sie sicher, dass zwischen der Basis des Produkts und den Kanten Ihres Fundaments auf allen Seiten mindestens 5 cm Abstand sind.	Bitte fragen Sie einen Experten, welche Befestigungsmittel für andere Untergründe geeignet sind.
ES	ANCLAJE A LOS CIMIENTOS	Sobre una cimentación sólida / estructura Asegure el producto a los cimientos de su elección, usando tornillos y tacos adecuados o anclajes de mampostería (no incluidos). Asegúrese de tener al menos 5 cm 2" entre la base del producto y el perímetro de su cimiento - en todos los lados .	Pregunte a un experto qué elementos de fijación son adecuados para otro tipo superficie.
SV	FEST FÖR STIFTELSE	På en solid stiftelse / ram På en solid bas, säkra produkten till den grund du valt med lämpliga skruvar, pluggar eller väggfästen (ingår ej). Se till att du har minst 5 cm 2" mellan produktens bas och kanterna på fundamente - på alla sidor .	Rådgör med en expert angående vilka fästelement som är lämpliga för trädäck.
NN	FEST TIL FUNDAMENT	På en solid fundament / ramme Sikrer du produktet til fundamentet du har valgt med passende skruer, pluggar eller murfester (ikke inkludert). Forsikre deg om at du har minst 5 cm 2" mellom bunnen av produktet og kantene på fundamentet ditt - på alle sider .	Spør en ekspert hvilke festemidler som er egnet for andre overflater.
FI	RAKENUSSPOHJAN ANKKURI	Kiinteälle rakennuspohjalle / kehykseen Mikäli tuote rakennetaan kiinteälle rakennuspohjalle, kiinnitä tuote valitsemaasi rakennuspohjaan sopivilla ruuveilla & tapeilla tai muurausankkureilla (ei sisälly toimitukseen). Varmista, että sinulla on vähintään 5 cm 2" tilaa tuotteen alustan ja perustuksen reunojen välillä - kaikilla puolilla .	Kysy asiantuntijalta, mitkä kiinnikkeet sopivat puulevyille.
DA	FASTGØRELSE TIL FUNDAMENTET	På et solidt underlag / ramme Skal du fastgøre produktet til det fundament, du vælger, ved hjælp af passende skruer & stik eller murankre (medfølger ikke). Skal du sørge for at have mindst 5 cm 2" mellem produktrammen og kanterne på dit fundament - på alle sider .	Spørg en ekspert, hvilke fastgørelseselementer der egner sig til andre overflader.
NL	VERANKERING AAN FUNDERING	Op een stevige fundering / kader Zet het product op een stevige basis vast op de fundering van uw keuze, met geschikte schroeven & pluggen of metselwerkankers (niet meegeleverd). Zorg ervoor dat u minstens 5 cm hebt tussen de basis van het product en de randen van uw fundering - langs alle kanten .	Vraag een deskundige welke bevestigingsmiddelen geschikt zijn voor andere ondergronden.
IT	ANCORAGGIO ALLE FONDAMENTA	Su fondamenta solida / telaio Fissare il prodotto delle fondamenta di vostra scelta, utilizzando viti e tasselli adeguati o ancoraggi in muratura (non forniti). Assicuratevi di avere almeno 5 cm tra la base del prodotto e i bordi del tuo fondotinta - su tutti i lati .	Chiedete a un esperto quali elementi di fissaggio sono adatti ad altre superfici.
SK	UPEVNENIE PODLOŽENIA	Na pevnom založení miesta / ráme sa uistite Produkt k podloženiu podľa vášho výberu pomocou vhodných skrutiek a hmoždínok alebo murovacích kotiev (nedodané). Uistite sa, že máte najmenej 5 cm 2" medzi základňou výrobku a okrajmi podkladu - na všetkých stranách .	Poradte sa s odborníkom o tom, ktoré upevňovacie prvky sú vhodné pre iné typy povrchov.

SAFETY ADVICE

- It is of utmost importance to assemble all of the parts according to the directions. Do not skip any steps.
 - Always wear work gloves during panel sliding.
 - Always wear shoes and safety goggles when working with extruded aluminium.
 - If using a step ladder or power tools make sure that you follow the manufacturer's safety advice.
 - Do not touch overhead power cables with the aluminium profiles.
 - Do not attempt to assemble the product in windy or wet conditions.
 - Do not climb or stand on the roof.
 - Dispose of all plastic bags. Keep them out of reach of small children.
 - Keep children away from the assembly area.
 - Do not lean against or push the products during construction.
 - Do not position your product in an area exposed to excessive winds.
 - Do not attempt to assemble this product if you are tired, have taken drugs or alcohol or if you are prone to dizzy spells.
 - Hot items such as recently used grills, blowtorches etc. must not be stored in the product.
 - Make sure there are no hidden pipes or cables in the ground before anchoring to foundation.
 - This product is designed to be used mainly as a greenhouse.
- ⚠ Make sure to anchor the product directly to a solid foundation to increase the product's stability and wind resistance in areas with severe weather conditions. Make sure that there are no obstructions between the assembly area and the final position of the product. The Canopia Anchoring kit is available for purchase separately.**

CARE & MAINTENANCE

- When your product needs to be cleaned, use a soft cloth and rinse with cold clean water.
- DO NOT use acetone, abrasive cleaners or other special detergents to clean the panels.
- Clean the product once assembly is complete.

BEFORE ASSEMBLY

- Selecting a site:
 - Choose your site carefully before beginning assembly.
 - Choose a sunny position away from overhanging trees.
 - The product must be positioned and fixed on a flat level surface.
- The product must be secured directly to a solid foundation.
- This is a multi-part assembly best achieved by two people. Allow at least half a day for the assembly process.
- Take all components & parts out of the packages. Sort the parts and check against the content parts list.
- Parts should be laid out close at hand. Keep all small parts (screws etc.) in a bowl so they do not get lost.
- Please note multi-sided profiles are used in this product. As a result some holes in the profiles are not used during assembly.
- Please review entire instructions before starting. Carry out the assembly steps in exact order.
- Please consult your local authorities if any permits are required prior to constructing the product.
- Please ensure you have sufficient side space for inserting the roof panels during the assembly process.

IMPORTANT!

- **Firmly connect the product to a level surface immediately after completion of the assembly.**
- **Anchoring this product to the ground is essential to its stability and rigidity. It is required to complete this stage in order for your warranty to be valid.**
- **During assembly use a soft surface below the parts to avoid scratches and damages.**
- **We recommend checking for restrictions or covenants for building this product in your area.**
In addition we advise to check if you need to submit any forms or if any permit is required prior to building the product.

DURING ASSEMBLY

During assembly, you will encounter different icons for different products. Please see below for more information:



You may use silicone lubricant spray on the frame in order to help you slide the panels into the profiles. Do not spray the panels.

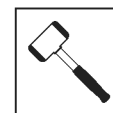

Use a rubber mallet if necessary.

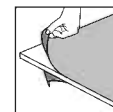

Make sure you remove covering plastic film from both sides of the panel.

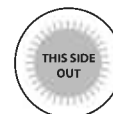

All panels with the stamped words "THIS SIDE OUT" must be facing out to create full UV protection. Remove plastic sticker as panels are locked in place.



This icon indicates that the installer should be inside the product.



This icon indicates that the installer should be outside the product.

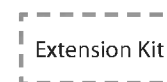

Steps marked with dashed outlines refer to Extensions only. Some of the steps are irrelevant for an assembly of a single product. When assembling a single or an extended product, some parts may be surplus.

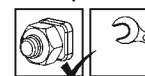
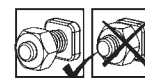

These 2 icons below indicate if screw's tightening is required or not.

Temporary tightening of a few screws may be needed to prevent a profile from sliding out. Tighten all screws once assembly is completed.

CONSEILS DE SECURITE

- Très important ! Veuillez suivre scrupuleusement les instructions de ce manuel et réaliser les étapes dans l'ordre énoncé.
- Nous recommandons vivement le port de gants de protection pendant le montage.
- Portez toujours des chaussures de travail et des lunettes de protection lorsque vous travaillez des pièces en aluminium extrudé.
- Lors de l'utilisation d'une échelle ou d'outils électriques, assurez-vous de bien suivre les consignes de sécurité du fabricant.
- Veillez à ne pas toucher de câbles aériens avec les profilés en aluminium.
- Ne montez pas sur le toit.
- N'essayez pas de monter la produit s'il y a du vent ou s'il fait humide.
- Jetez tous les sacs en plastique en appliquant les règles de sécurité et maintenez-les hors de portée des jeunes enfants.
- Eloignez les enfants de la zone d'assemblage.
- Ne vous appuyez pas contre la produit et ne la poussez pas pendant le montage.
- Ne positionnez pas la produit dans un endroit trop exposé au vent.
- N'essayez pas de monter la produit si vous êtes fatigué, si vous êtes sous l'effet de drogues, de médicaments ou d'alcool ou encore si vous êtes sujet aux vertiges.
- Les objets chauds tels qu'un barbecue, un chalumeau ou autre article ayant été récemment utilisés, ne doivent pas être rangés dans la produit.
- Assurez-vous qu'il n'y a pas de tuyaux ou de câbles cachés dans le sol avant d'ancrer à la fondation.
- Ce produit a été conçu pour être principalement utilisé comme serre.

⚠ Assurez-vous d'ancrer le produit directement sur une surface solide pour augmenter sa stabilité et sa résistance au vent, en particulier dans les zones soumises à des conditions météorologiques extrêmes. Veillez à ce qu'il n'y ait pas d'obstacles entre la zone de montage et la position finale du produit. Le kit d'ancrage Canopia est disponible à l'achat séparément.

ENTRETIEN & MAINTENANCE

- Pour nettoyer votre produit, utilisez un chiffon doux et rincez à l'eau claire et froide.
- NE PAS utiliser d'acétone ni de produits nettoyants ou autres détergents spéciaux pour nettoyer les panneaux clairs.
- Nettoyez le produit une fois le montage termine.

AVANT L'ASSEMBLAGE

- Choisir un endroit :
 - Choisissez votre site avec soin avant de commencer l'assemblage.
 - Choisissez un endroit ensoleillé loin des arbres en saillie.
 - La produit doit être positionnée et fixée sur une surface plane.
- Le produit doit être fixé directement sur une surface solide
- Il s'agit d'un assemblage multi parties qu'il vaut mieux réaliser à deux. Comptez au moins une demi journée pour le processus de montage.
- Retirez tous les composants des paquets. Triez les éléments et vérifiez la liste.
- Les éléments doivent se trouver à portée de main. Gardez tous les petits éléments (vis etc.) dans un bol pour ne pas les perdre.
- Veuillez noter que des coupes multi faces sont utilisées dans cette produit. C'est pourquoi certains trous dans les coupes ne sont pas utilisés pendant le montage.
- Veuillez vérifier toutes les instructions avant de commencer. Procédez aux étapes de montage dans l'ordre exact.
- Veuillez consulter les autorités locales au cas où des permis sont nécessaires pour la construction du produit.
- Veuillez vous assurer que vous disposez d'un espace latéral suffisant pour insérer les panneaux de toit pendant le processus d'assemblage.

IMPORTANT!

- **Connectez du produit fermement à une surface nivelée après l'achèvement de l'assemblage.**
- **L'ancrage du produit au sol entielle à sa stabilité et à sa rigidité, il est de plus nécessaire pour assurer la validité de votre garantie.**
- **Pendant le montage, placez une surface souple sous les pièces pour éviter de les érafler ou de les endommager.**
- **Avant d'assembler ce produit dans votre région, nous vous recommandons de vous renseigner sur les restrictions ou réglementations locales. Nous vous conseillons en outre de vérifier si vous devez soumettre des formulaires ou si un permis est requis avant de monter le produit.**

DURANT L'ASSEMBLAGE

Lors du montage, vous trouverez différentes icônes correspondant à différents produits. Pour de plus amples informations, veuillez vous référer à ce qui suit:



Vous pouvez utiliser un spray de lubrifiant pour silicone afin de vous aider à glisser les panneaux dans les profilés. Ne pulvérisez pas les panneaux.

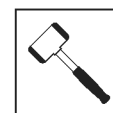

Utilisez un maillet en caoutchouc si nécessaire.

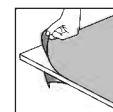

Assurez-vous de retirer le film plastique couvrant des deux côtés du panneau.

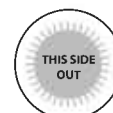

Tous les panneaux estampillés "THIS SIDE OUT" doivent être orientés vers l'extérieur pour assurer une protection UV intégrale. Retirez les stickers en plastique quand les panneaux sont verrouillés et bien en place.



Cette icône indique que l'installateur doit être à l'intérieur du produit.



Cette icône indique que l'installateur doit être en dehors du produit.

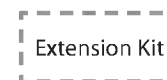

Les étapes marquées en pointillés ne concernent que les extensions. Certaines étapes ne sont pas nécessaires pour l'assemblage d'un produit unique.

Lors de l'assemblage d'un produit unique ou d'une extension, il peut rester des pièces.

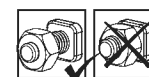

Ces 2 icônes indiquent s'il est nécessaire de serrer les écrous ou non. Il peut être nécessaire de serrer temporairement certaines vis pour empêcher un profilé de se déplacer.

Serrez toutes les vis une fois l'assemblage terminé.

CONSEJOS DE SEGURIDAD

- Es de suma importancia montar todas las partes de acuerdo con las instrucciones. No se salte ningún paso.
 - Recomendamos firmemente el uso de guantes de trabajo durante el montaje.
 - Use siempre zapatos y gafas de seguridad al trabajar con aluminio extruido.
 - Al usar una escalera plegable o herramientas eléctricas asegúrese de que sigue las instrucciones de seguridad de los fabricantes.
 - No toque los cables eléctricos aéreos con los perfiles de aluminio.
 - No intente montar el invernadero en días de viento o días con humedad.
 - No trepe ni se ponga de pie en el tejado.
 - Disponga todas las bolsas plásticas en lugar seguro - guárdelas fuera del alcance de niños.
 - Mantenga a los niños fuera del área de montaje.
 - No se apoye ni empuje el producto durante la construcción.
 - No coloque su producto en un área expuesta al viento excesivo.
 - No intente montar este producto si usted está cansado, ha tomado drogas o alcohol o si usted es propenso a ataques de mareo.
 - Artículos calientes recientemente usados tales como parrillas, sopletes etc. no deben ser almacenados en el producto.
 - Asegúrese de que no hay tuberías o cables ocultos en el suelo antes de anclar a los cimientos.
 - Este producto fue diseñado para ser utilizado principalmente como un Cobertizo de jardín.
- ⚠ Asegúrese de anclar el producto directamente a una base sólida para aumentar su estabilidad y resistencia al viento, especialmente en áreas con condiciones climáticas severas. Asegúrese de que no haya obstáculos entre la zona de montaje y la posición final del producto. El kit de anclaje de Canopia puede adquirirse por separado.**

CUIDADOS & MANTENIMIENTO

- Para limpiar el producto, use un trapo suave y enjuague con agua limpia y fría.
- NO use acetona, limpiadores abrasivos u otros detergentes especiales para limpiar los paneles transparentes.
- Limpie el producto una vez terminado el montaje.

ANTES DEL MONTAJE

- Seleccionar un lugar:
 - Elija su sitio cuidadosamente antes del ensamblaje inicial.
 - El producto debe colocarse y fijarse en una superficie plana y nivelada.
 - escoja una ubicación soleada y apartada de árboles que la cubran.
- El producto debe fijarse directamente a una superficie sólida.
- Este montaje consta de varias partes y sería óptimo que lo realizaran dos personas. El proceso de montaje llevará alrededor de medio día.
- Extraiga todas las piezas de componentes de sus embalajes. Ordene las piezas y compruebe que están todas usando la lista de contenidos.
- Las piezas deberían colocarse cerca y tenerlas a mano. Ponga las piezas pequeñas (p. ej. tornillos) en un bol para no perderlas.
- Por favor, tenga en cuenta que este producto incluye perfiles con múltiples superficies. Como resultado, algunos de los agujeros de los perfiles no se utilizan durante el montaje.
- Por favor, revise todas las instrucciones antes de empezar. Siga los pasos del montaje en el orden exacto.
- Consulte las limitaciones, requisitos, permisos y a las autoridades locales para la construcción de este cobertizo de jardín.
- Por favor asegúrese de que tiene suficiente espacio lateral para la inserción de los paneles del techo durante el proceso de montaje.

¡IMPORTANTE!

- **Conecte firmemente el producto a una superficie nivelada inmediatamente después de terminar el montaje.**
- **Anclar este producto al suelo es esencial para su estabilidad y rigidez. Es necesario completar esta fase para que su garantía sea válida.**
- **Durante el montaje, ponga algo suave por debajo de las piezas, para evitar que se rayen o estropeen.**
- **Recomendamos comprobar las restricciones o convenios para la construcción de este producto en su área.** Además, aconsejamos comprobar si necesita presentar algún formulario o si se requiere algún permiso antes de construir el producto.

DURANTE EL MONTAJE

Durante el montaje, se encontrará con diferentes iconos. Para obtener más información, consulte lo siguiente:



Puede utilizar espray lubricante de silicona para facilitar el deslizamiento de los paneles en los contornos. No ponga espray en los paneles.

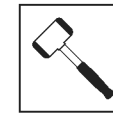

Use un martillo de goma si quiere falta.

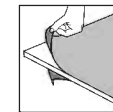

Asegúrese de quitar la película plástica que cubre ambos lados del panel.

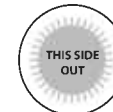

Todos los paneles que tengan estampado LADO EXTERIOR (THIS SIDE OUT) deben mirar hacia fuera para ofrecer una protección UV completa. Quite la pegatina de plástico una vez los paneles se enganchen en su sitio.



Este ícono indica que el instalador debe estar dentro del producto.



Este ícono indica que el instalador debe estar fuera del producto.



Los pasos marcados con líneas discontinuas se refieren únicamente a las extensiones.

Algunos de los pasos son innecesarios para el montaje de un solo producto.

Durante el montaje de un producto individual o de una extensión, pueden sobrar algunas piezas.

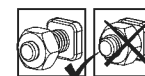

Los siguientes 2 íconos le indicarán si el ajuste de los tornillos es necesario o no.

en algún paso puede ser necesario apretar de forma temporal algunos tornillos para evitar que se caiga un perfil.

Apriete todos los tornillos una vez esté completado el montaje.



IMPORTANT ASSEMBLY STEPS

When encountering this information icon during assembly, please refer the relevant assembly step for important additional comments.

- Step 6:** Determines the front side of the greenhouse.
- Steps 10, 16, 19:** The oval hole in the crossbars #256 should always be assembled to the base of the greenhouse.
- Steps 12-13:** In order to insert profile #8378 in between two #7311 & #7310 profiles, please apply silicone lubricant spray.
- Door Assembly:**
Can be installed as a left hand door or right hand door to your decision. These instructions show a right hand door assembly.
- Step 14:** Determines door direction door post #7311 is where door hinges will be located.
- Steps 39+40:** **Window Assembly:**
Decide on the window's location before assembly. Window can be installed in one of the indicated options. Once the window location is chosen, please turn part #7316 into the correct position accordingly.
- Step 55:** In case the window is not closed properly, please go to **Step 42**, release the screws, adjust the profile and tighten the screw.
- Steps 57-65:** Determines door direction door post #7311 is where door hinges will be located (**Step 14**).
Door assembly should be done according to this decision.



PRINCIPALES ÉTAPES D'ASSEMBLAGE

Lorsque vous rencontrez cette icône d'information pendant l'assemblage, veuillez vous référer à l'étape d'assemblage correspondante pour d'autres commentaires importants.

- Étape 6:** Identifier le côté avant de la serre.
- Étapes 10, 16, 19:** Le trou ovale dans les barres fixes #256 doit toujours être monté à la base de la serre.
- Étapes 12-13:** Afin d'insérer le profil #8378 entre les profils #7311 et #7310, veuillez appliquer un lubrifiant à base de silicone.
- Assemblage de la porte:**
La porte peut être installée à gauche ou à droite, selon votre choix. Ces instructions montrent une installation de porte à droite.
- Étape 14:** Déterminer la direction de la porte. Le montant de la porte #7311 est l'endroit où les charnières de la porte seront installées.
- Étapes 39+40:** **Assemblage de la fenêtre**
Choisissez l'emplacement de la fenêtre avant le montage. La fenêtre peut être assemblée dans l'une des options indiquées. Une fois l'emplacement de la fenêtre choisi, veuillez tourner la pièce #7316 dans la bonne position en conséquence.
- Étape 55:** Si la fenêtre n'est pas correctement fermée, veuillez passer à l'**étape 42**, desserrer les vis, ajuster le profil et ensuite serrer les vis.
- Étapes 57-65:** Déterminer la direction de la porte. Le montant de la porte #7311 est l'endroit où les charnières de la porte seront installées (**Étape 14**).
L'installation de la porte doit être effectuée conformément à cette décision.



PASOS DE MONTAJE IMPORTANTES



Al encontrar este icono de información durante el montaje, consulte el paso de montaje correspondiente para obtener importantes comentarios adicionales.

- Paso 6:** Determina el lado frontal del invernadero.
- Pasos 10, 16, 19:** El agujero ovalado en las barras transversales. #256 siempre debe ser montado en la base del invernadero.
- Pasos 12-13:** Para introducir el perfil #8378 entre los dos perfiles #7311 & #7310, por favor, aplique silicona paralubricarlo.
Montaje de la puertala puerta.
- Montaje de la puerta:**
La puerta puede ser instalada a la izquierda o a la derecha segim su decision. Estas instrucciones muestran montaje de una puerta a derecha.
- Paso 14:** Determina la direccion de la puerta al lado #7311 es donde se encuentran las bisagras de la puerta.
- Pasos 39+40:** **Montaje de la ventana:**
Decida la ubicacion de la ventana antes del montaje.
La ventana puede instalarse en una de las opciones indicadas.
Una vez que se elija la ubicacion de la ventana, por favor, gire la pieza #7316 en la posicion correcta en el mismo modo.
- Paso 55:** En el caso de que la ventana no cierre adecuadamente, por favor, extraiga los tornillos, **Paso 42** ajuste el perfil y apriete los tornillos.
- Pasos 56-57:** Determina la direccion de la puerta al lado #7311 es donde se encuentran las bisagras de la puerta (**Paso 14**).
Montaje de la puerta se debe hacer de acuerdo con esta decision.

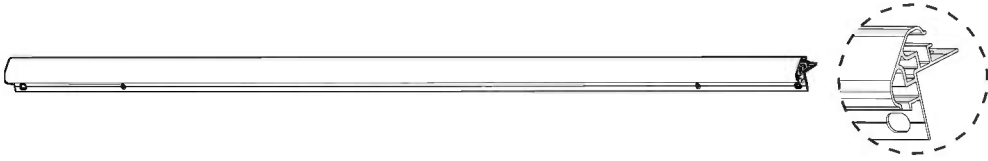
Contents

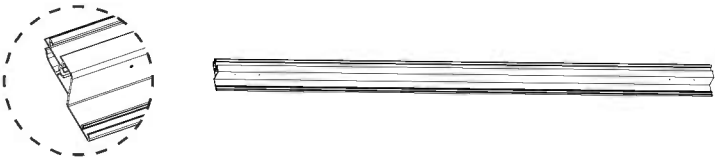
Item		Qty.
996		4



Item		Qty.
7309		4

983		1
993		14

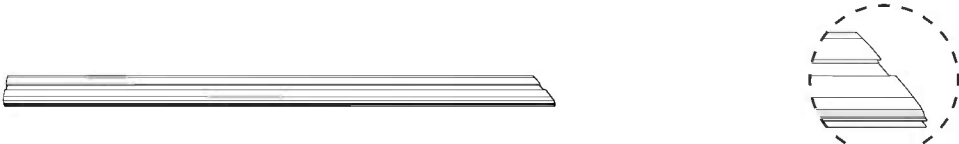
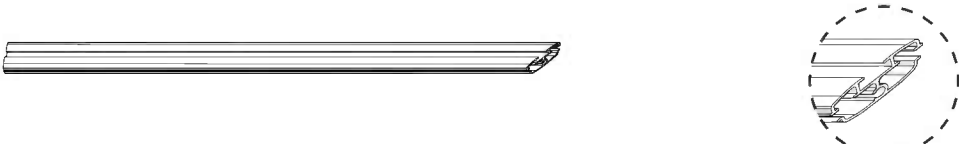
992		2
-----	---	---

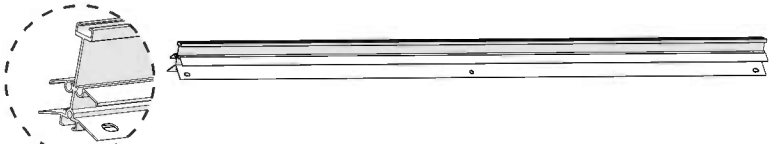
7312		1
7313		1

977		2
-----	---	---

7311		2
7310		2

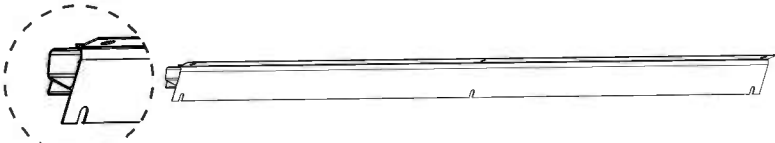
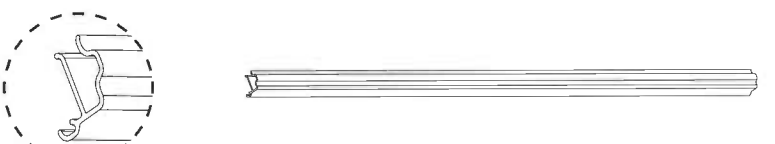
976		4
981		8

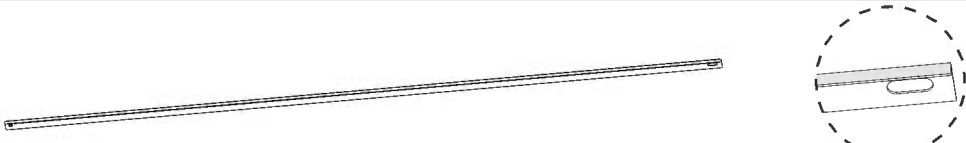
256		8
-----	--	---

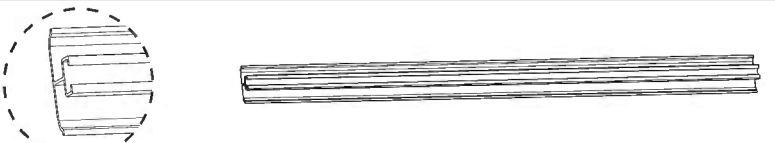
999		5
-----	---	---

Contents

Item	Qty.
984 	2

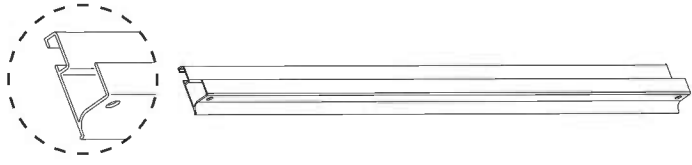
991 	1
---	---

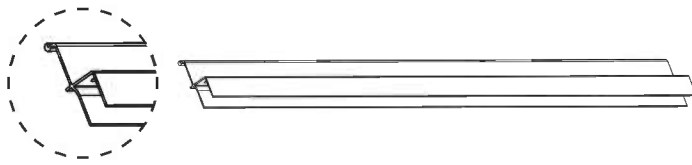
989 	1
---	---

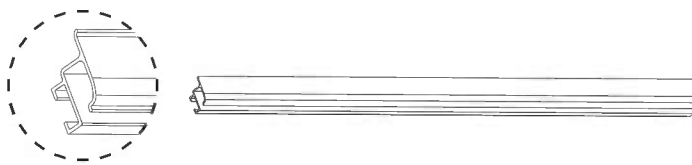
990 	1
--	---

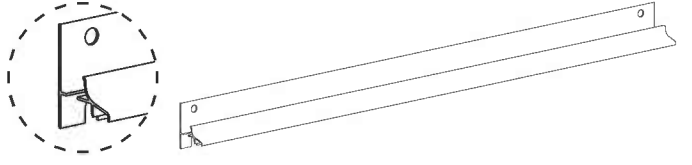
986 	1
---	---

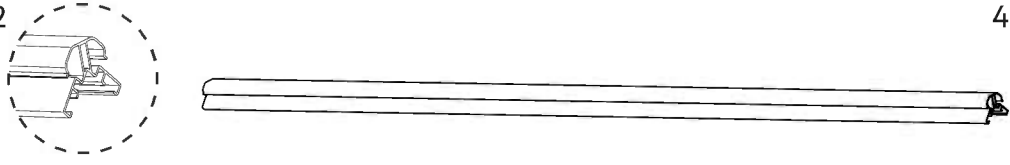
9802 	4
---	---

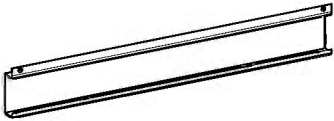
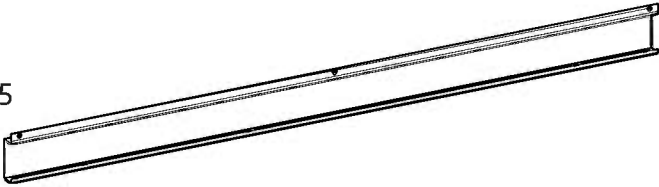
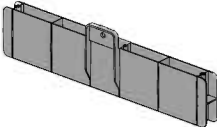
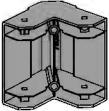
Item	Qty.
1194 	2
1195 	6
8447 	4
7602 	4

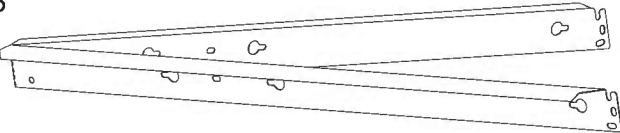
955 	1
---	---

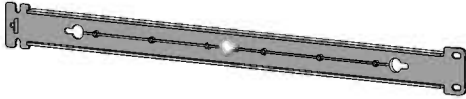
8549 	2
--	---

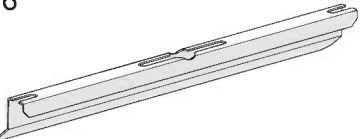
7316 	1
--	---

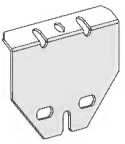
Item	Qty.
08 	2

8710 	3
--	---

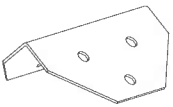
07 	1
--	---

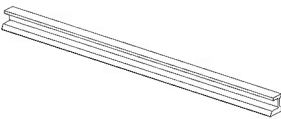
8378 	4
---	---

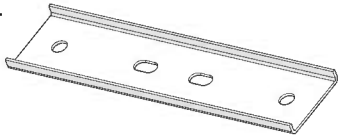
7314 	2
--	---

956 	1
---	---

Contents



Item	Qty.
7011	20
7010	2
567	2
553	1
570	1
559	2
560	2

Item	Qty.
3017	2
3016	1

Item	Qty.
318	15 (+1)
7009	2 (+1)
329	6
292	2
344 L	2
344 R	2

Item	Qty.
343	2
328	19 (+8)
8797	1
8798	1
8801	1
8799	1
8800	1

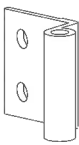
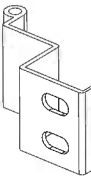
Contents

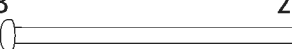
Item	Qty.
464 	4
462 	2
465 	8 (+1)
422 	8 (+1)
463 	2

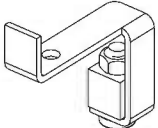
4037 	1
--	---

411 	133 (+6)
---	----------

412 	130 (+9)
---	----------

4008 	10 (+1)
--	---------

4045 	16 (+2)
--	---------

7442 	52 (+3)
--	---------

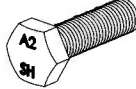

4043 	6 (+1)
--	--------

410 	1
---	---

4044 	2
--	---

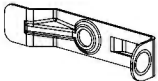
466 	2
---	---

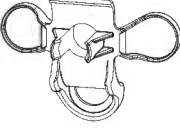
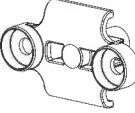
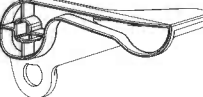
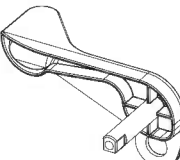
9953 	2
---	---

Item	Qty.
7086 	1
7085 	1
7084 	1
7083 	1
7088  M4 x 50 mm	1
423 	1

1

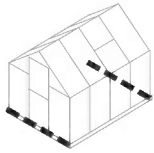

1194	2	8447	2	7442	24
1195	2	7602	4			

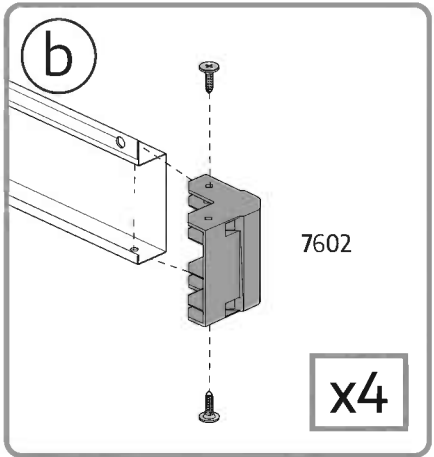
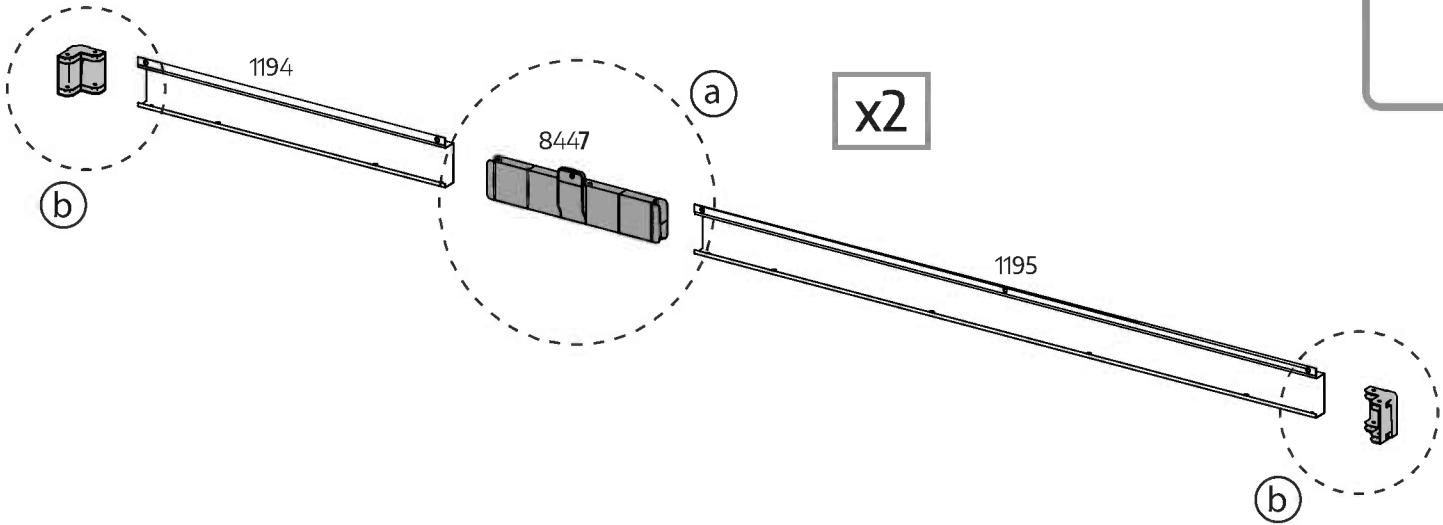
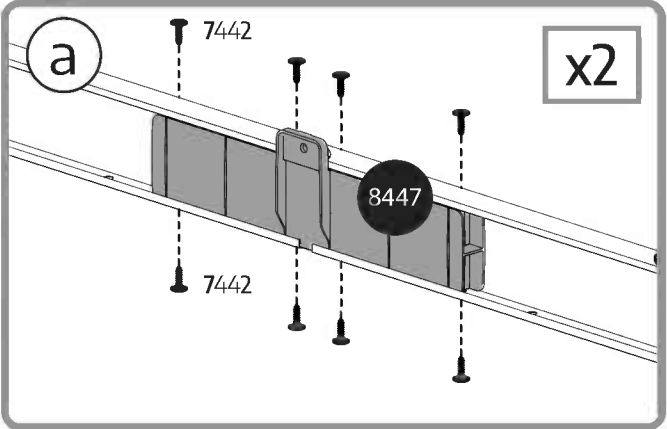
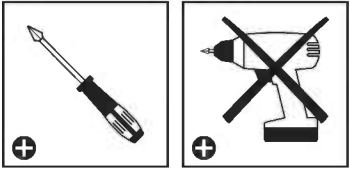

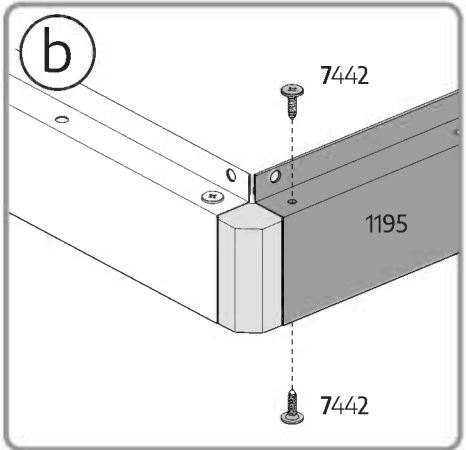
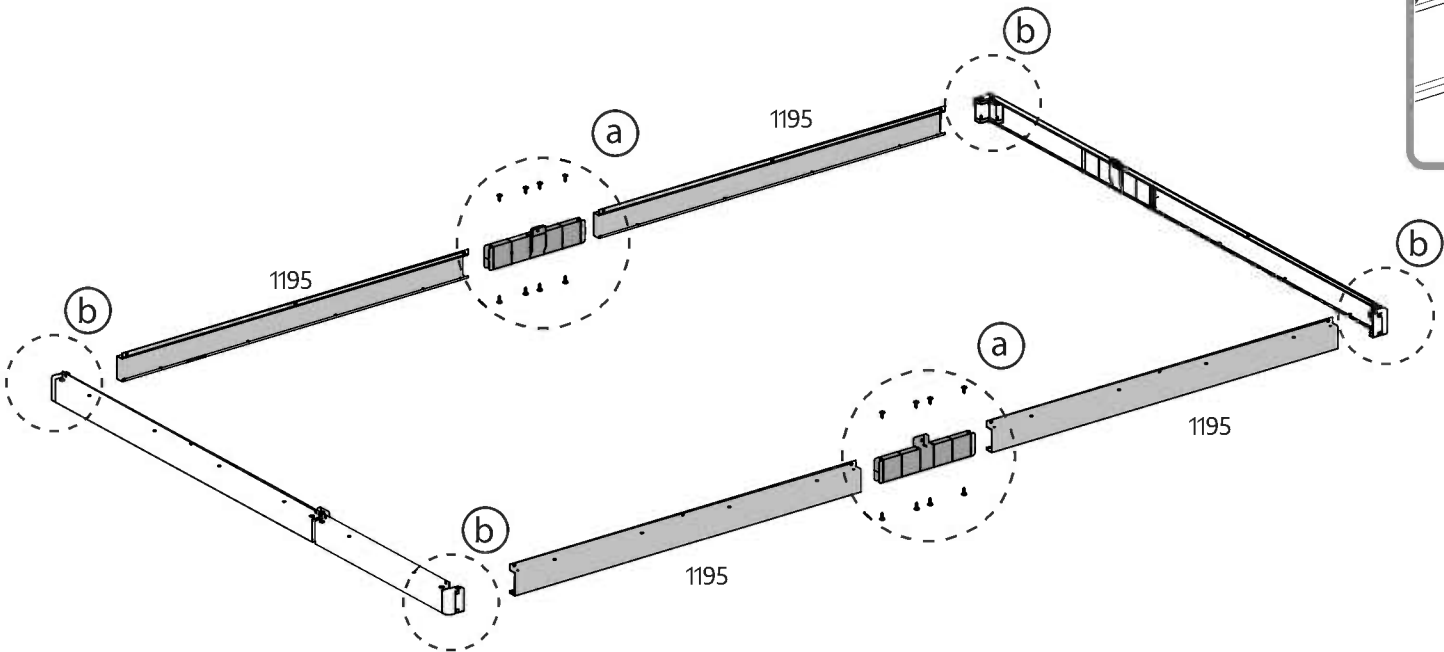
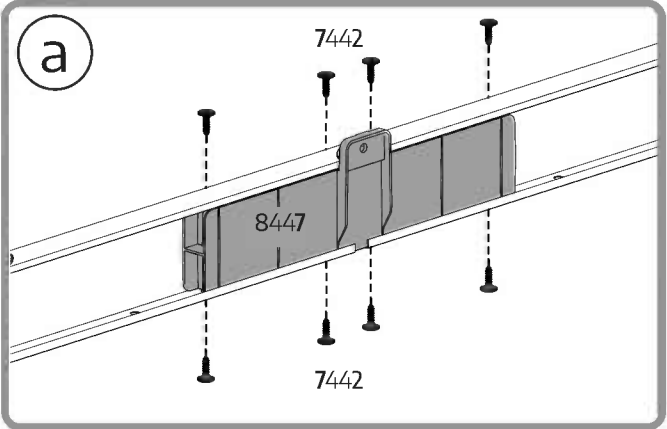
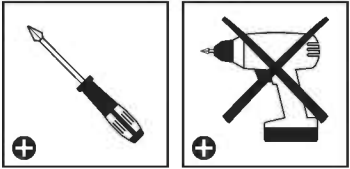
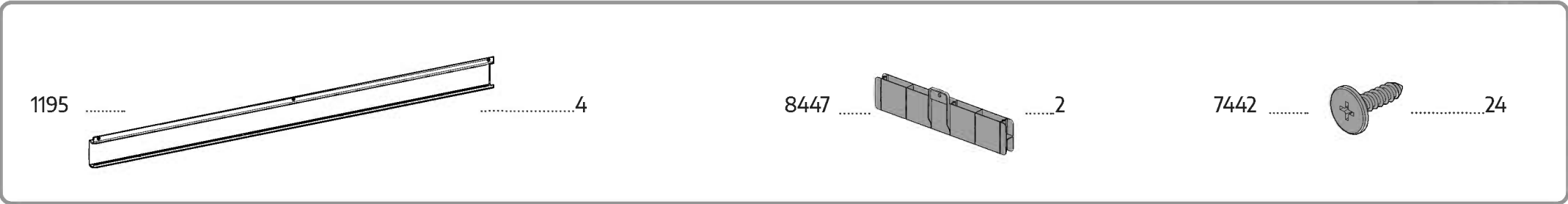

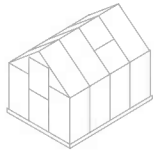

328 19

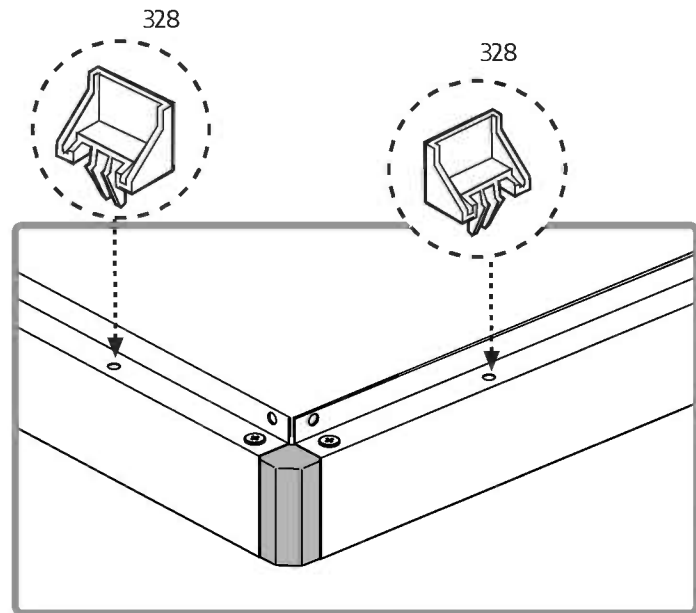
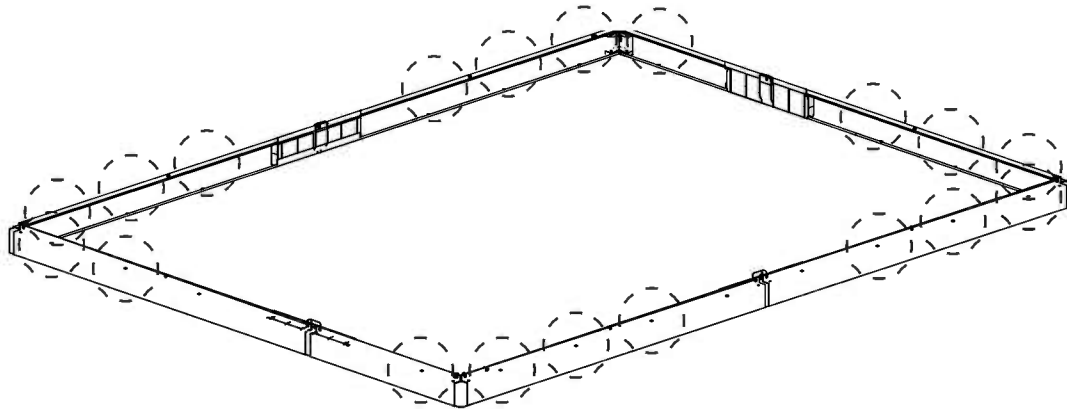
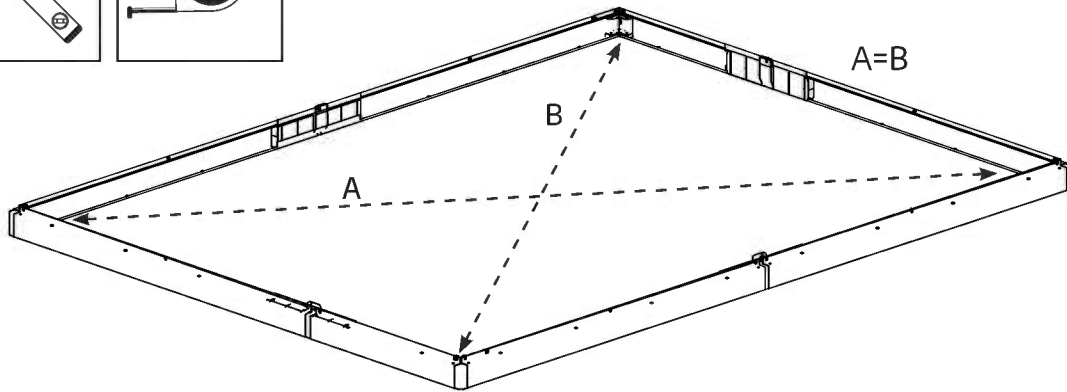
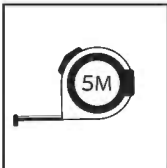
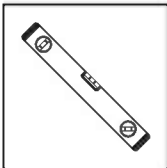
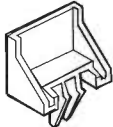

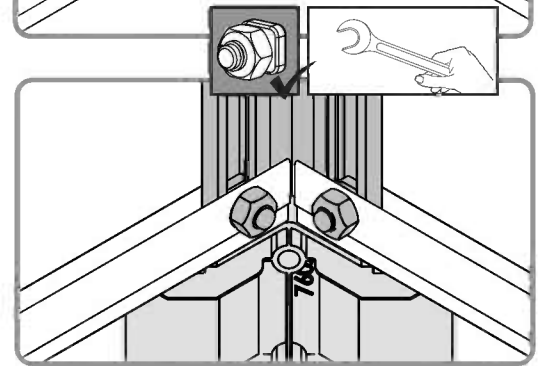
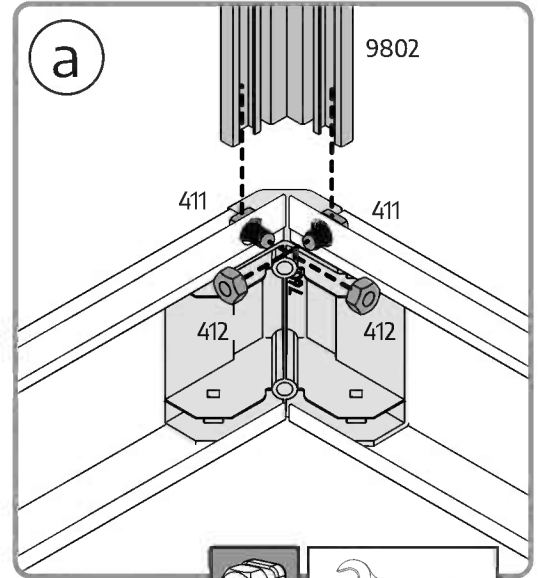
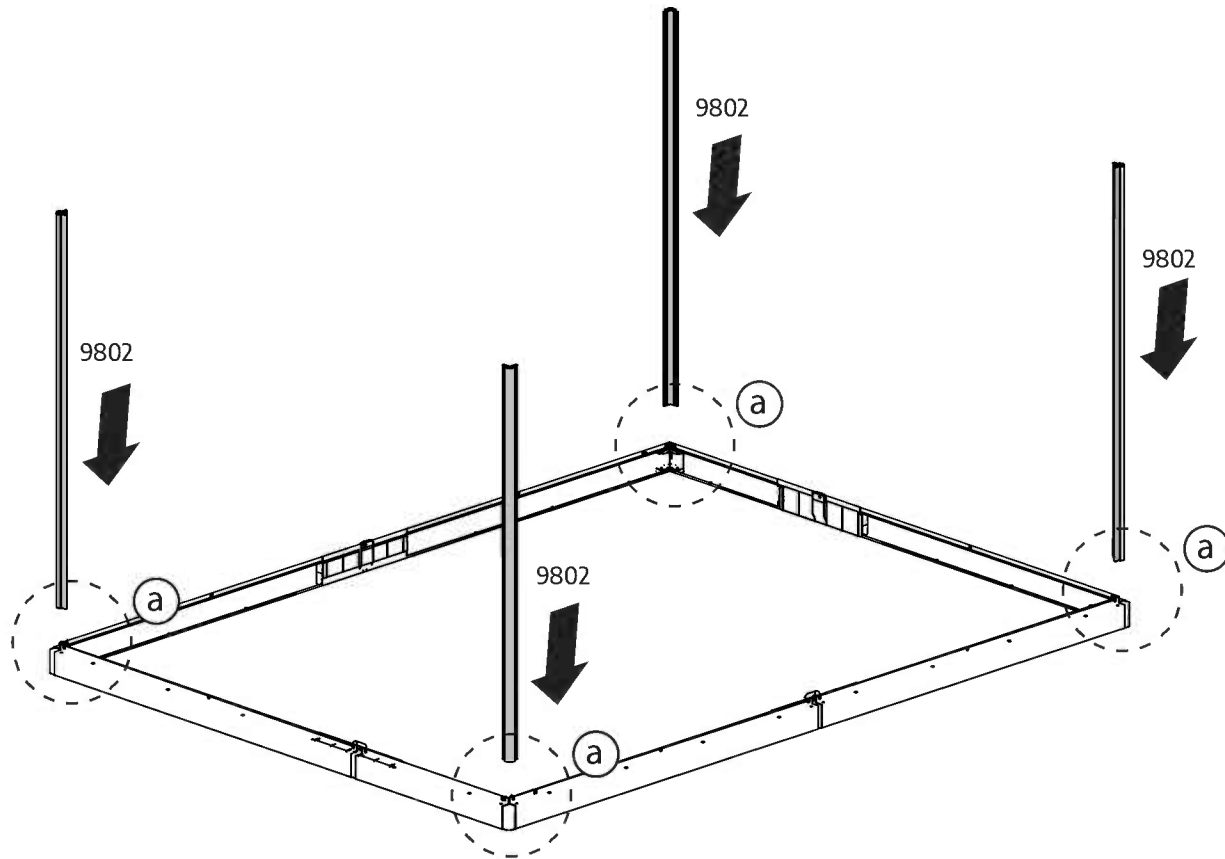
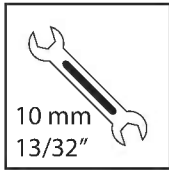
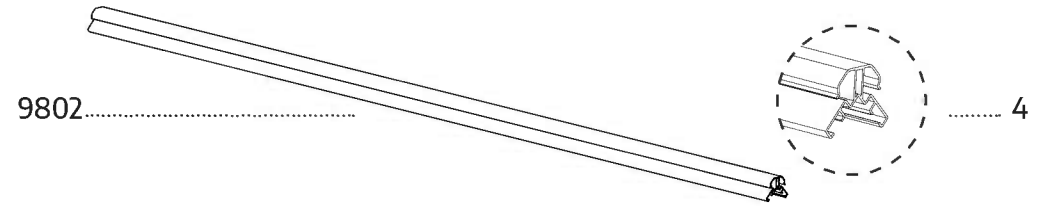
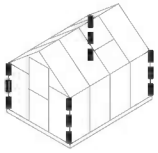

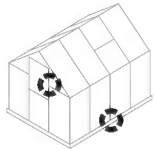

411 10

412 10

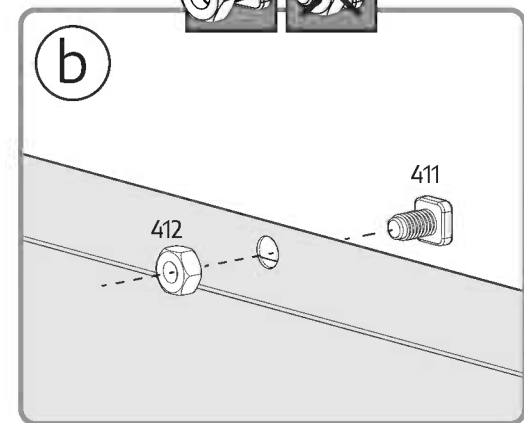
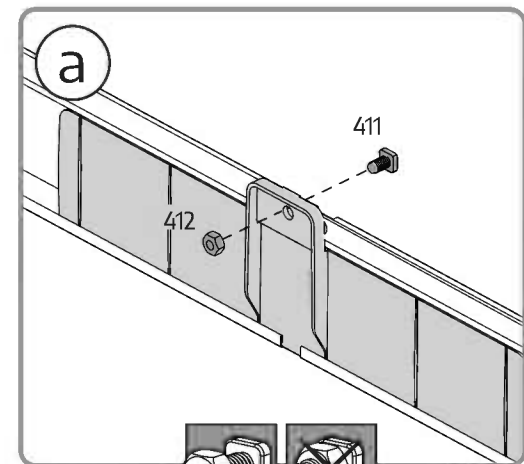
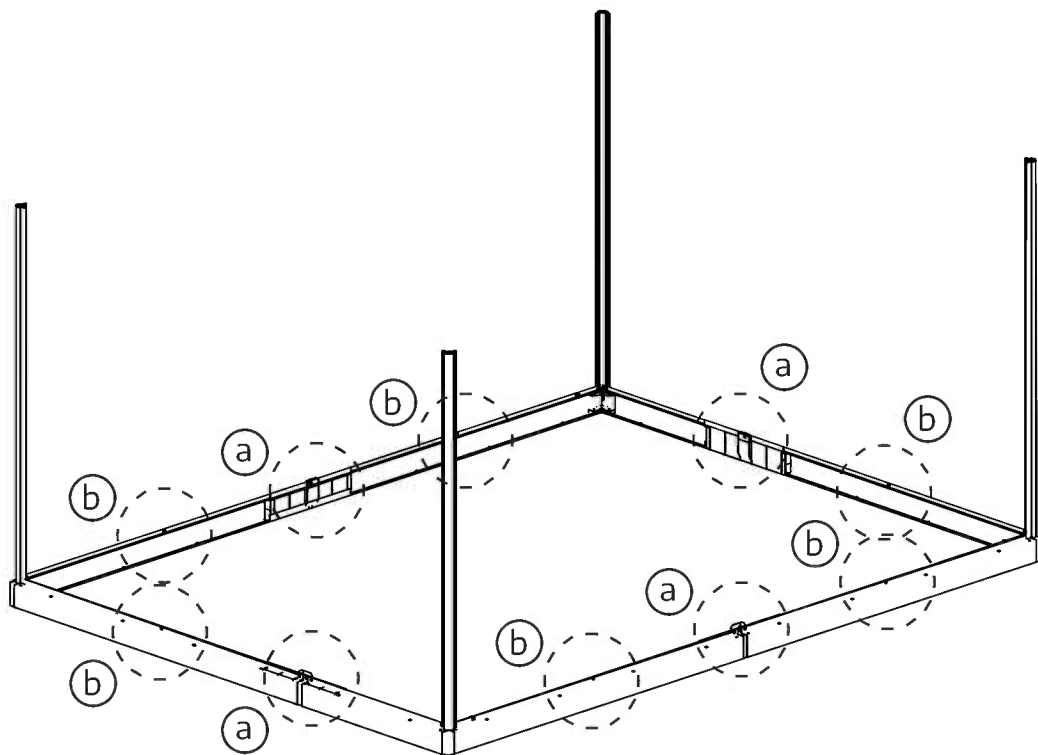

6



Determines the front side of the greenhouse.

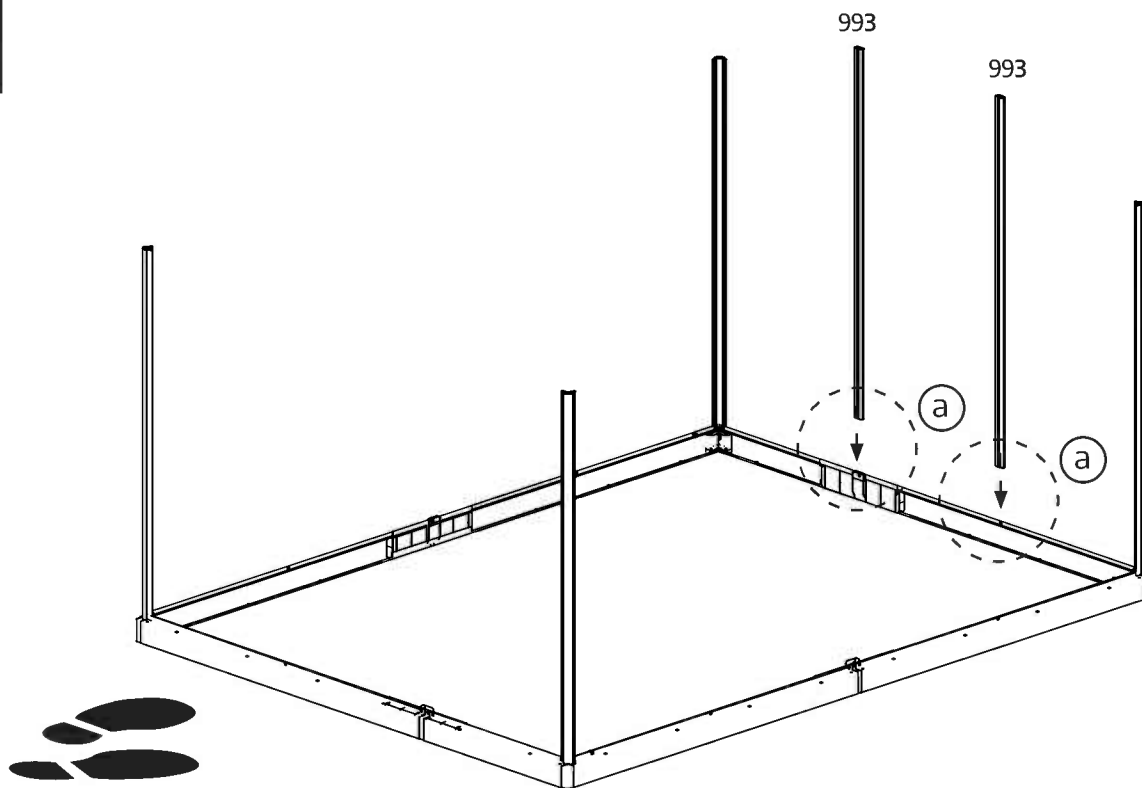
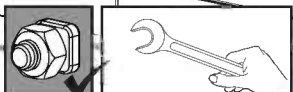
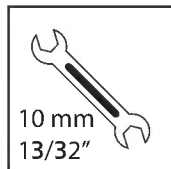
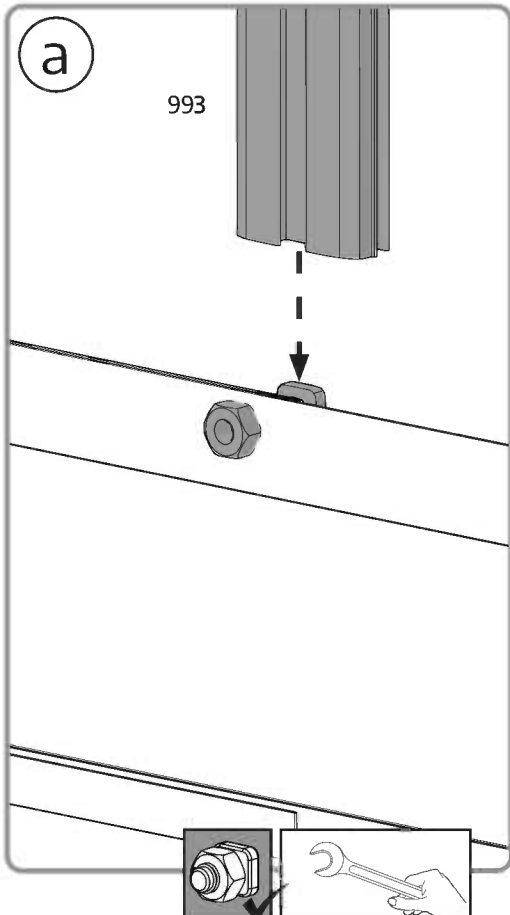
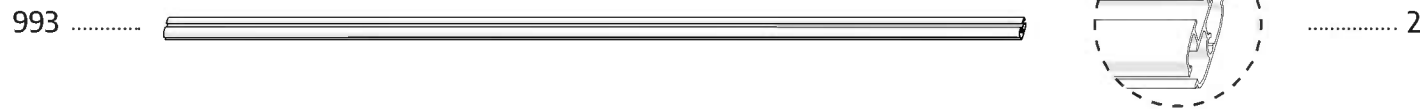
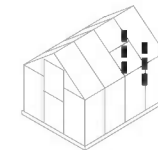

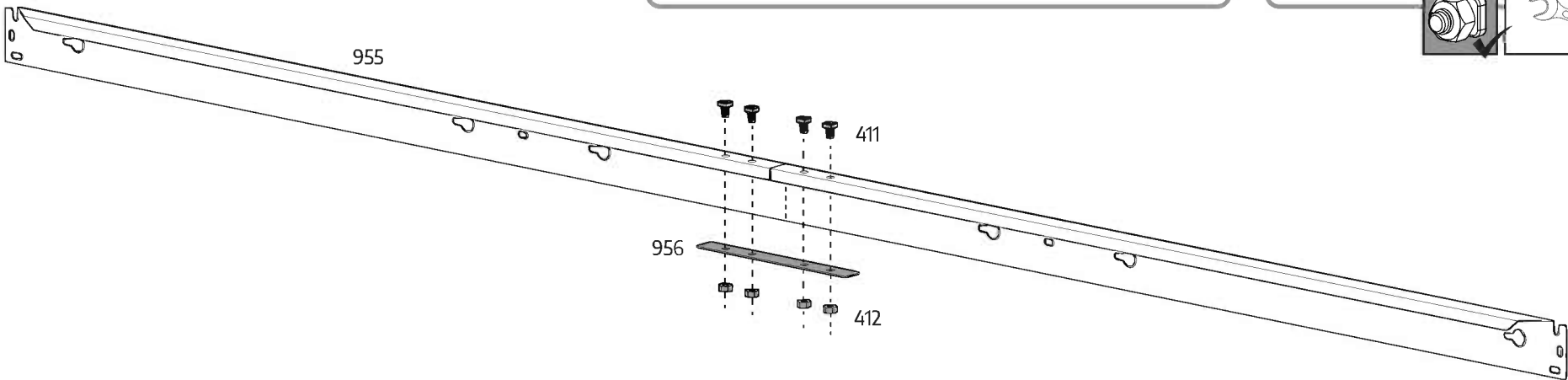
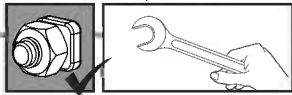
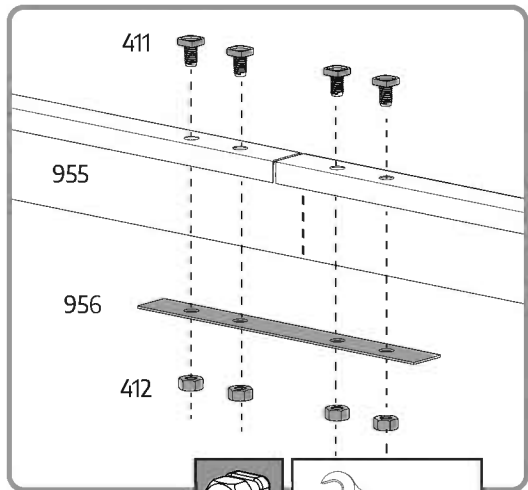
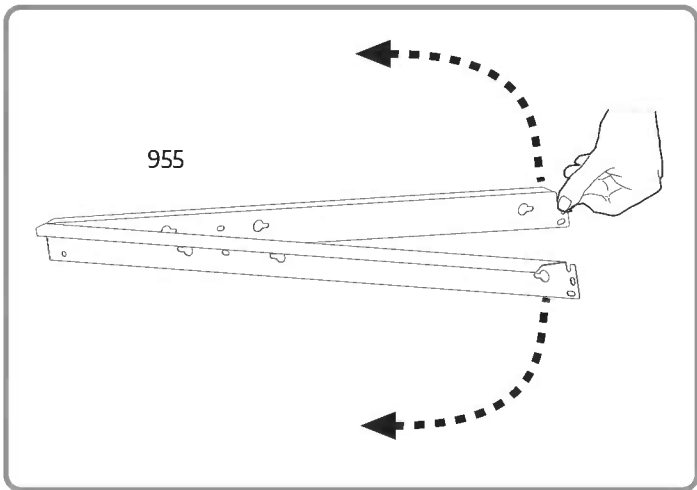
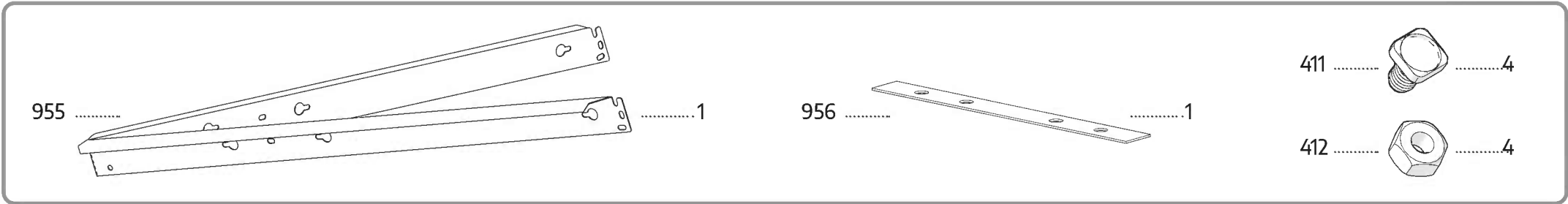
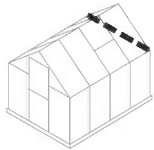

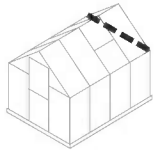

7314 2

411 8

412 8

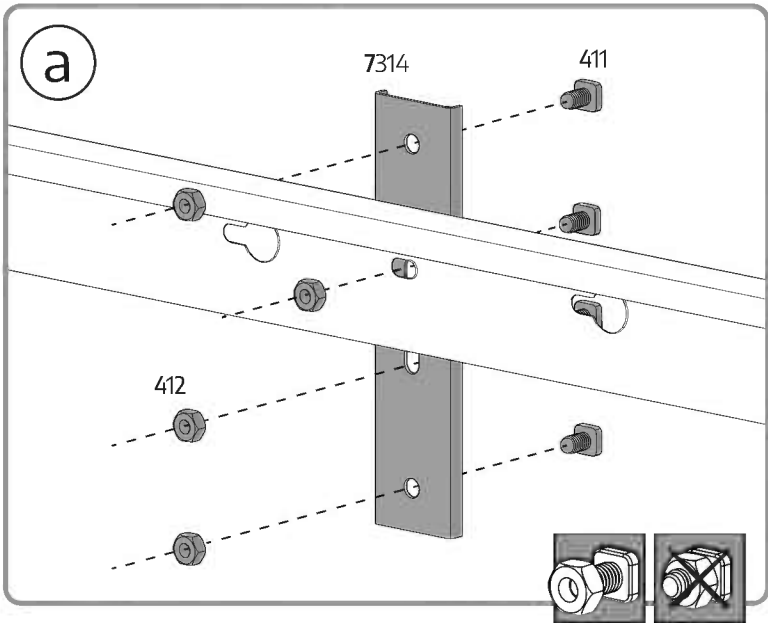
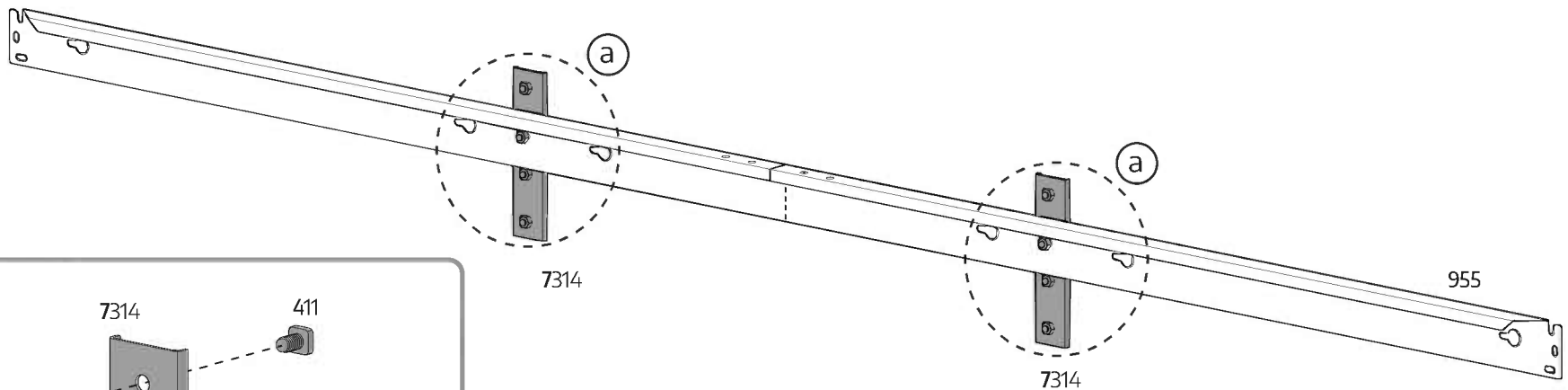

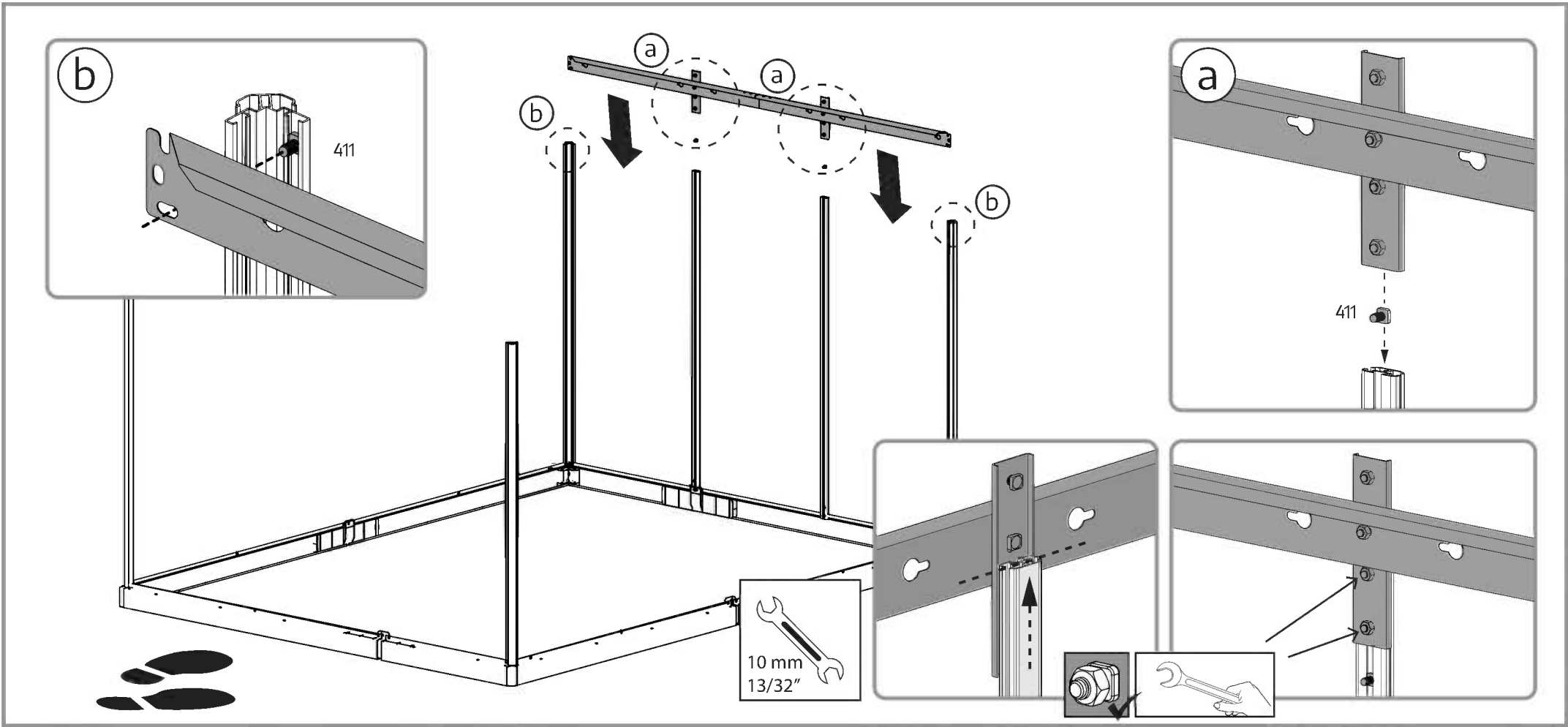
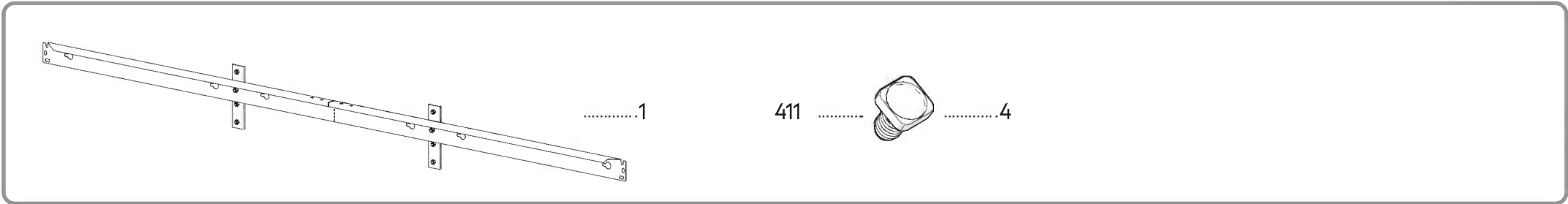

10



The oval hole in the crossbars. #256 should always be assembled to the base of the greenhouse.

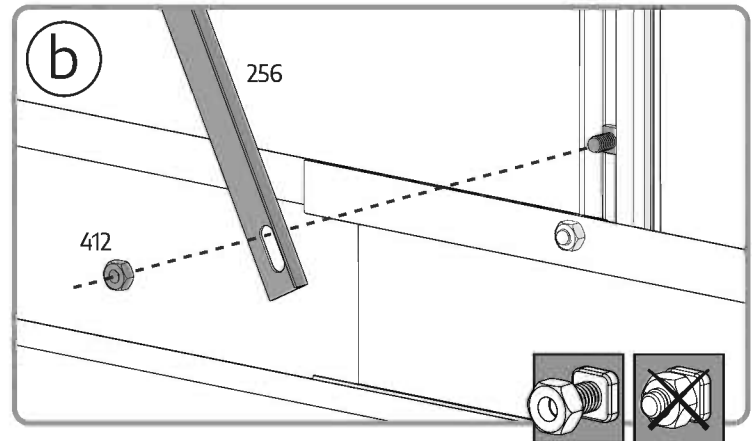
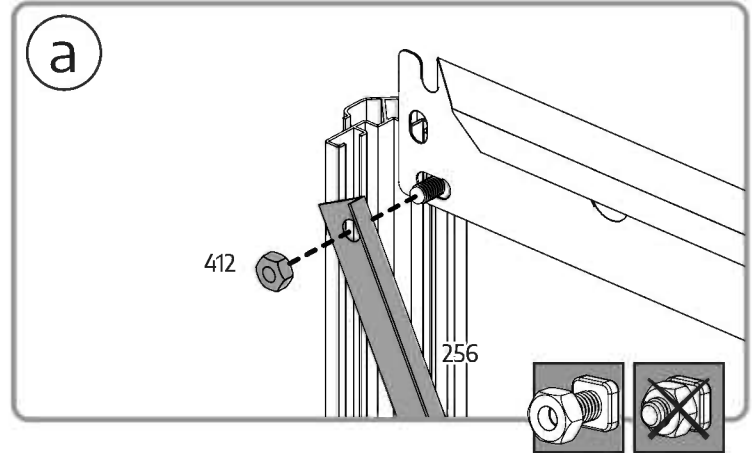
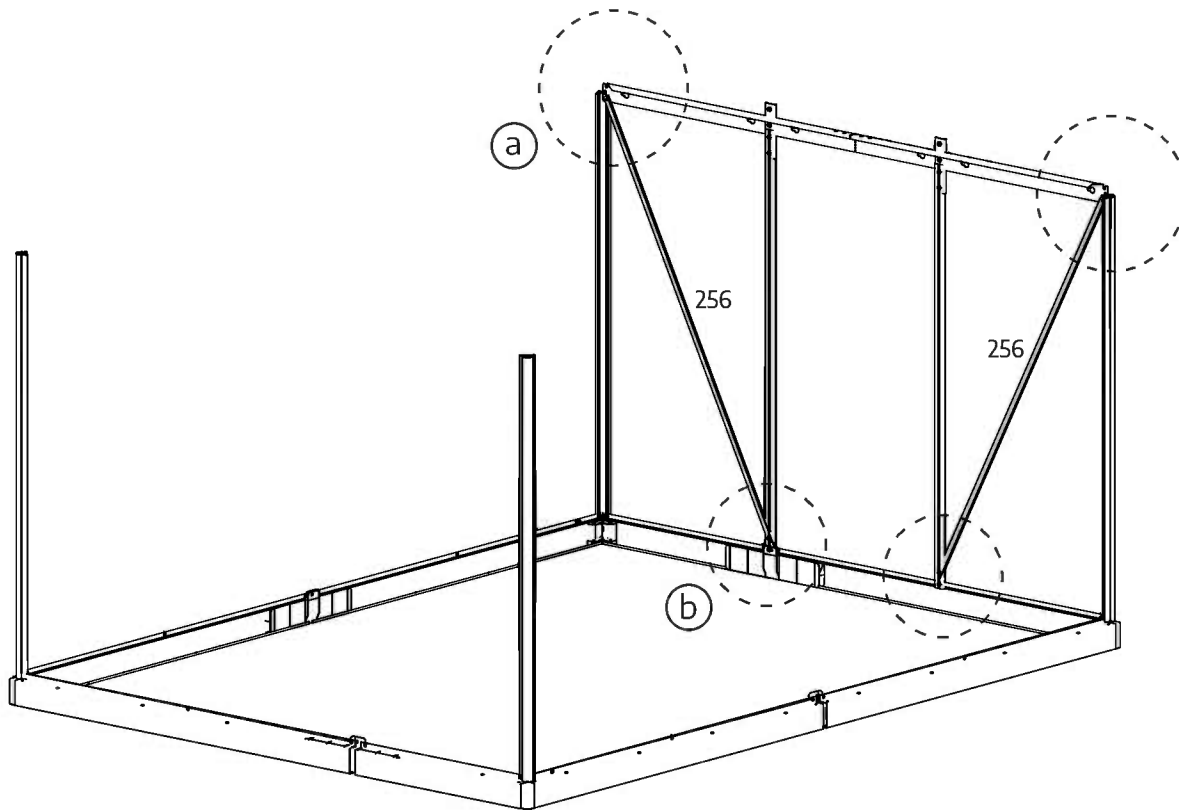
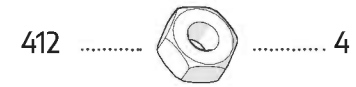
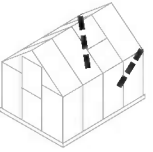

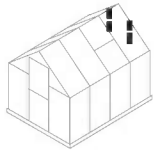

7312  1

7313  1

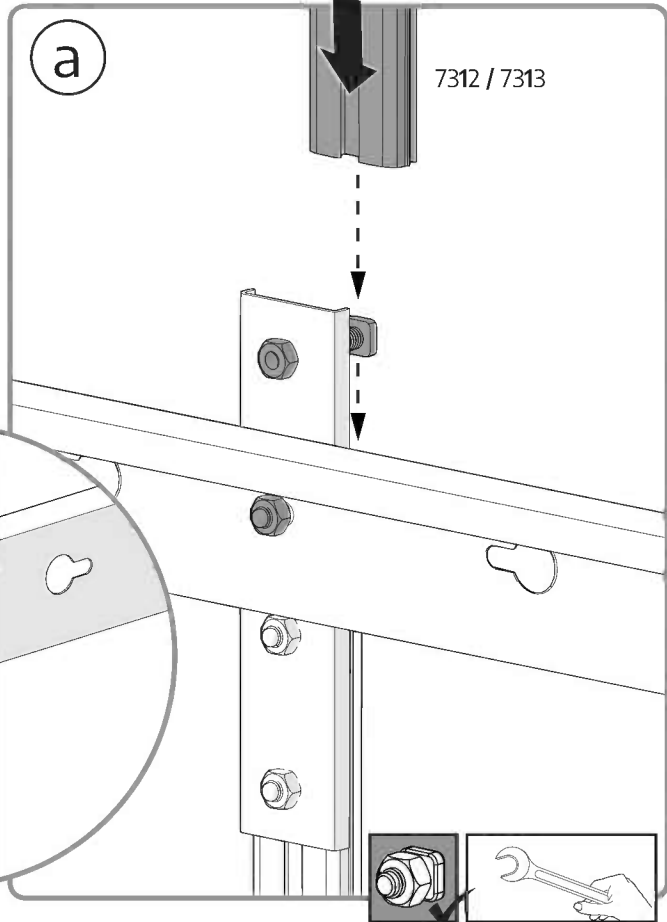
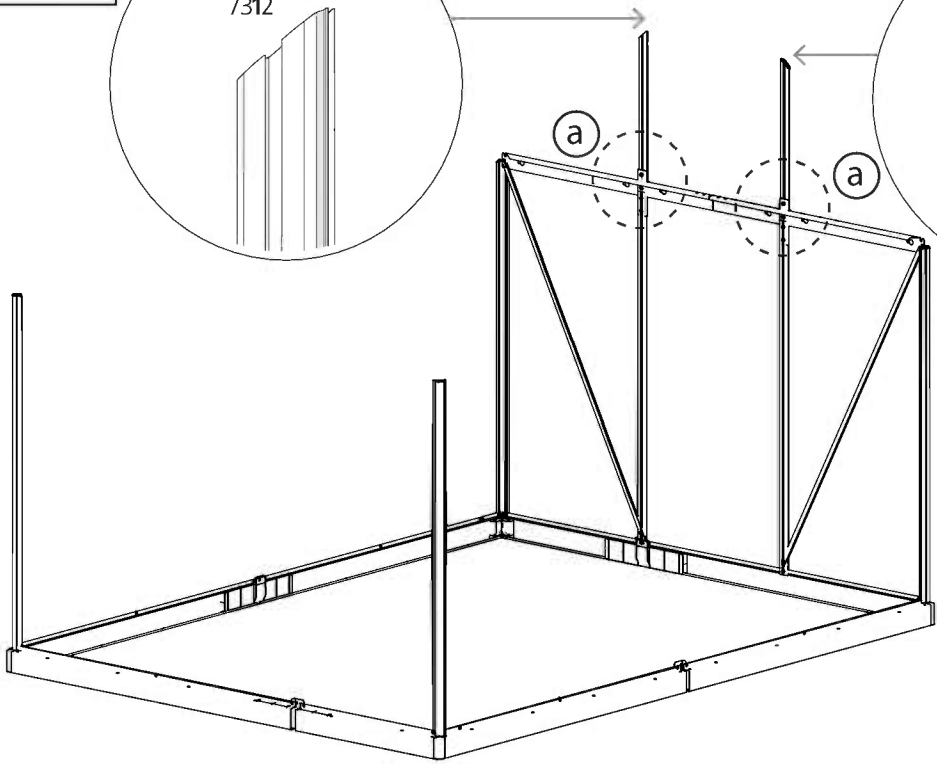
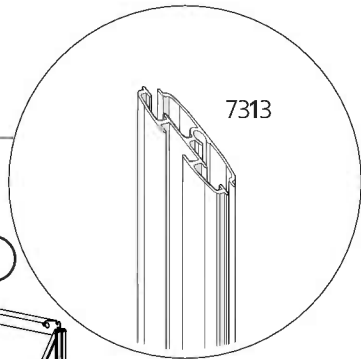
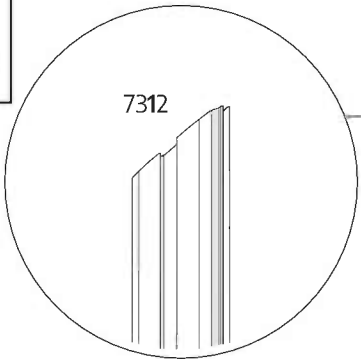



In order to insert profile #8378 in between two #7311 profiles, please apply silicone lubricant spray.

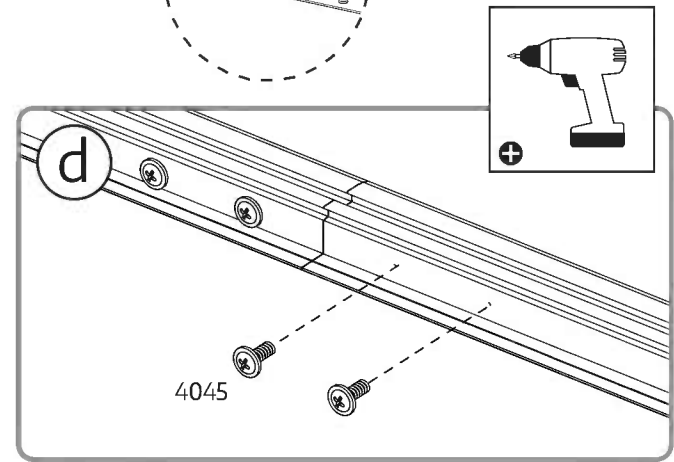
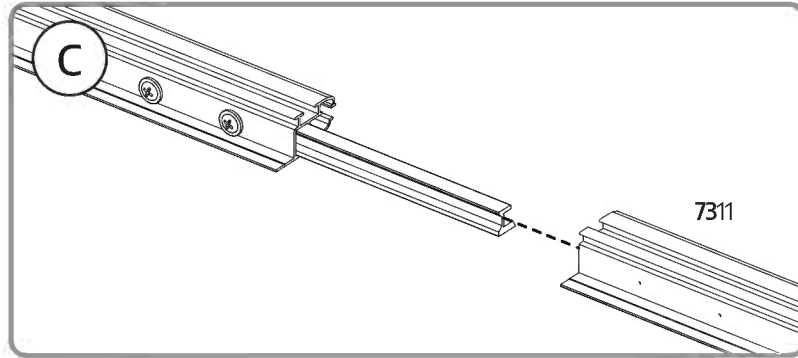
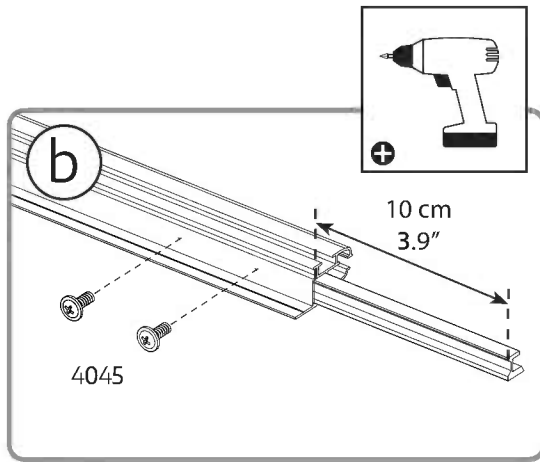
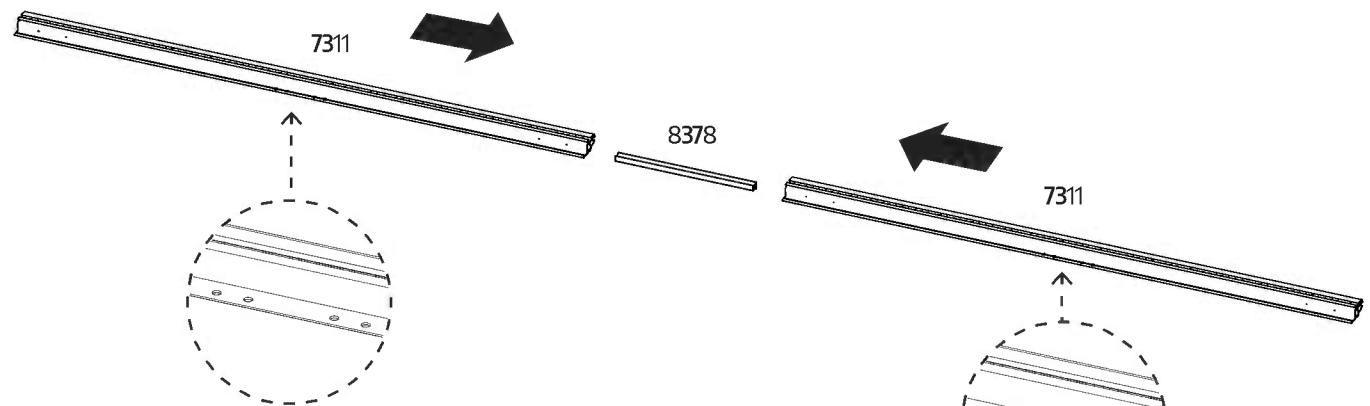
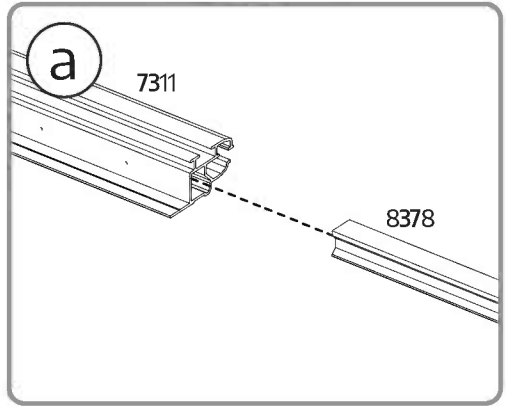
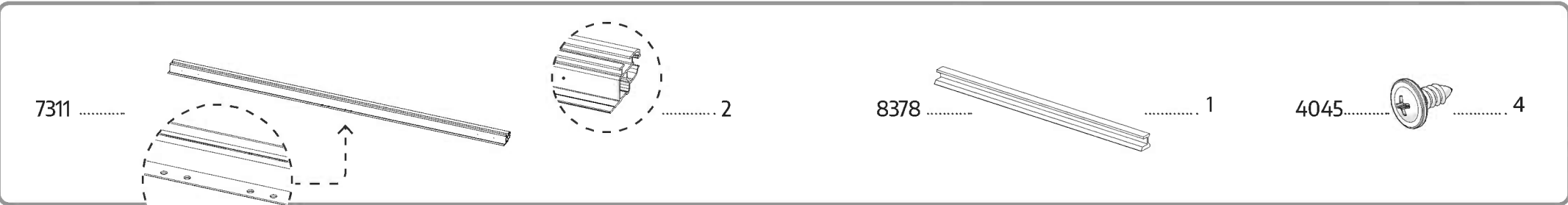
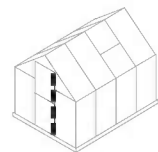



In order to insert profile #8378 in between two #7310 profiles, please apply silicone lubricant spray.

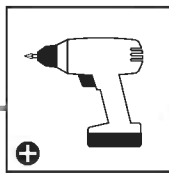
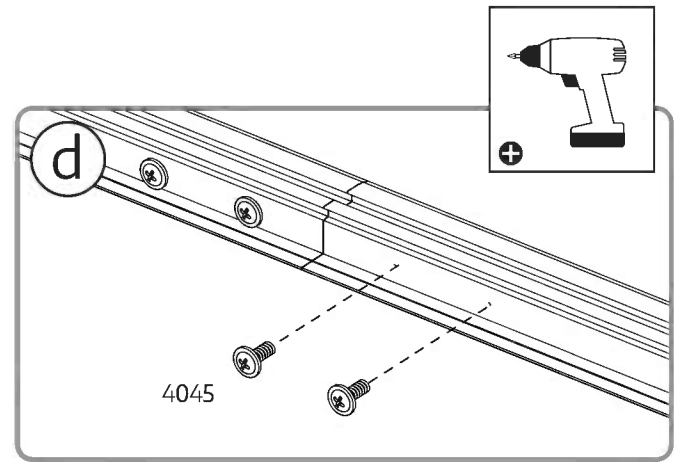
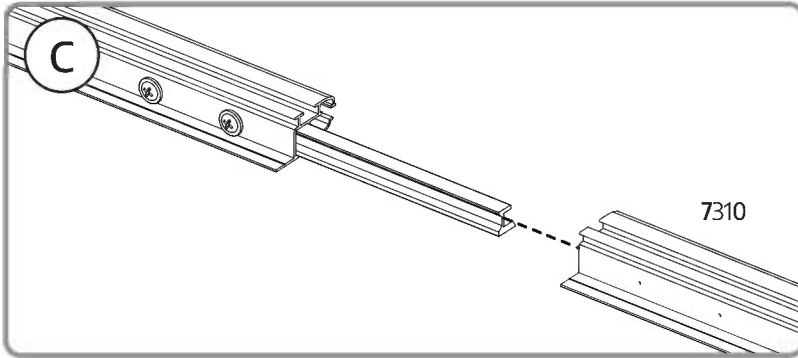
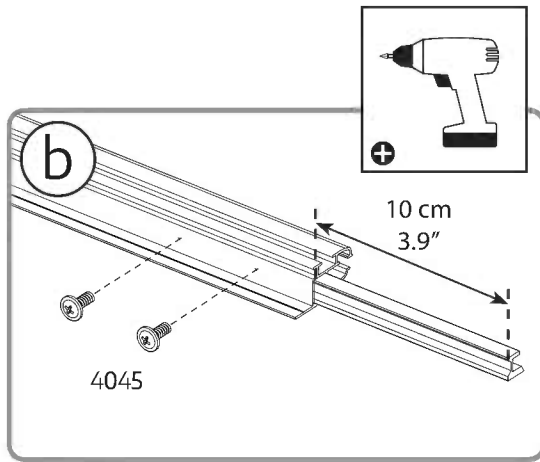
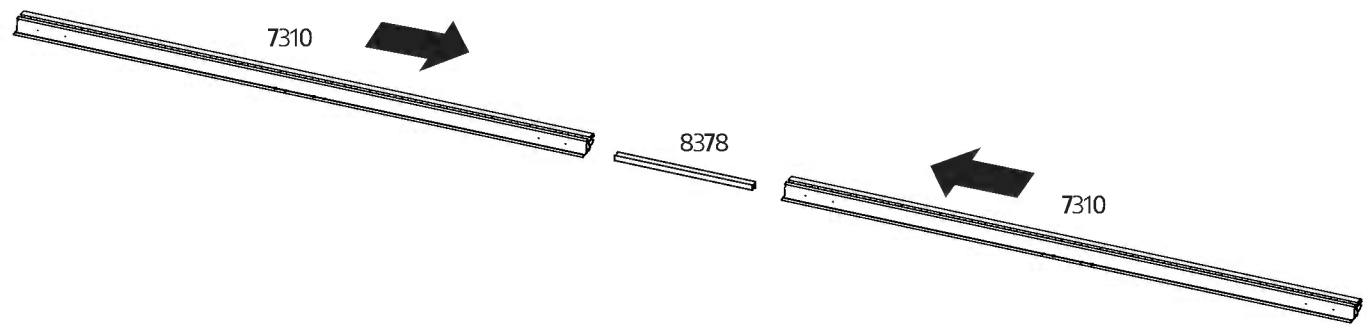
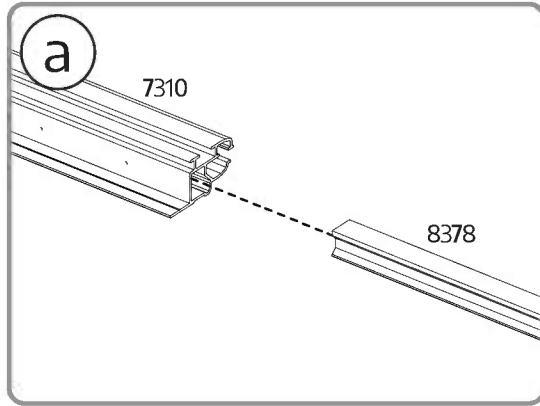
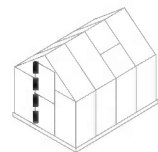



Determines door direction door post #7311 is where door hinges will be located.

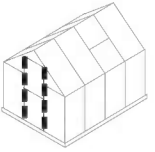

7310  1

7311  1

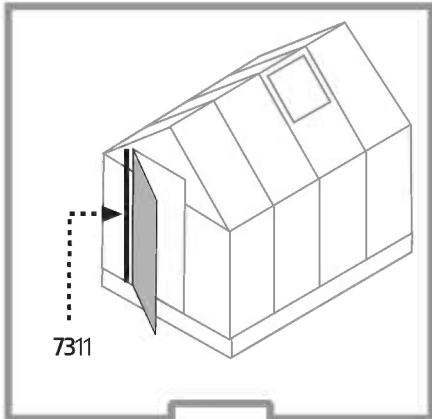

or

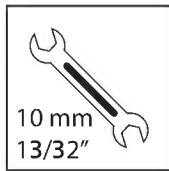
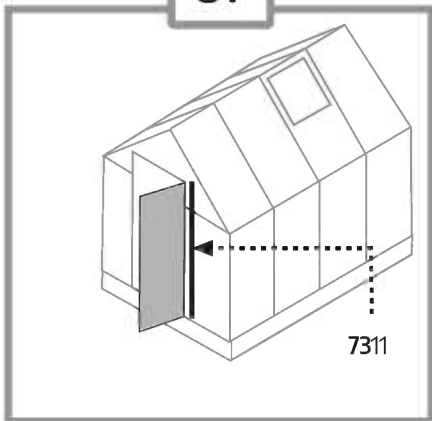

10 mm
13/32"

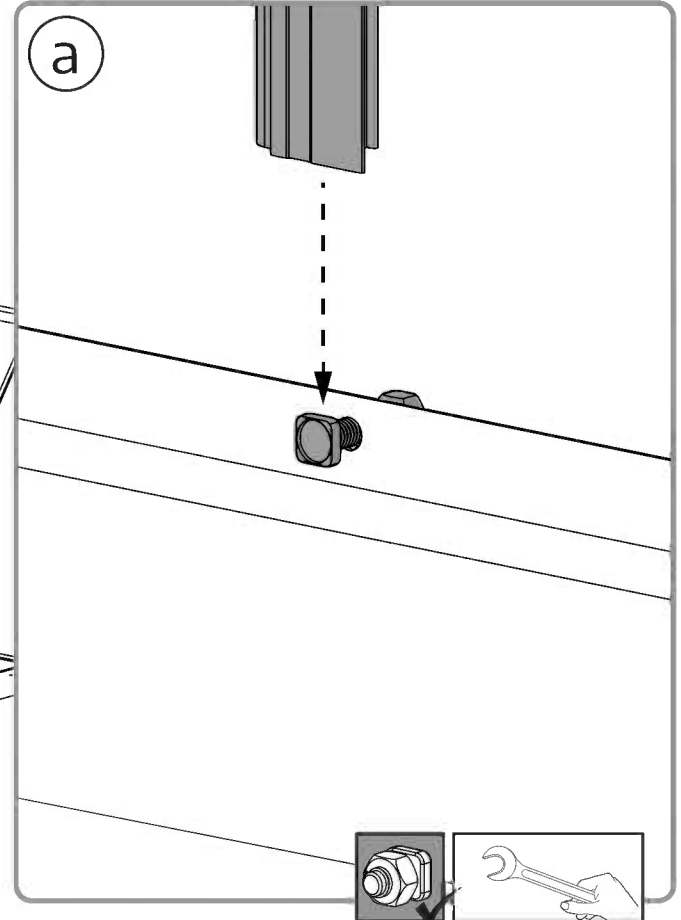
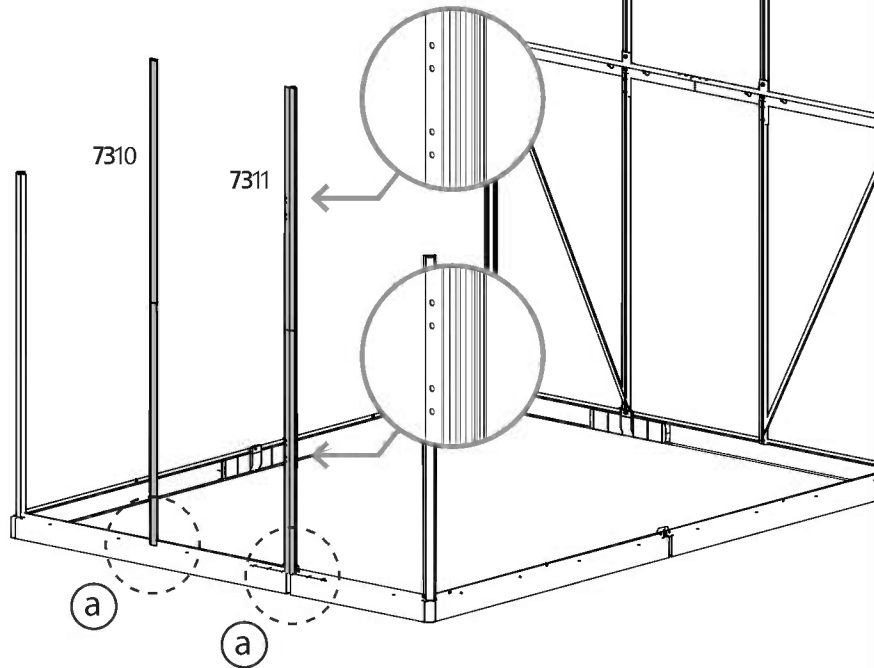

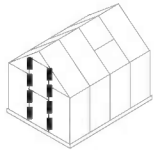

411  6

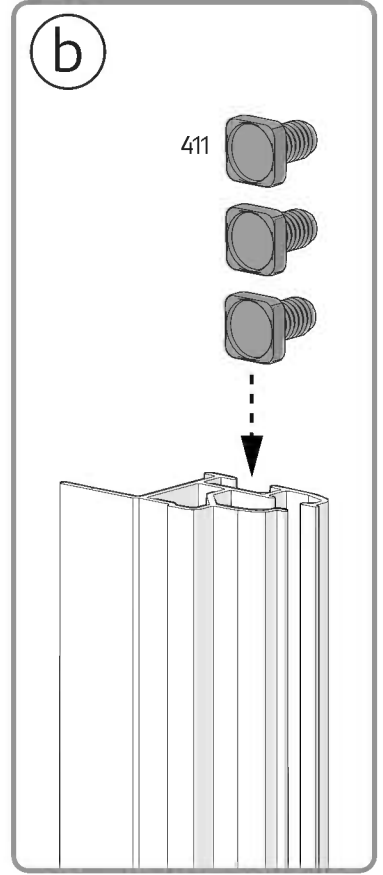
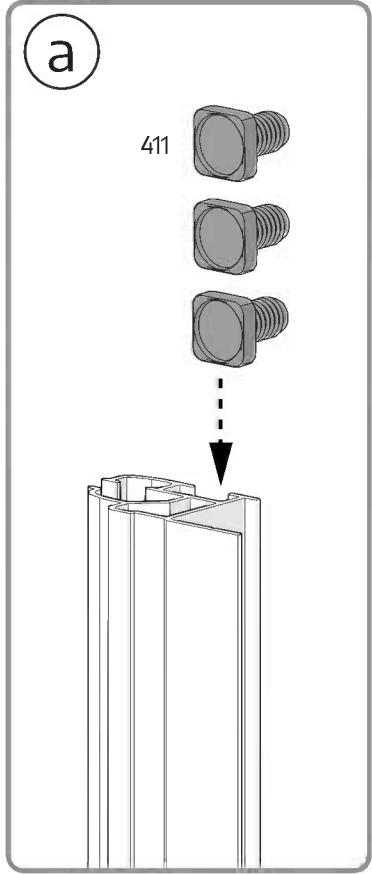
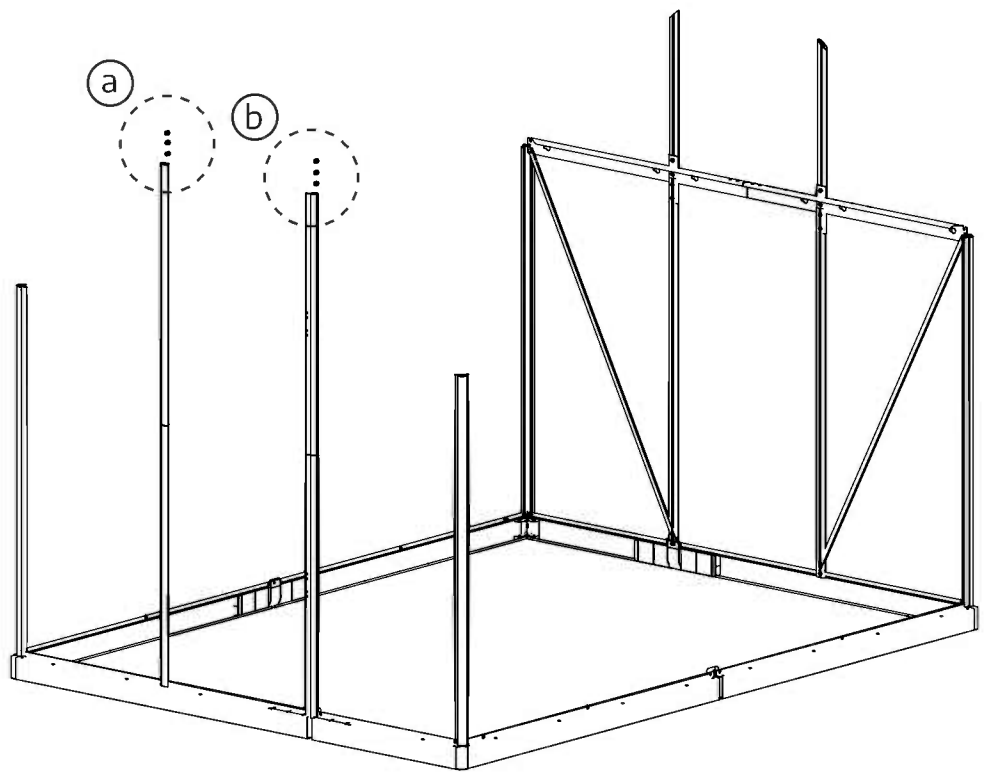



The oval hole in the crossbars. #256 should always be assembled to the base of the greenhouse.

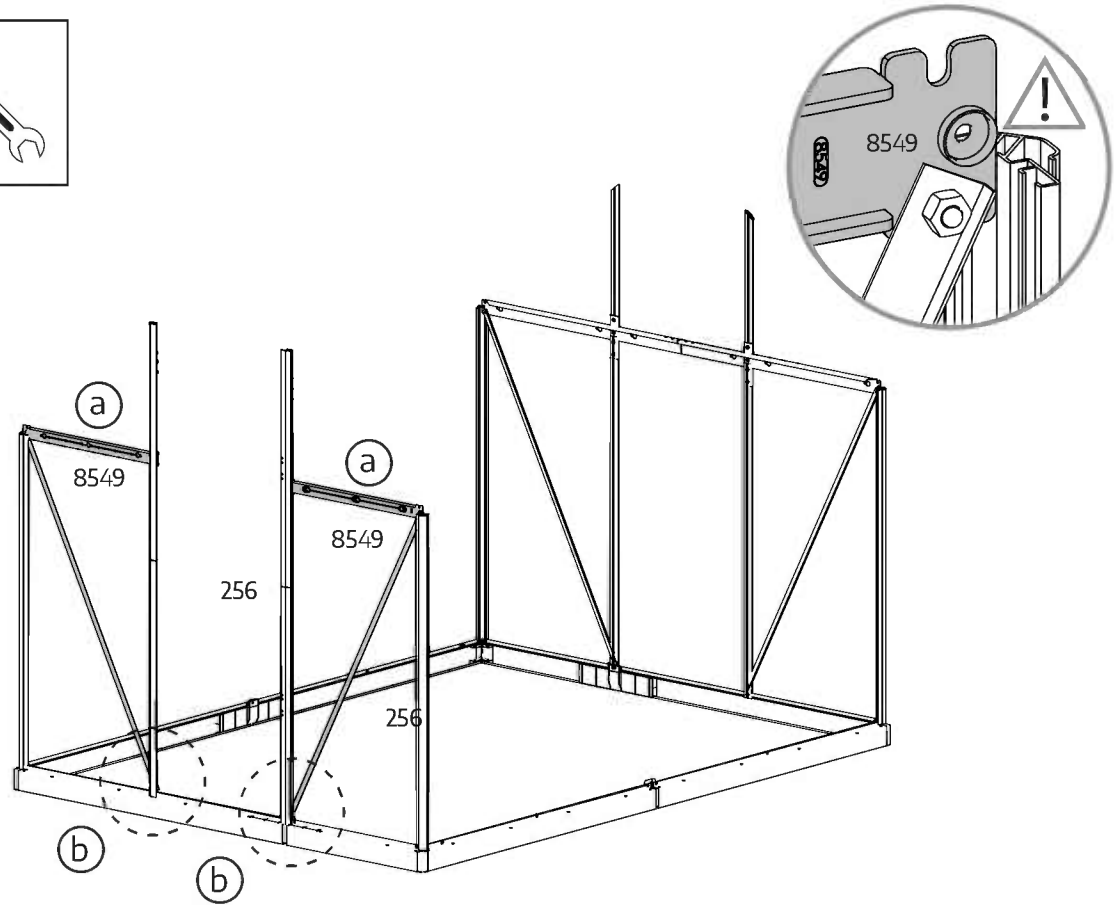
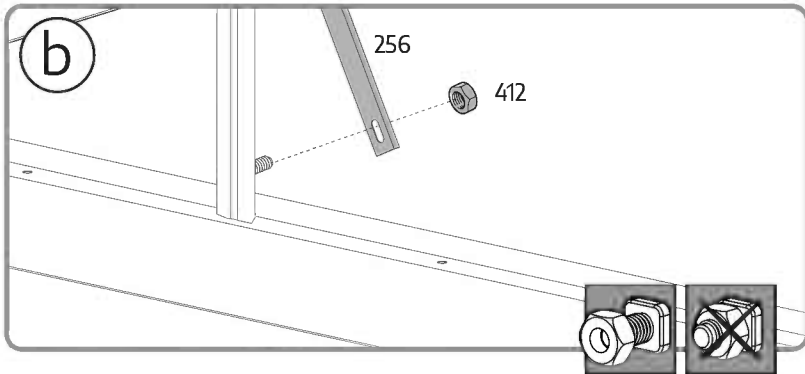
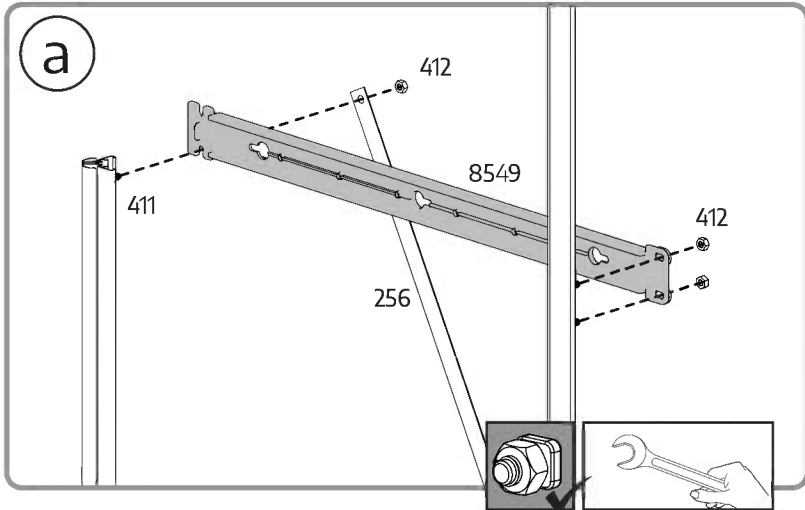
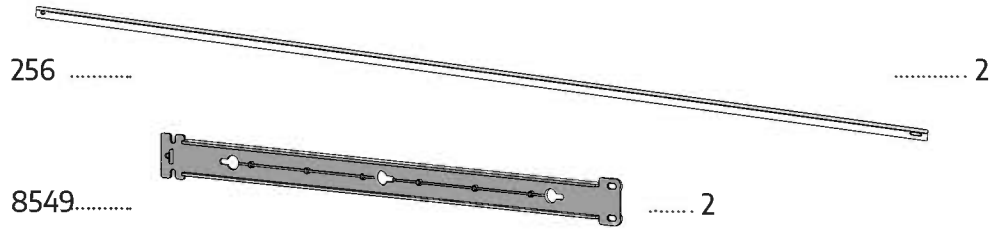
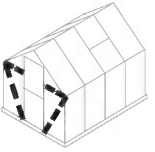

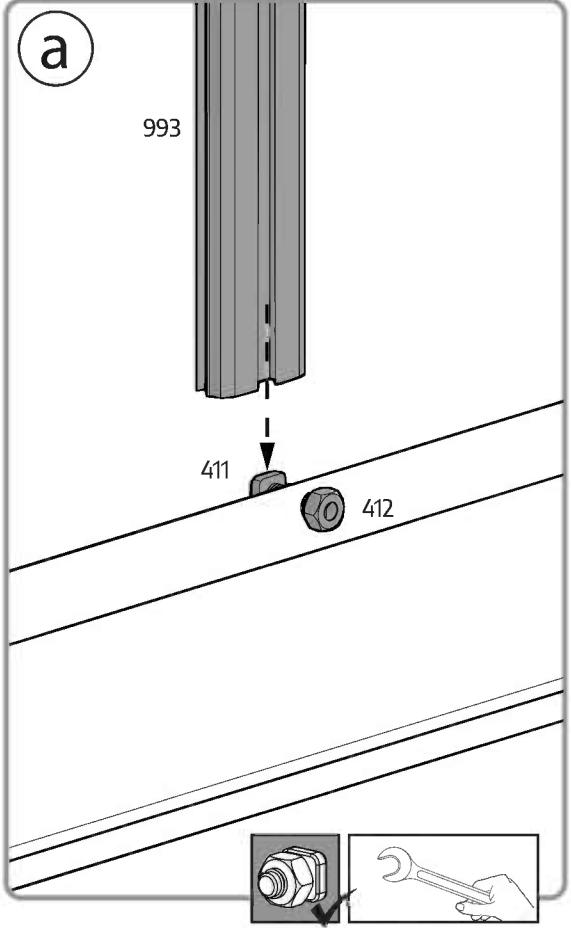
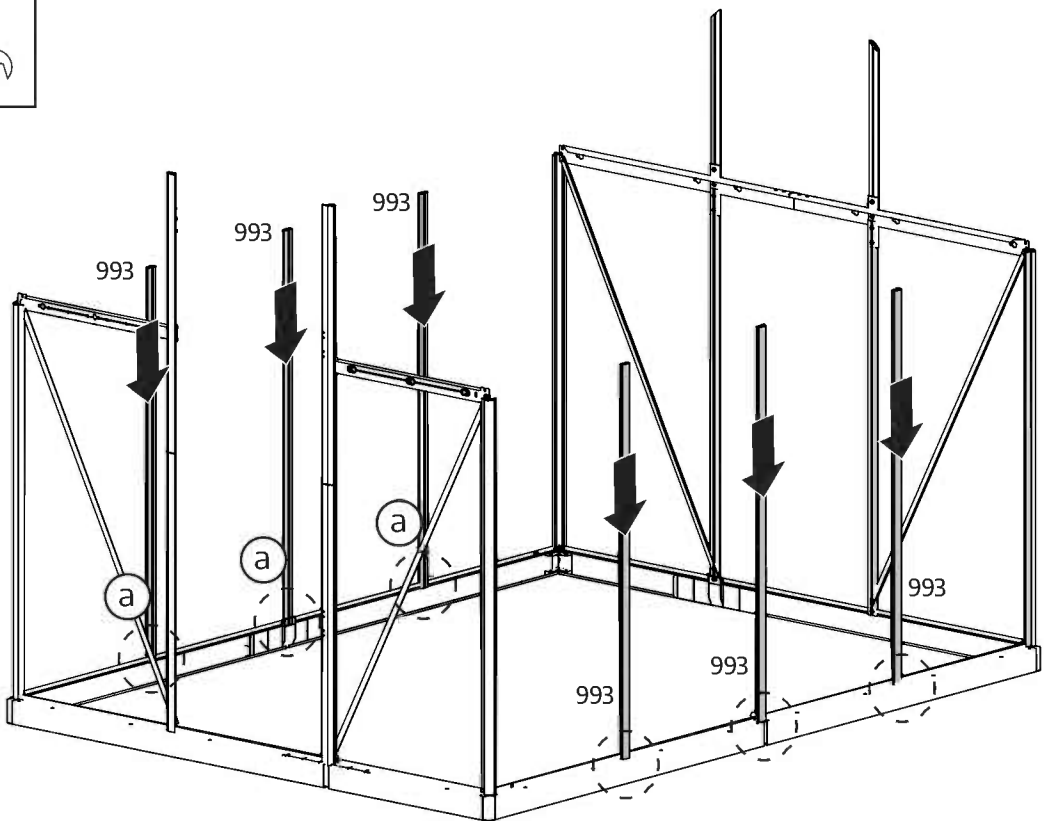
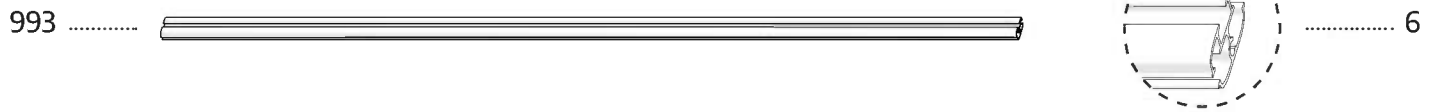
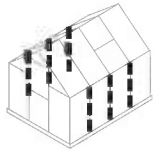

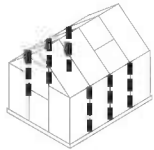

411 4

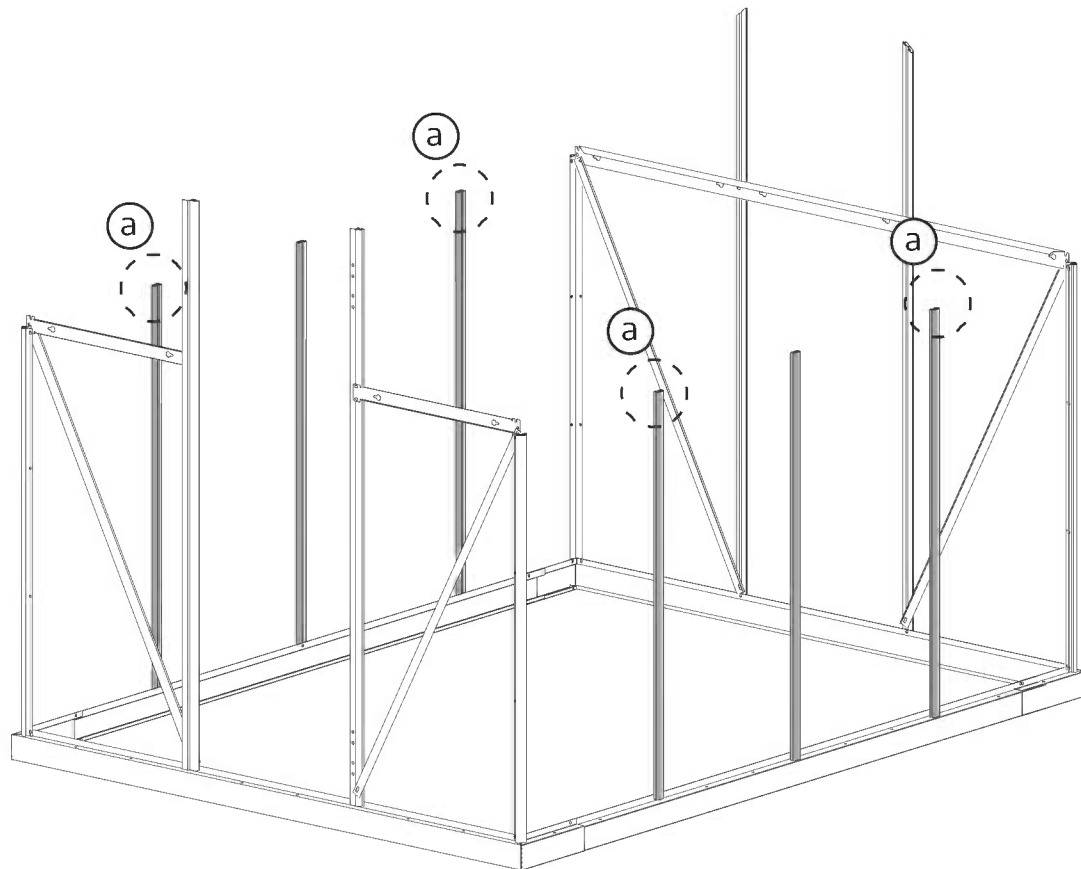
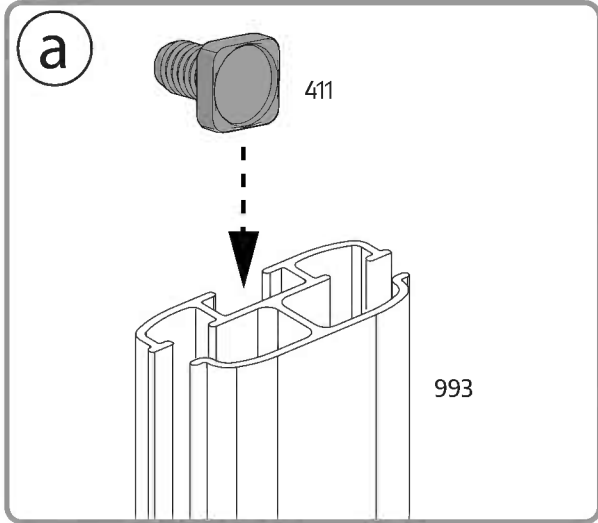



The oval hole in the crossbars. #256 should always be assembled to the base of the greenhouse.

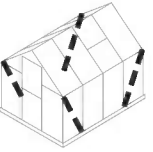

256 4

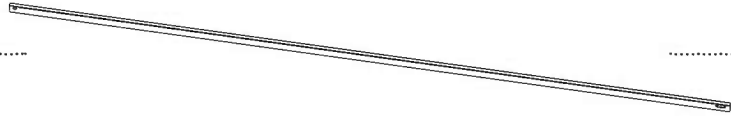

411 4



412 8

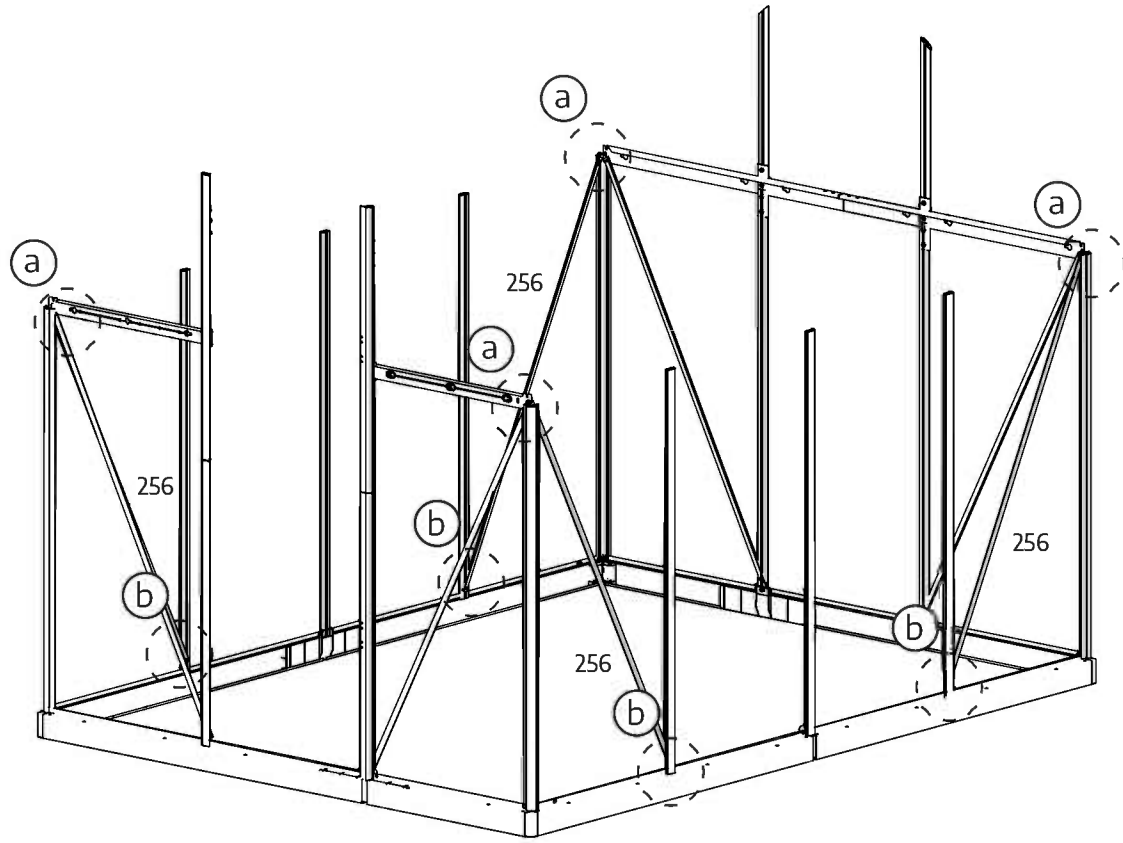
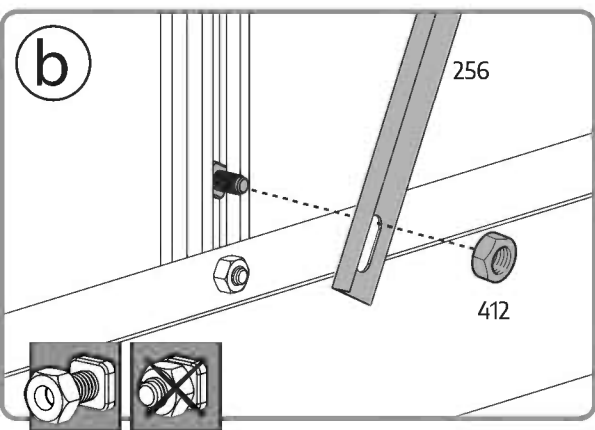
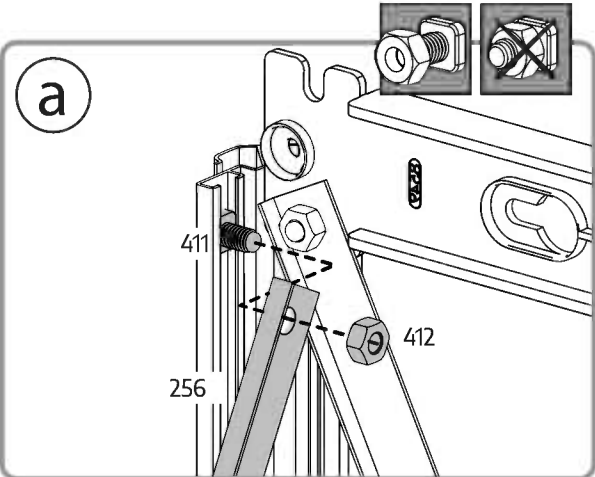

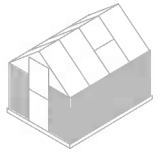

7011

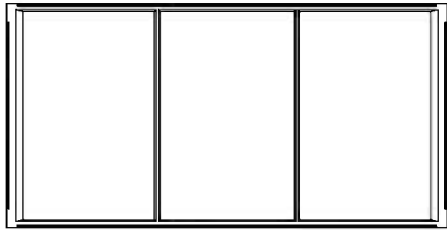

..... 13

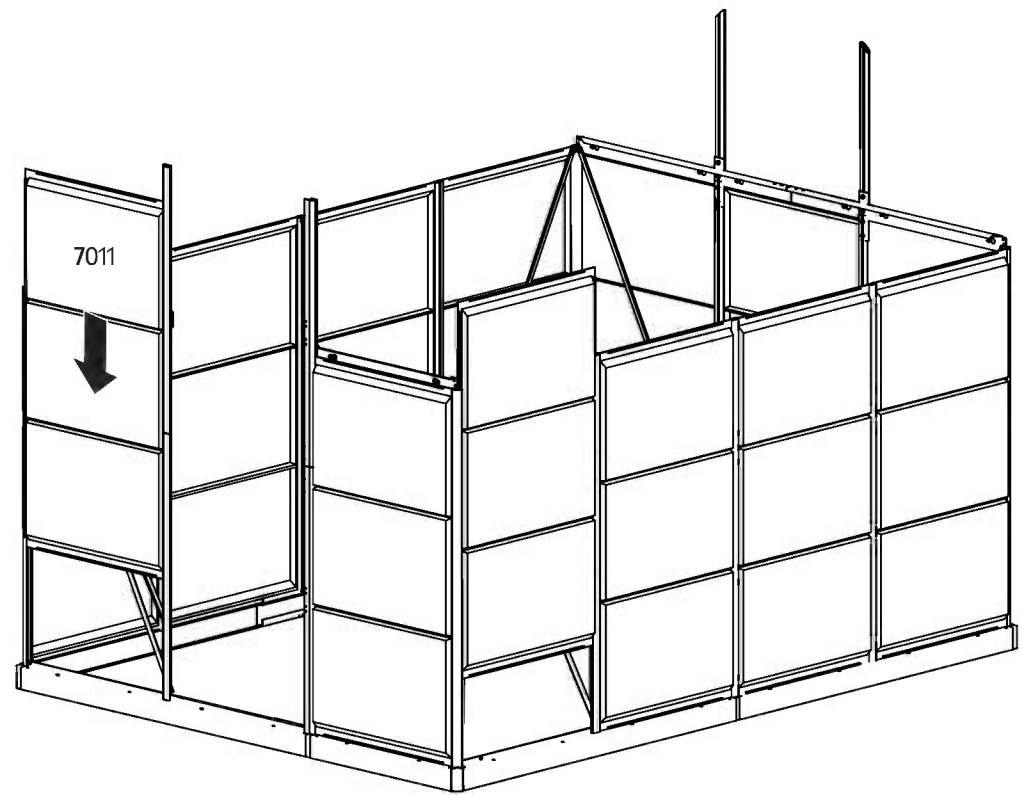
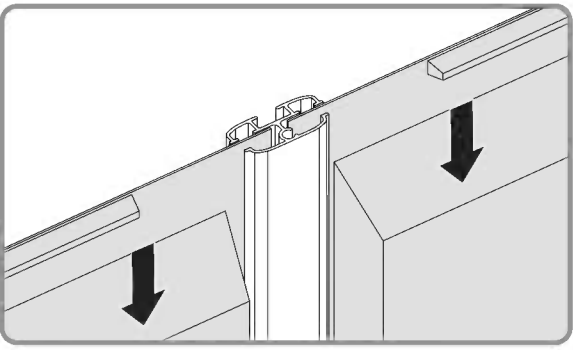
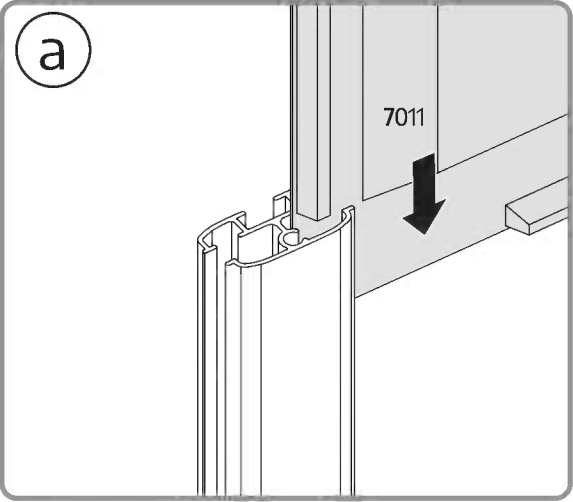

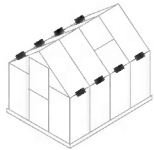

318 8

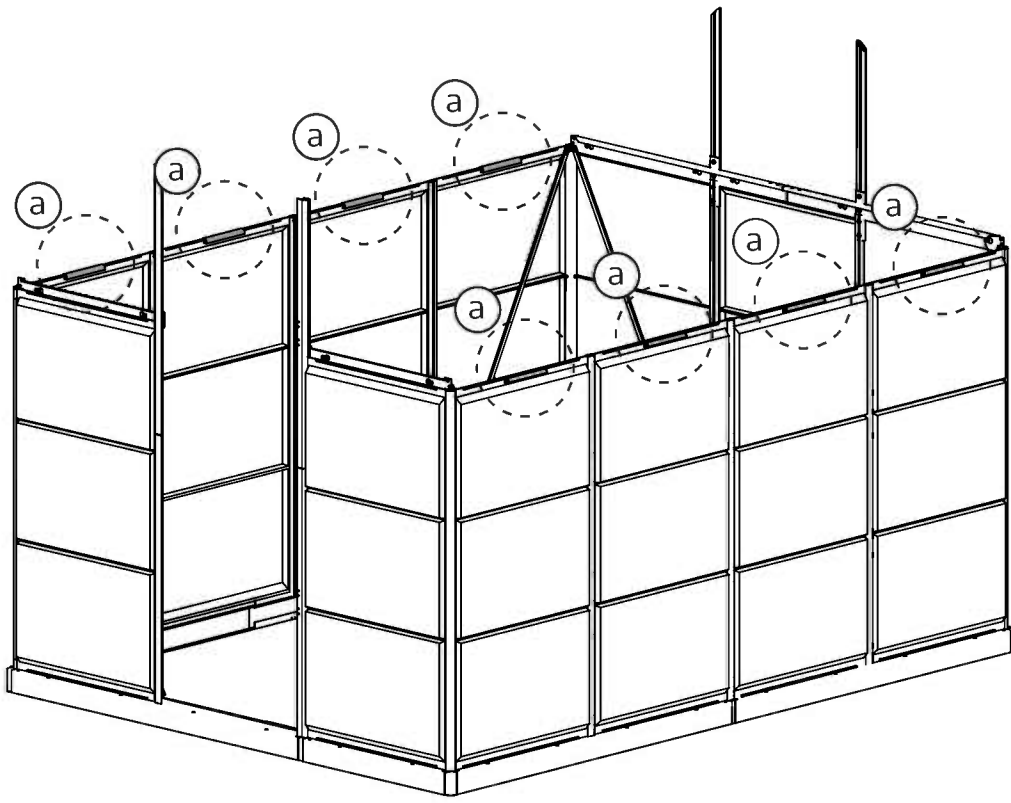
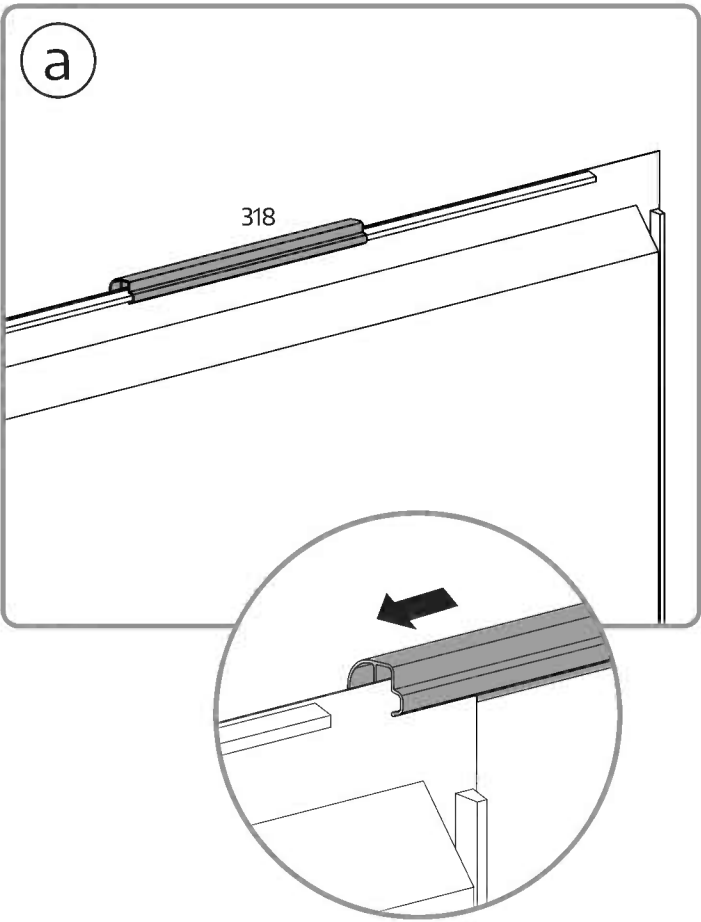
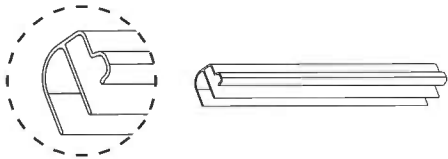

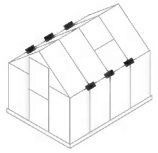

411 6

412 6

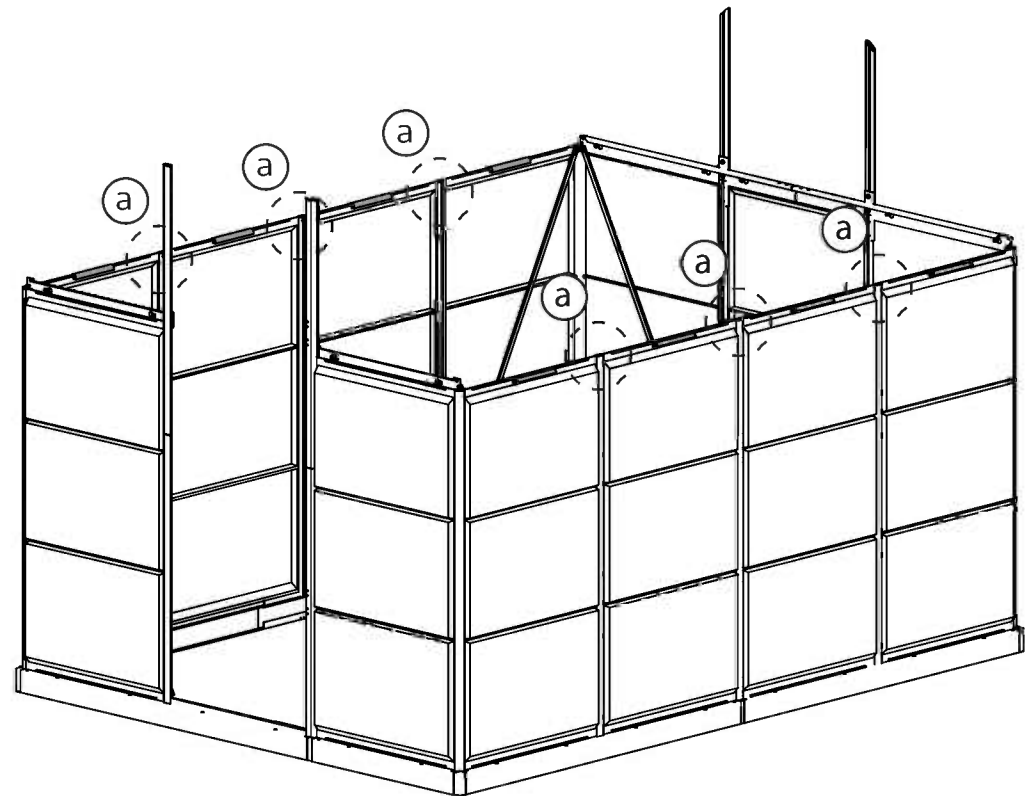
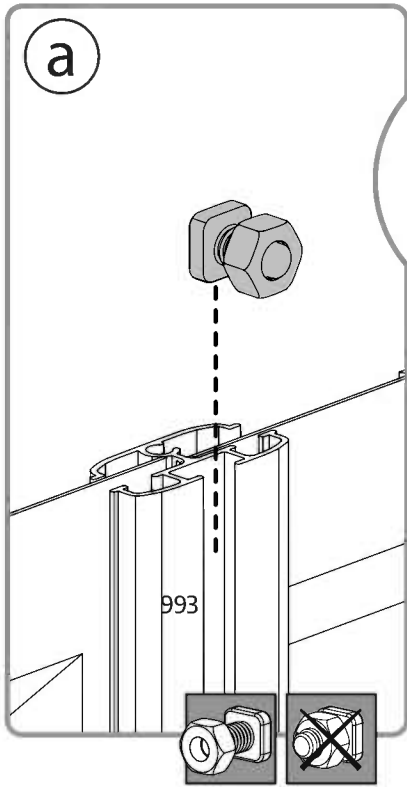

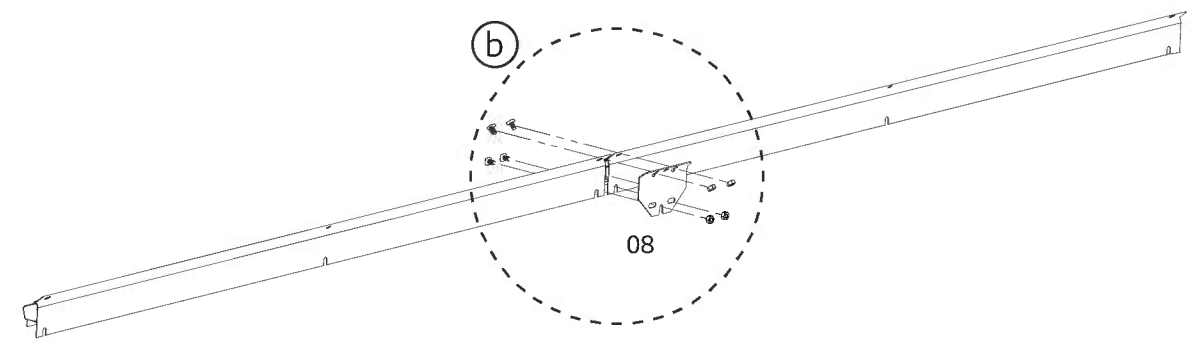
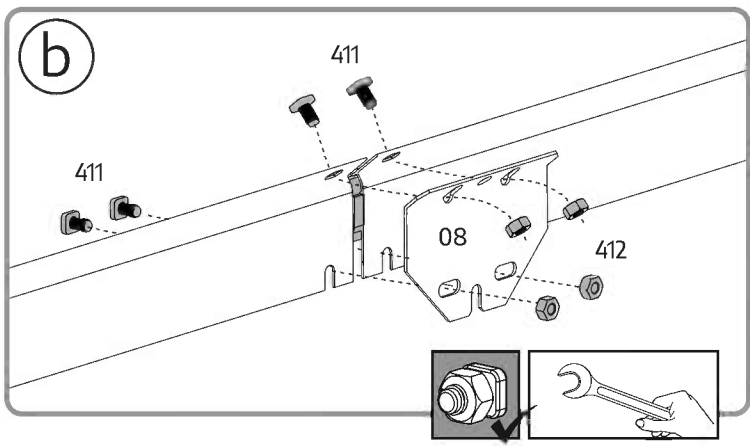
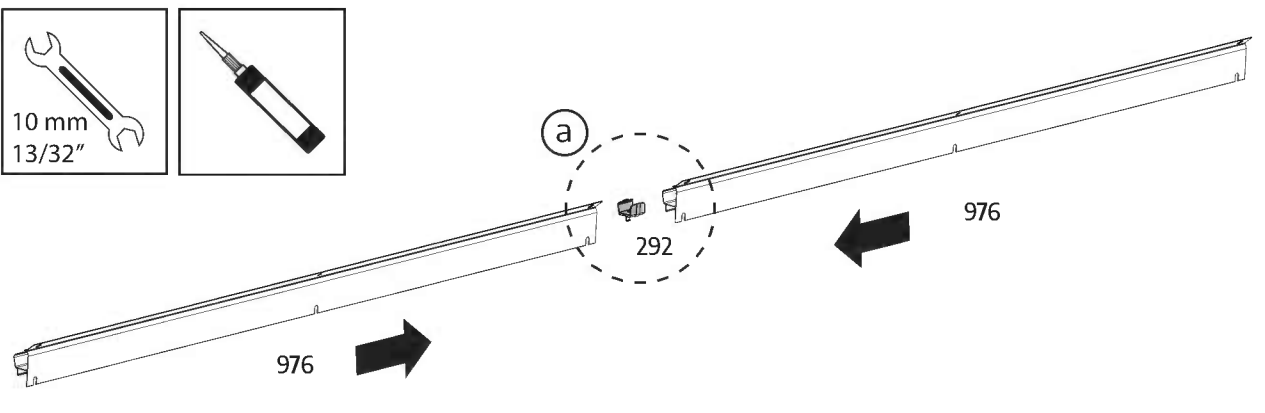
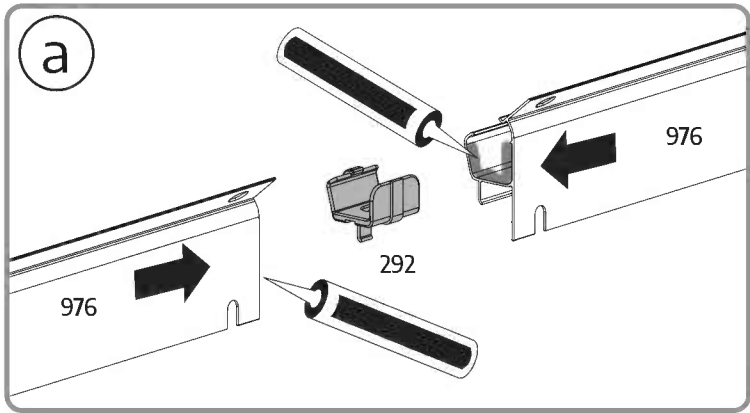
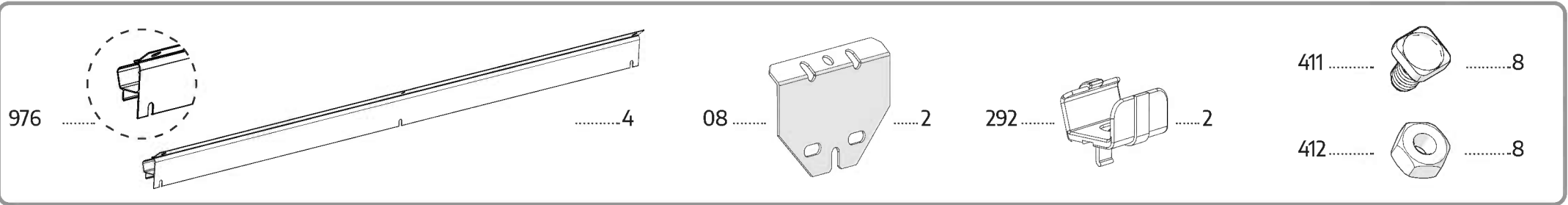

x2

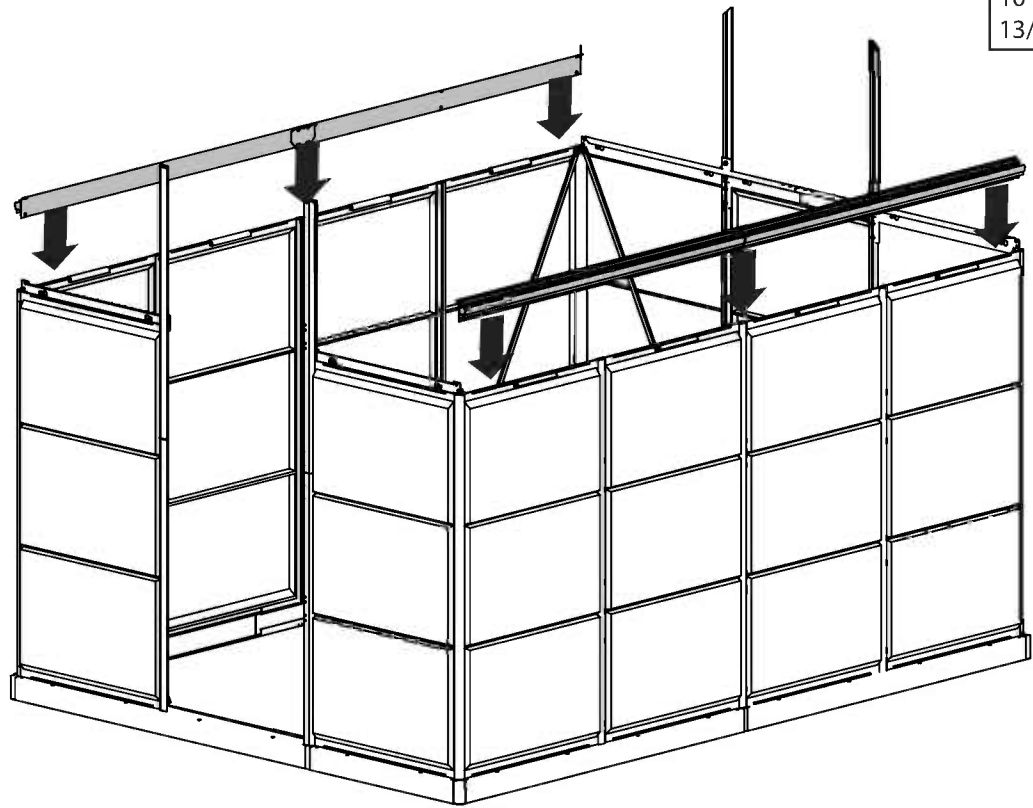
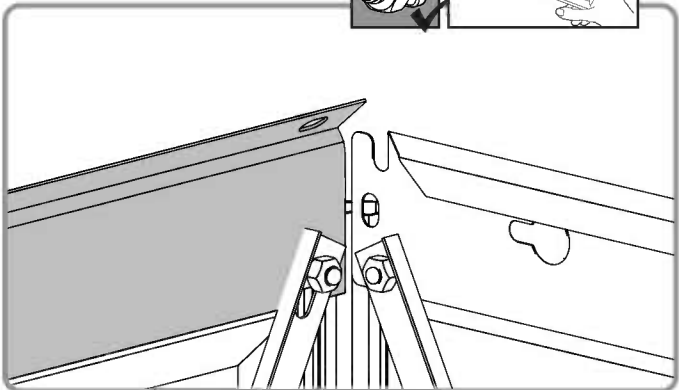
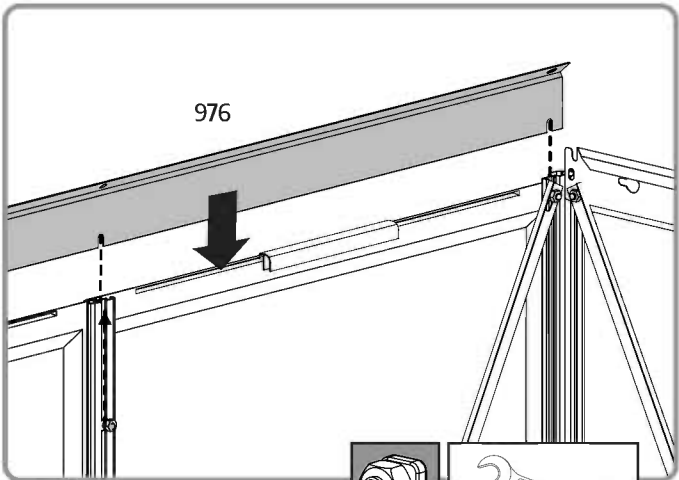
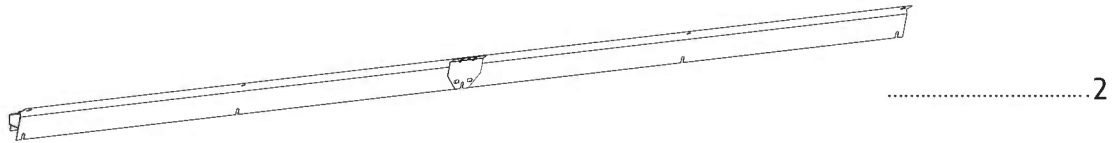

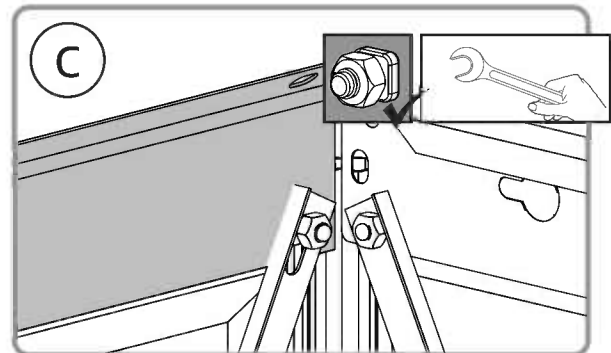
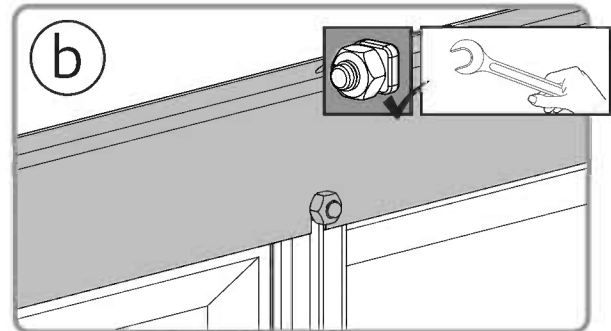
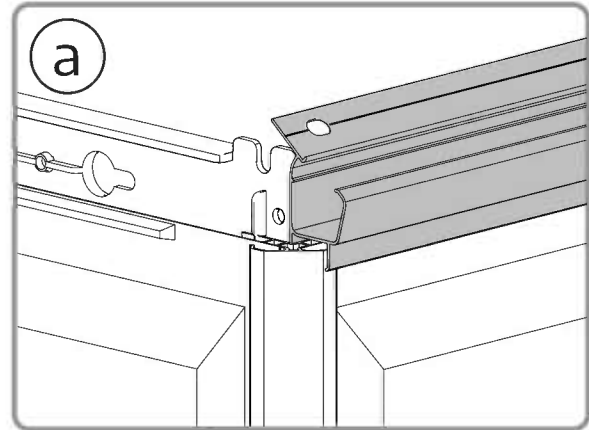
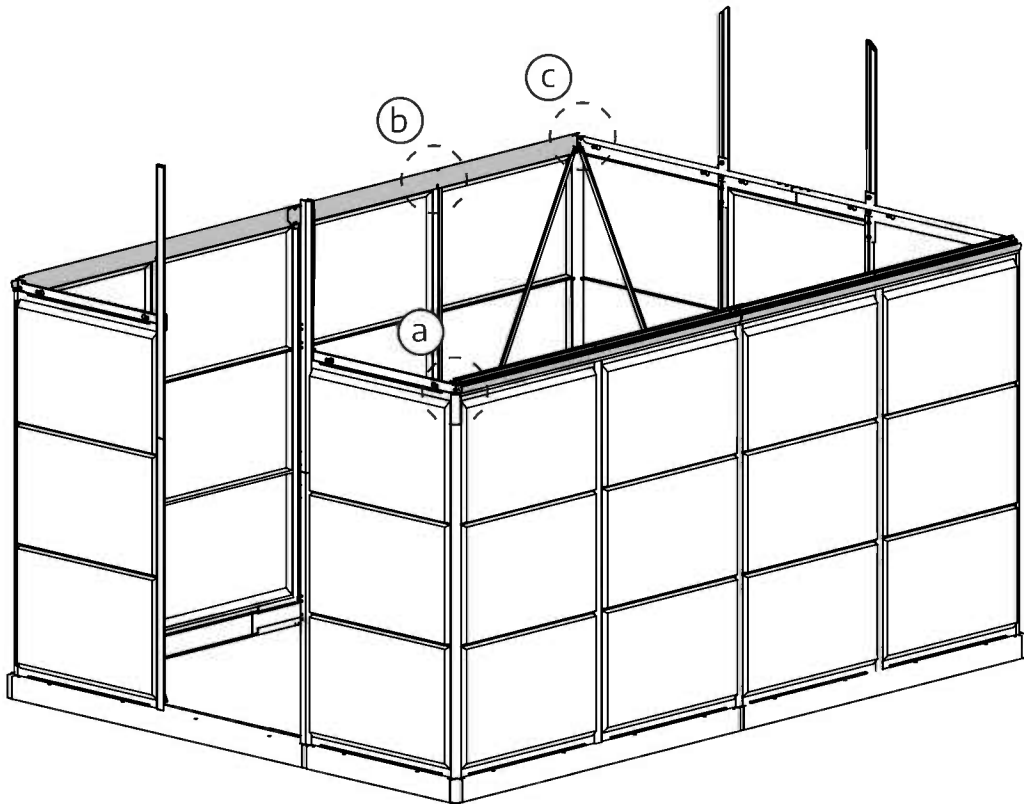
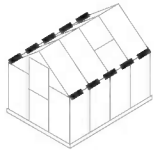



4008 2

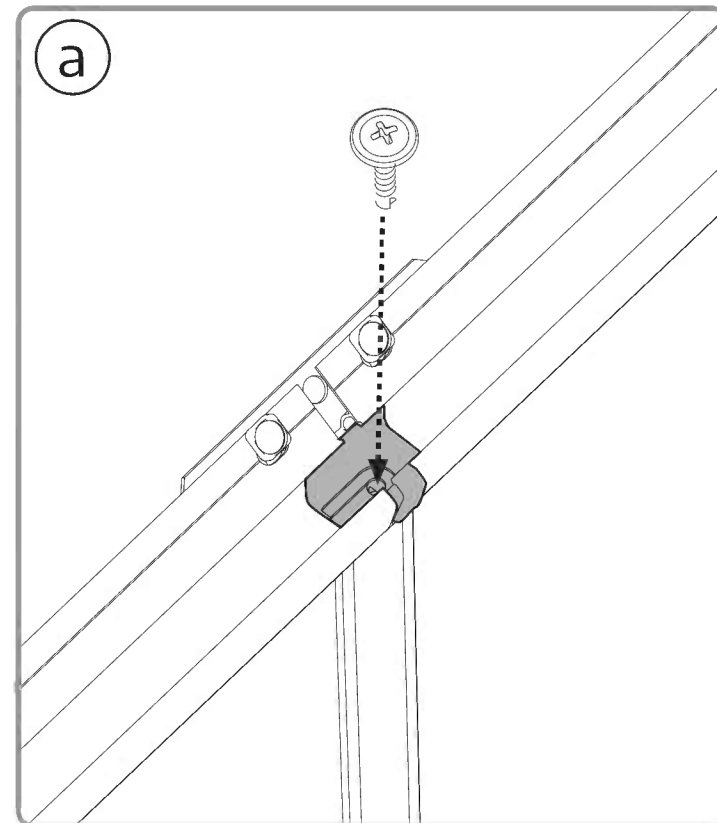
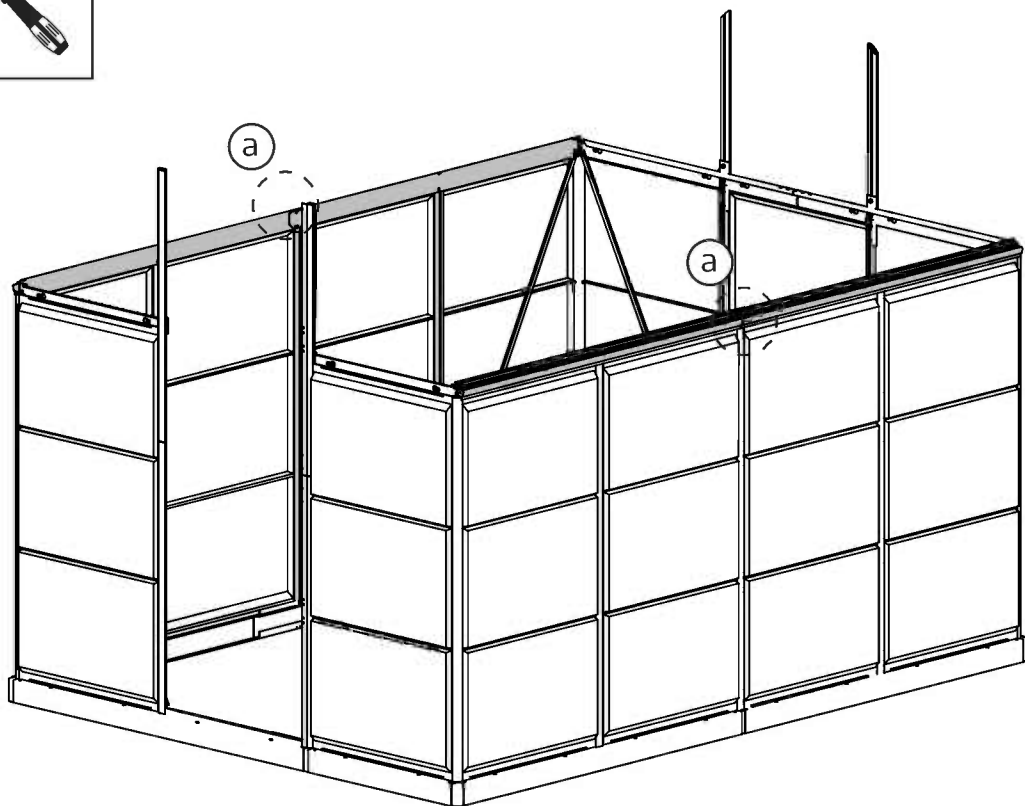
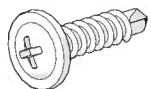

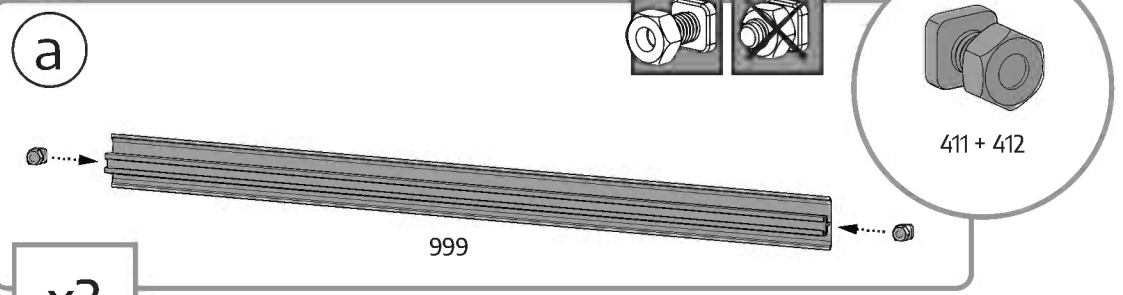
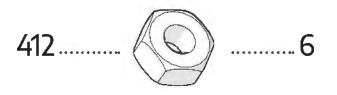
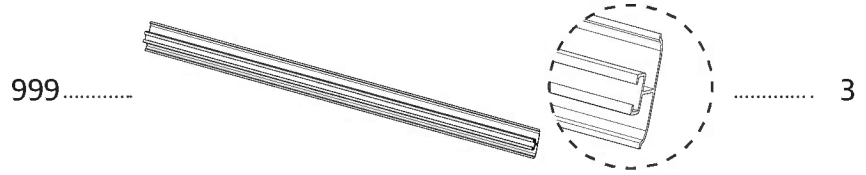

x3

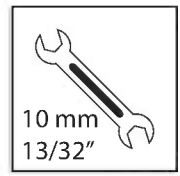
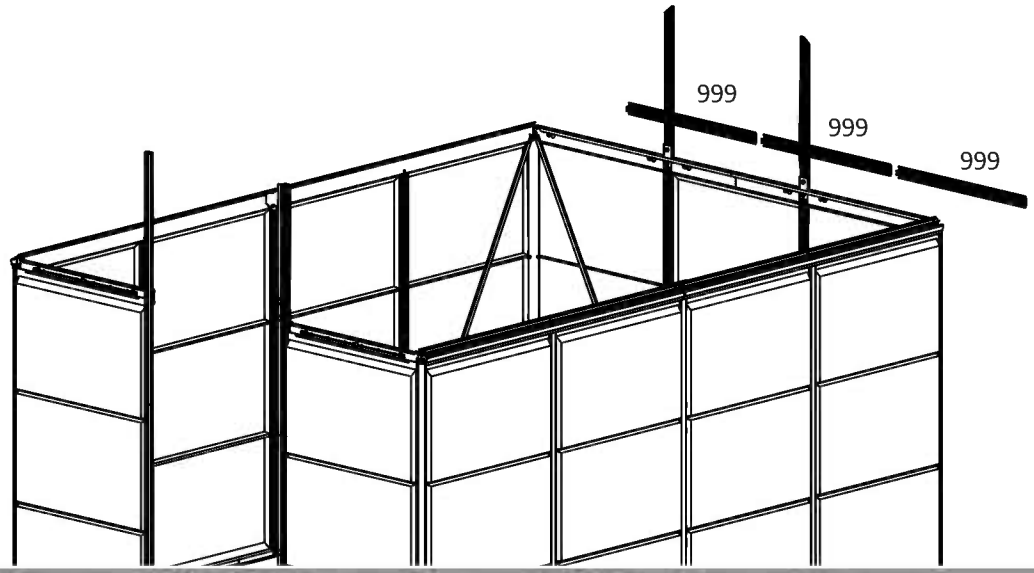
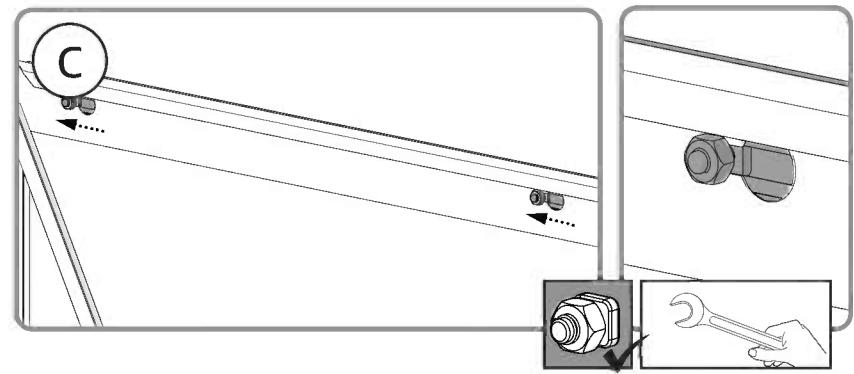
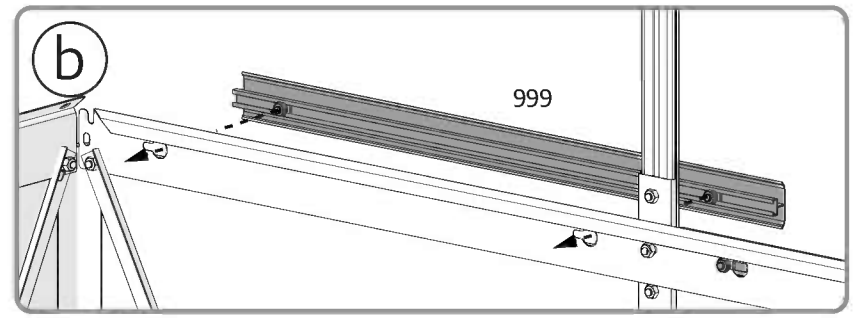

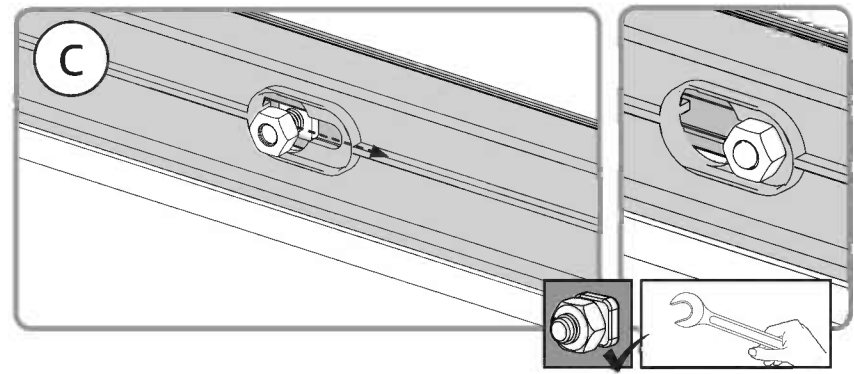
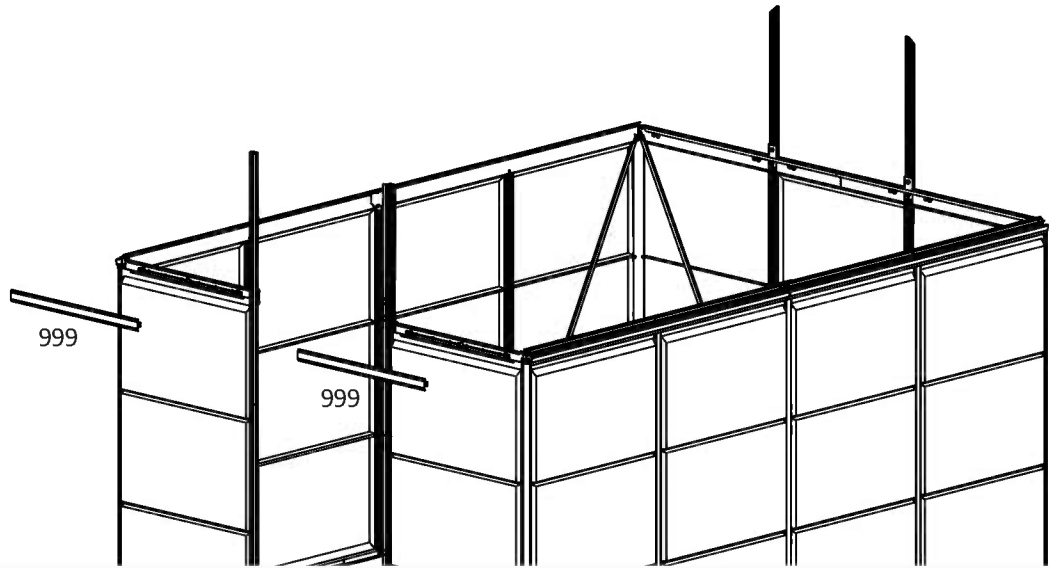
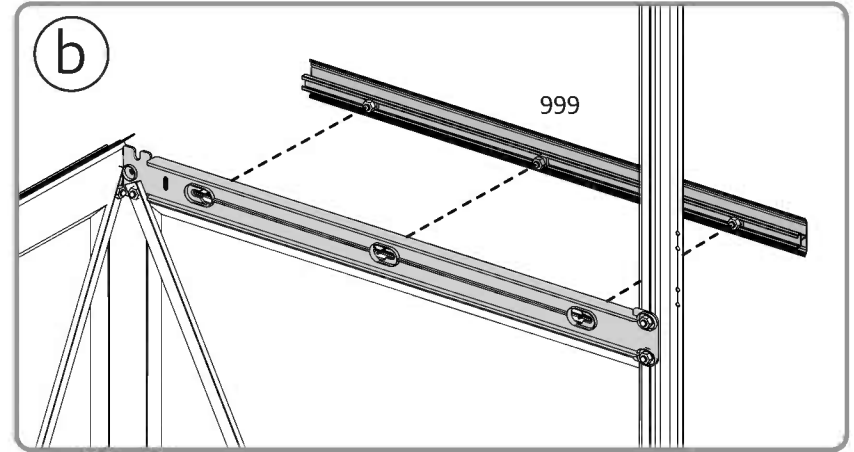
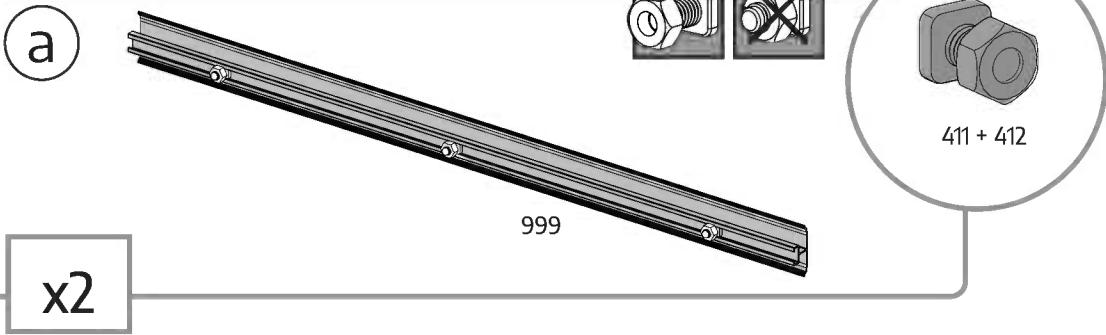
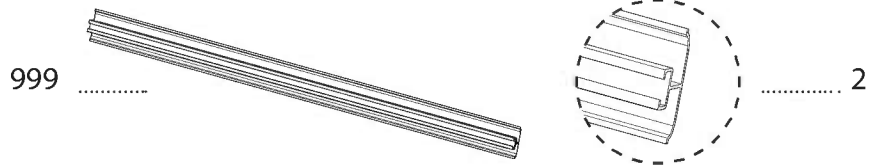



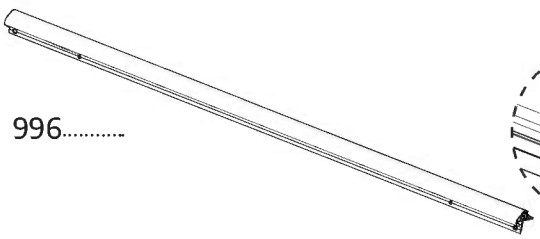
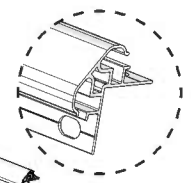

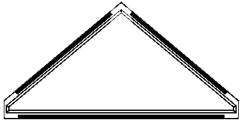
996..... 2 

570  1

411 2

412 2

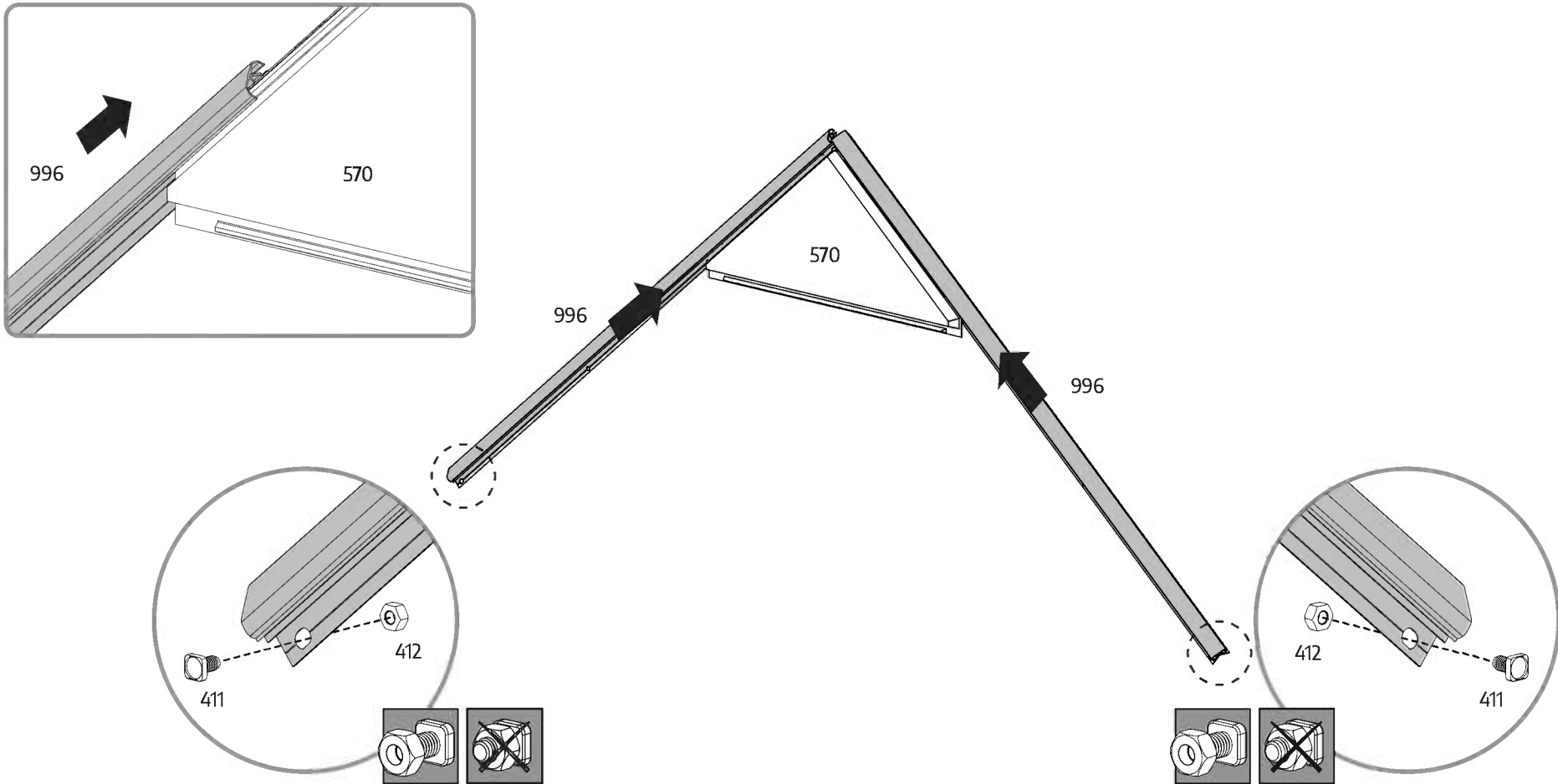

996

570

996

570



996

411

412

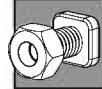

411

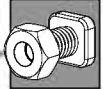
412

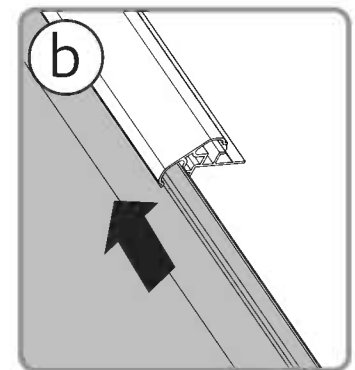
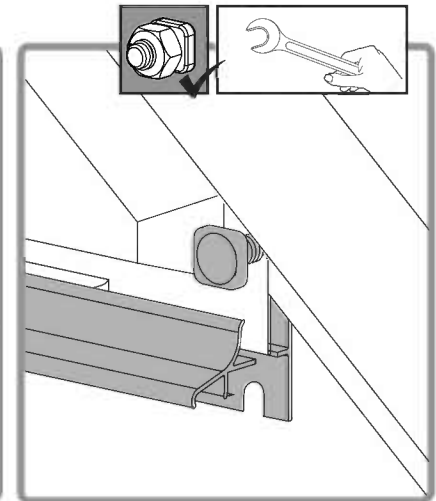
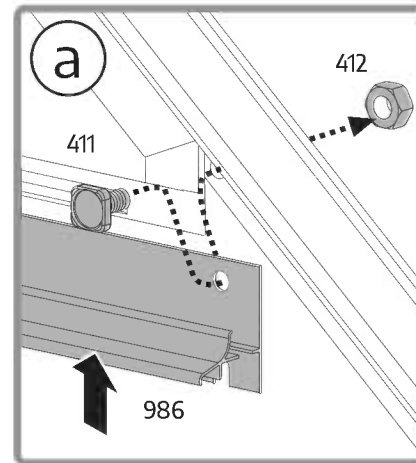
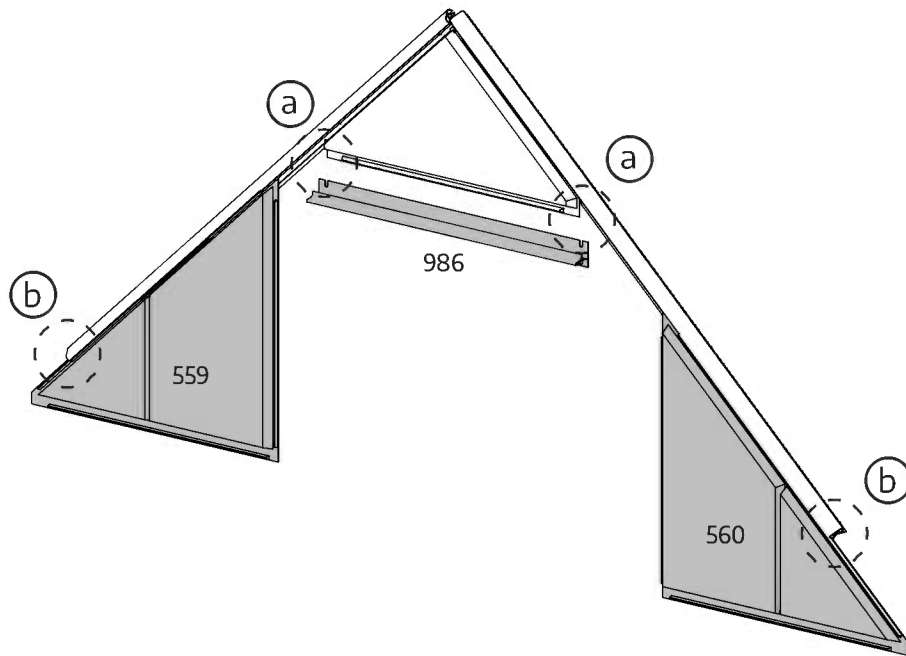
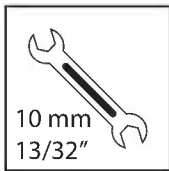
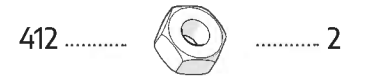
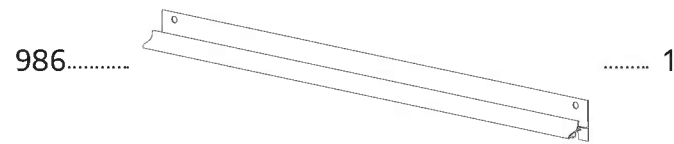
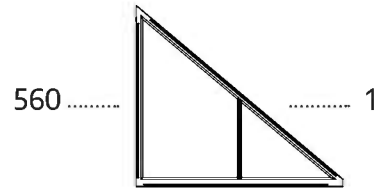
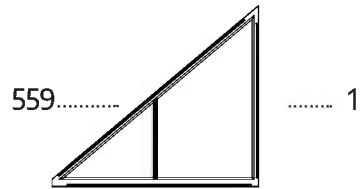





411  4 412  4

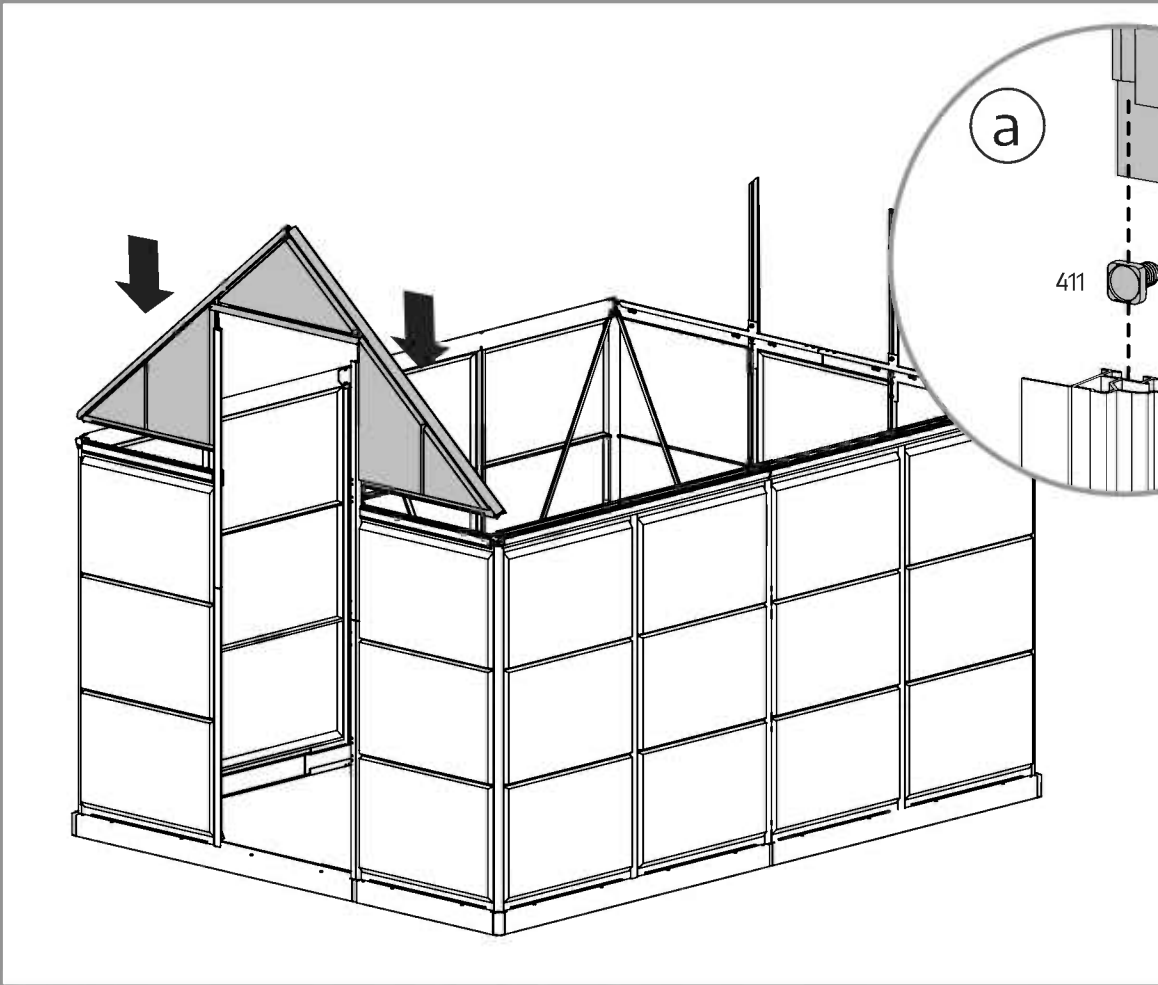

b

412



411

411

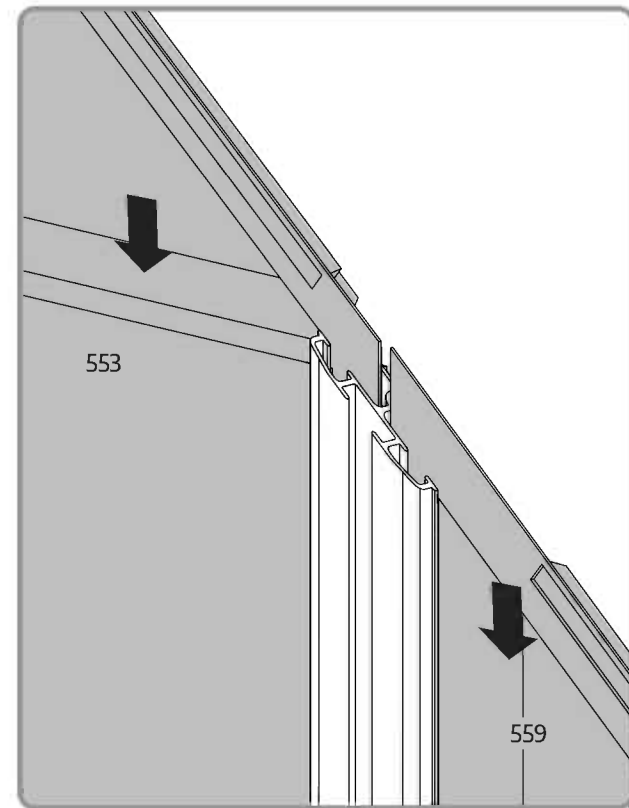
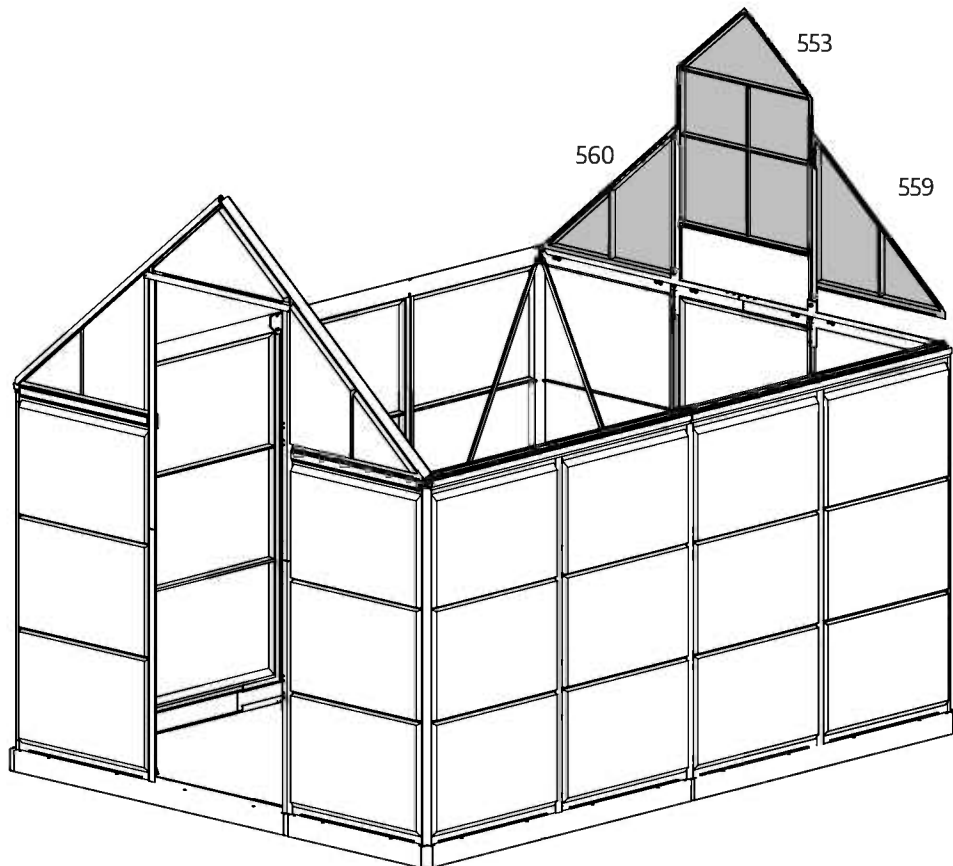
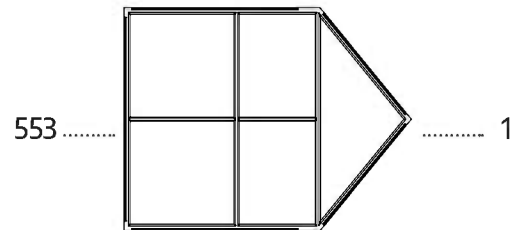
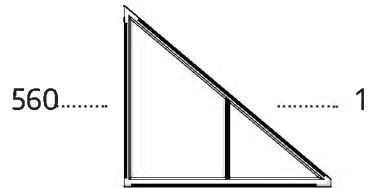
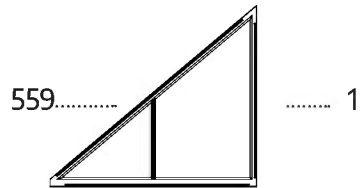
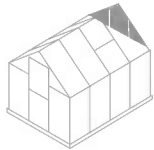
412

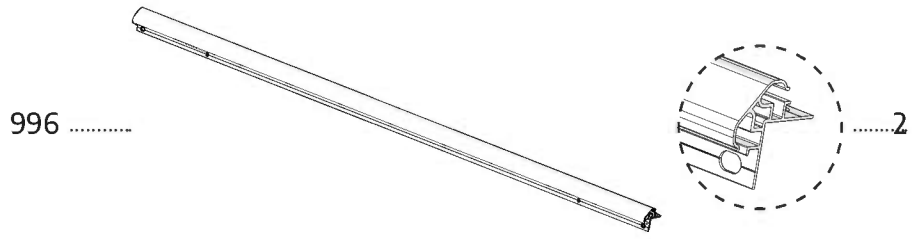



- 411 4
- 412 4

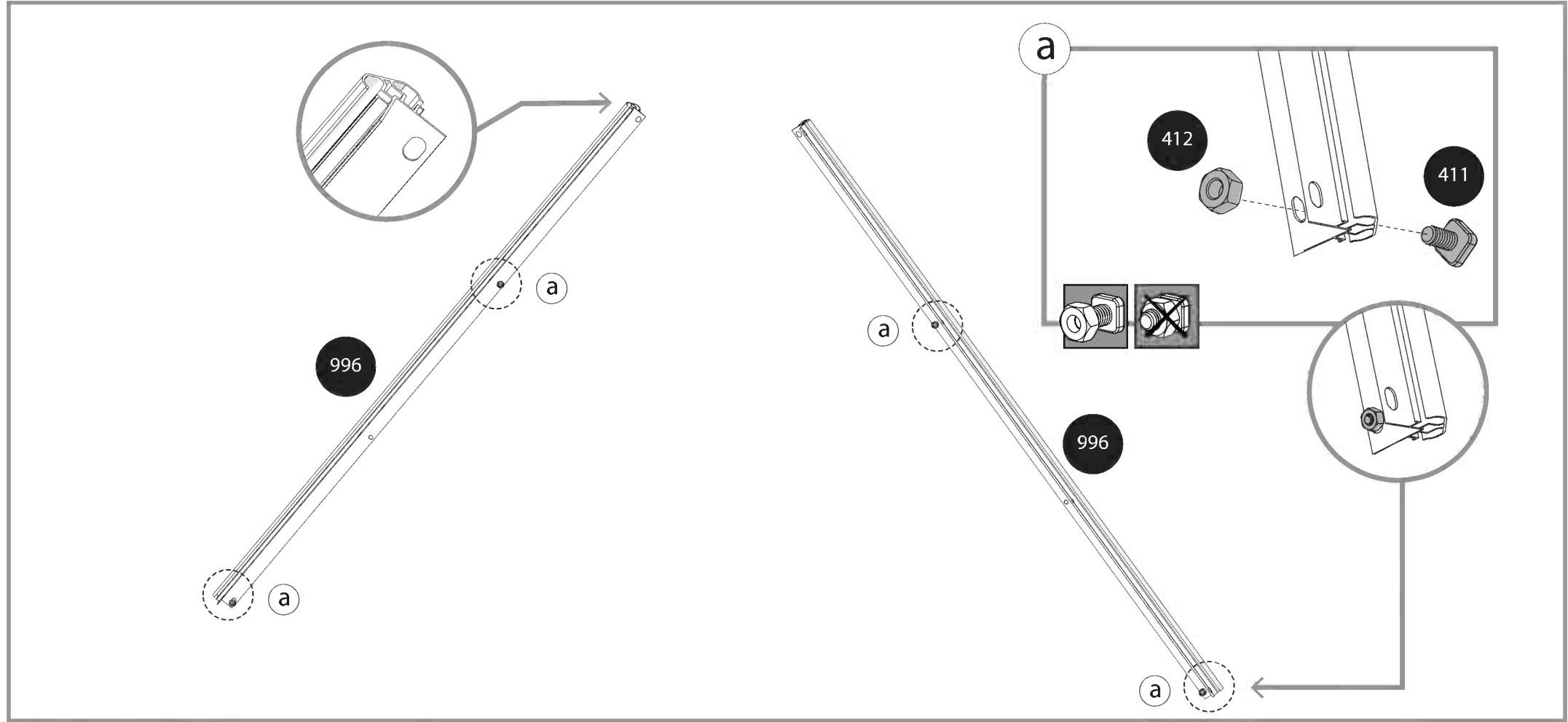

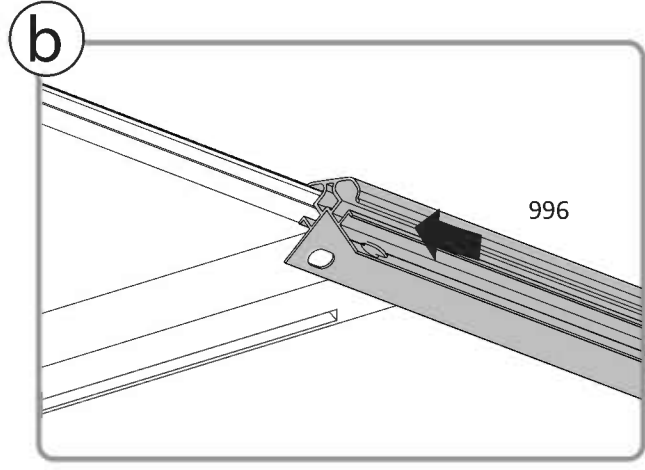
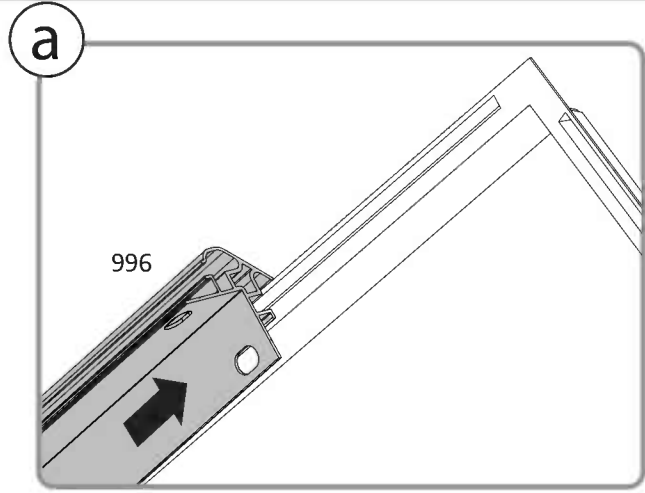
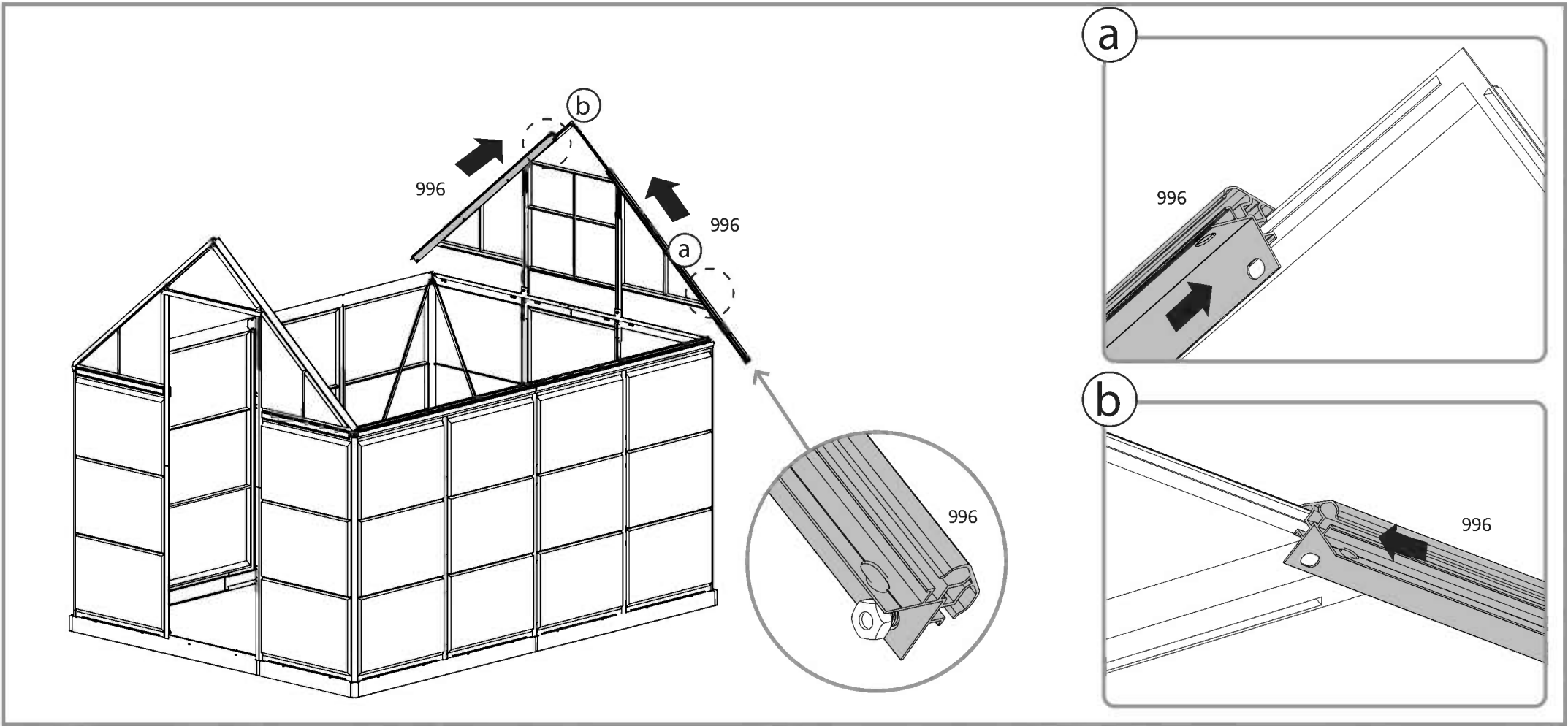
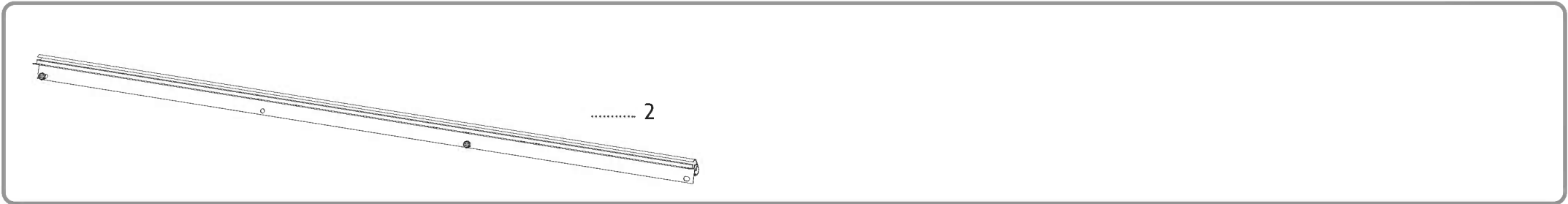



411 2 412 2

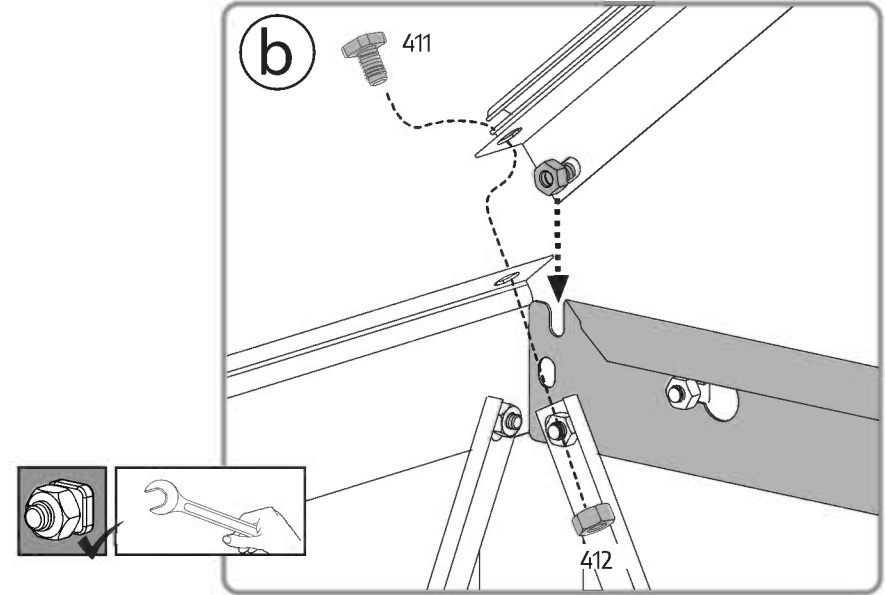
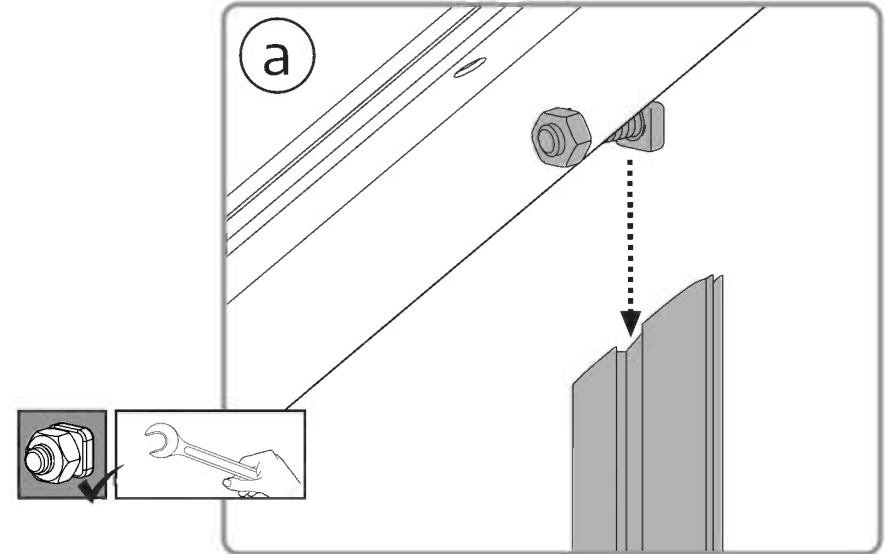
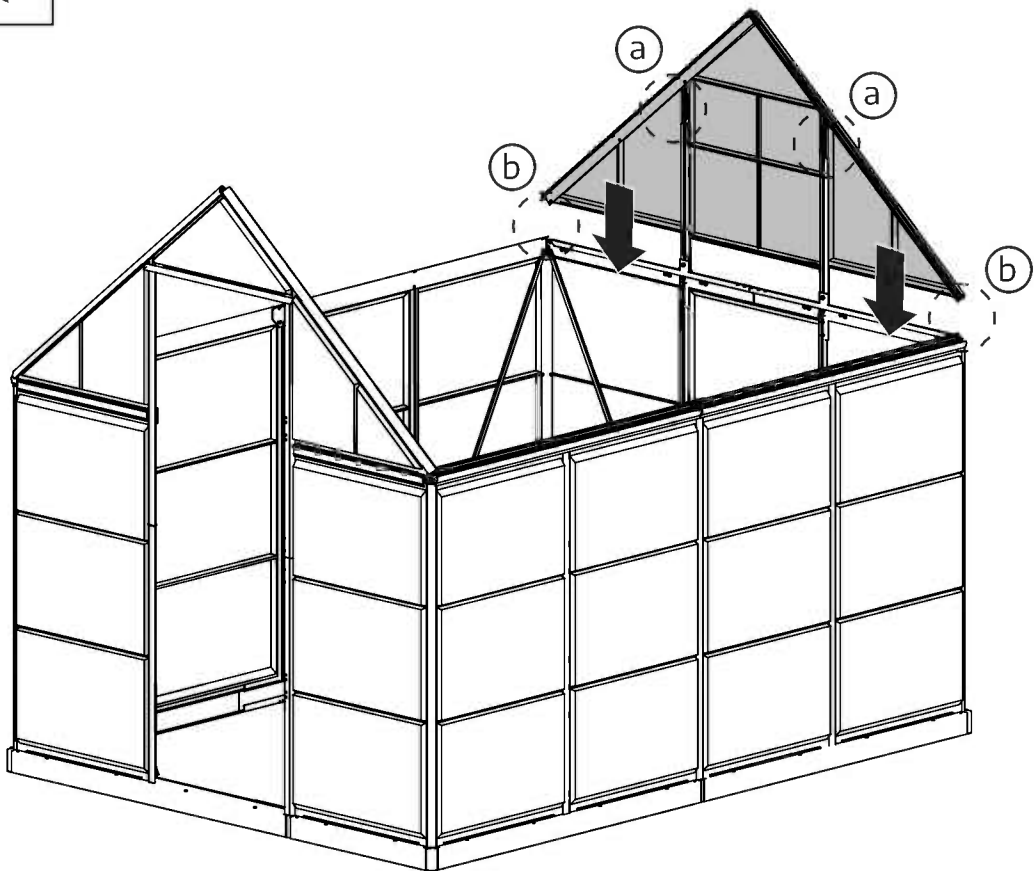

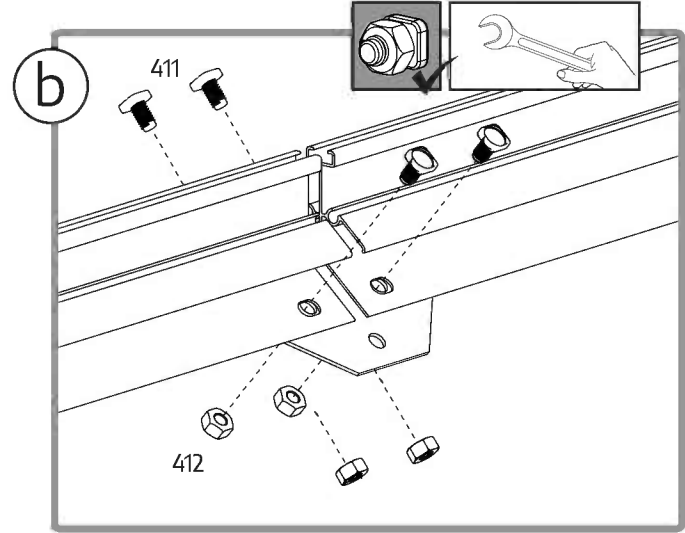
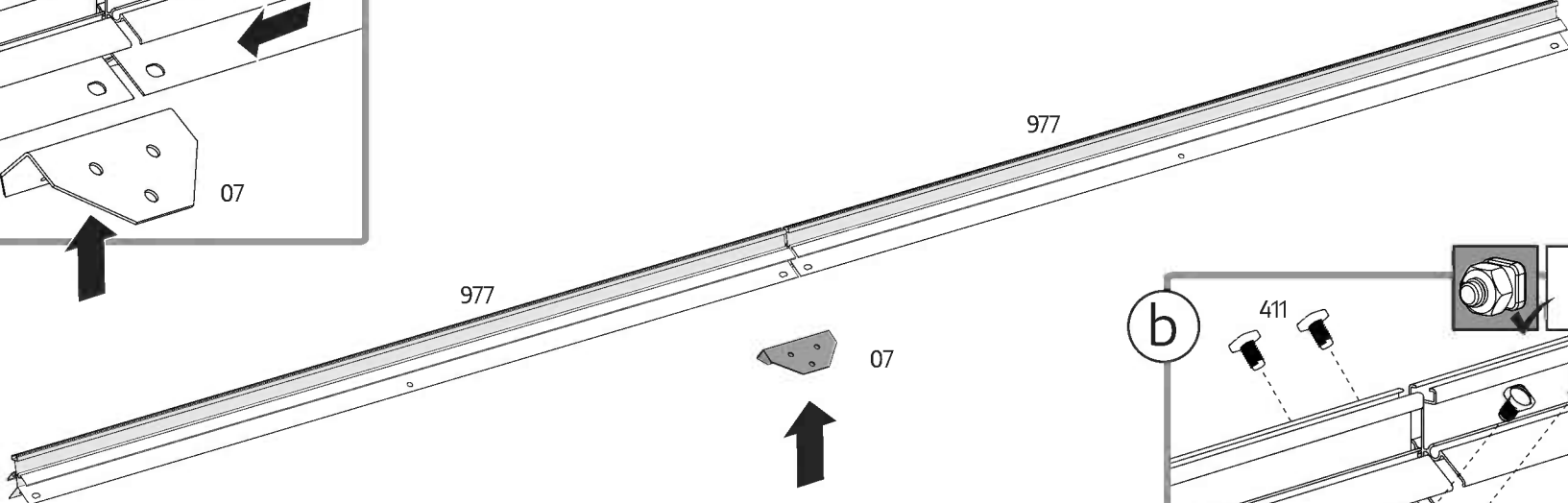
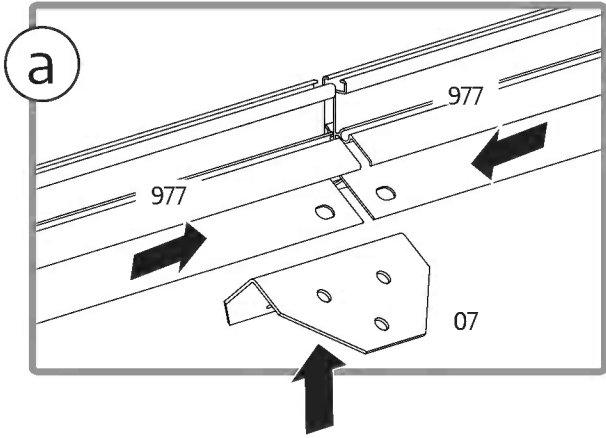
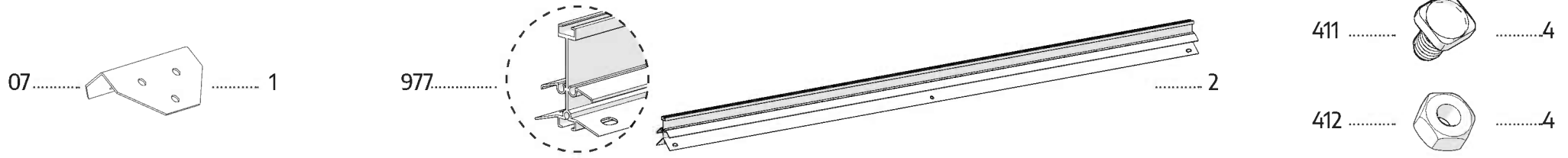

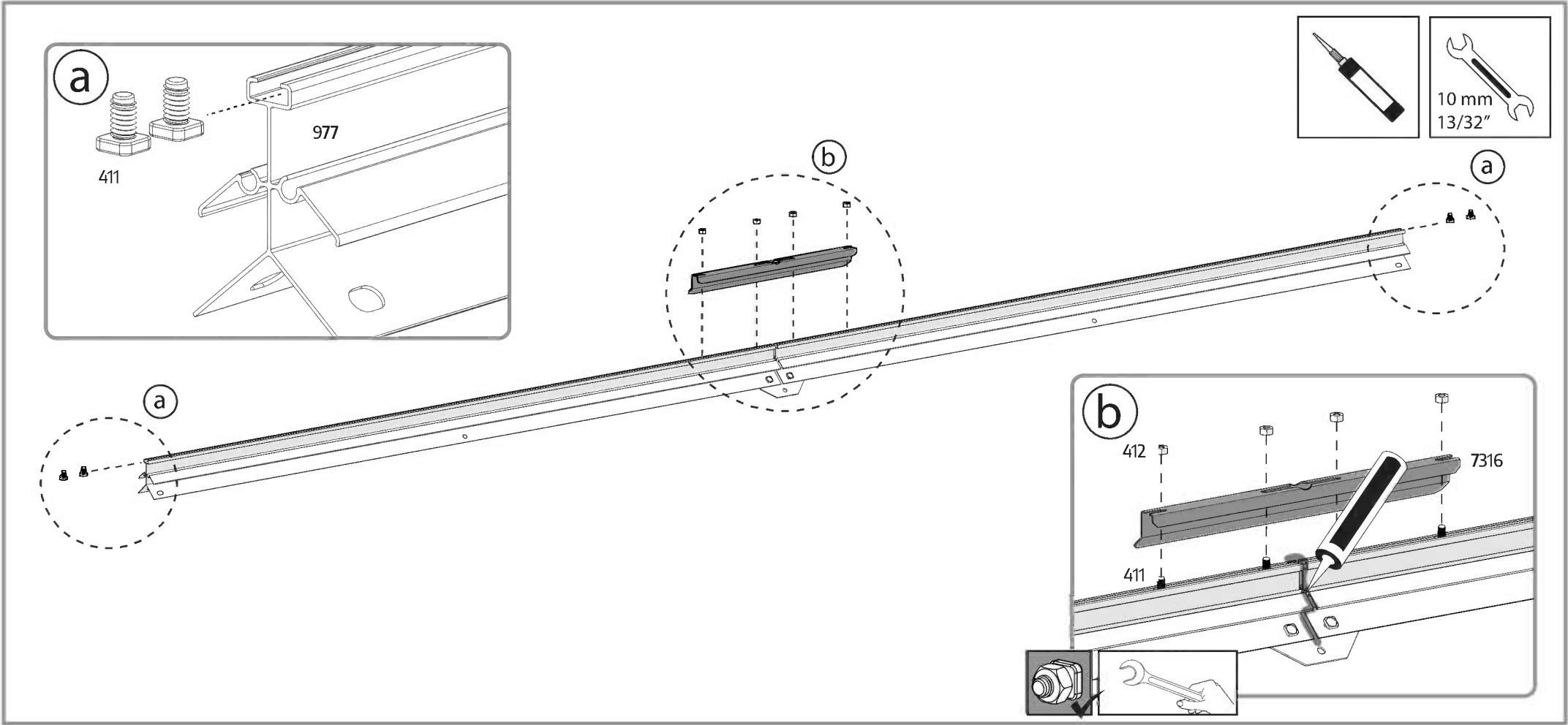
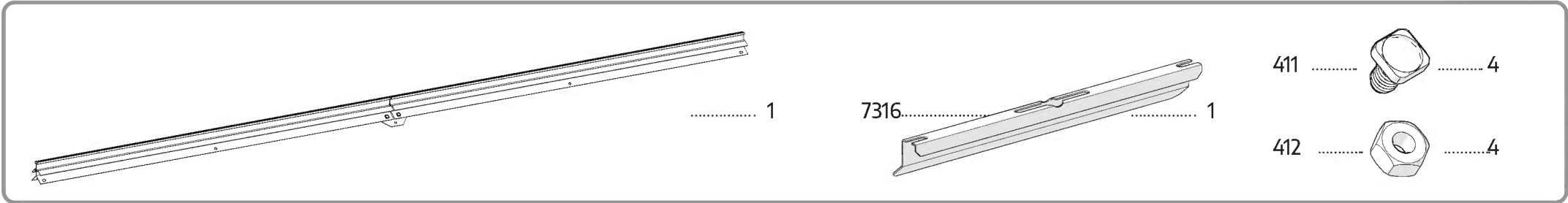



411  6 412  6

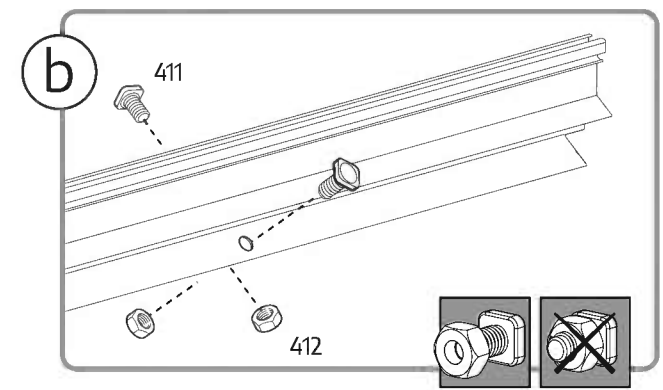
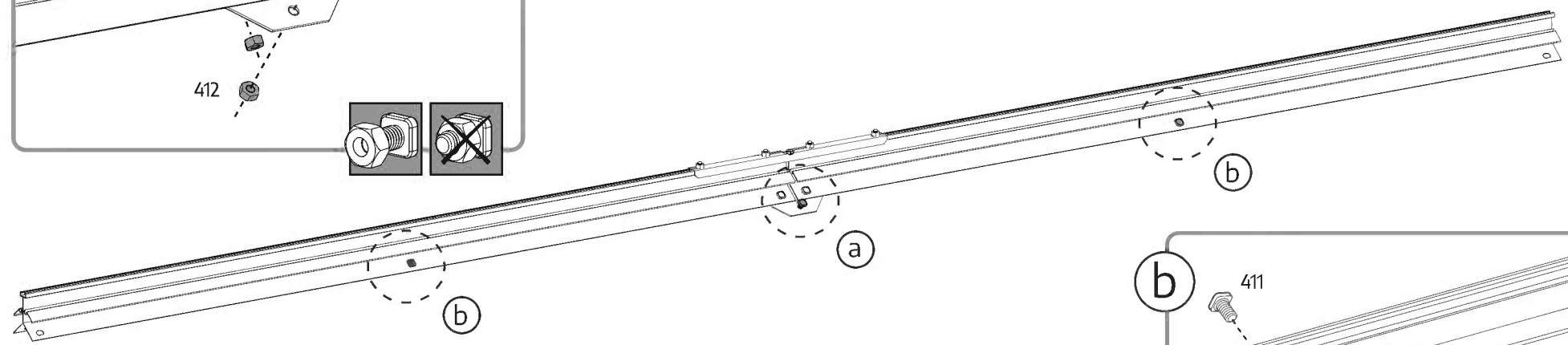
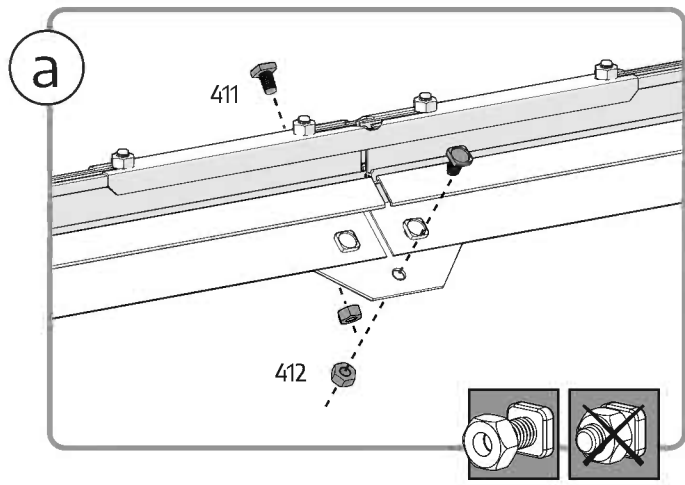



Decide on the window's location before assembly.
Window can be installed in one of the indicated options.

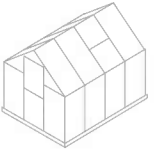

- EN** Windows Location
- GR** Fenster Standort
- FR** Fenêtre Emplacement
- SP** Ventana Ubicación

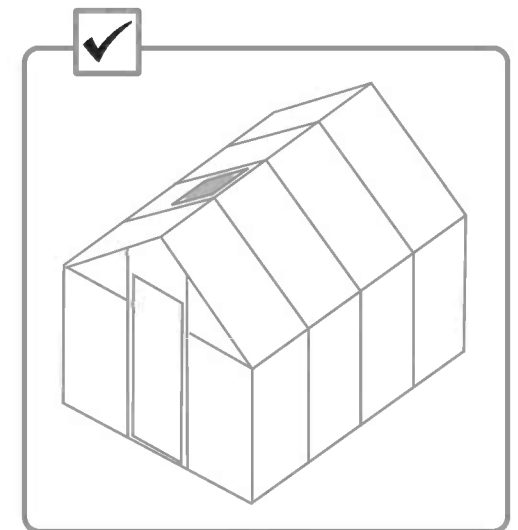
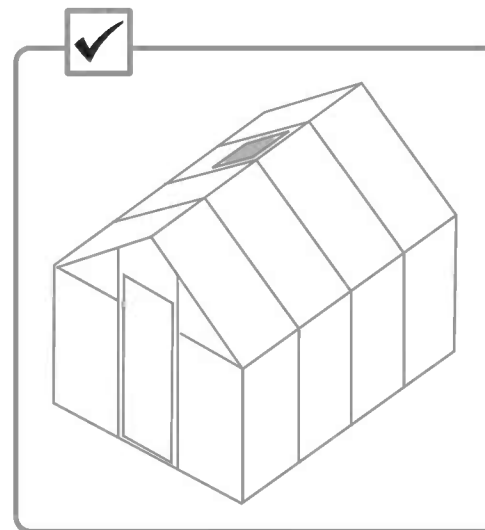
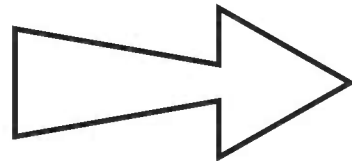
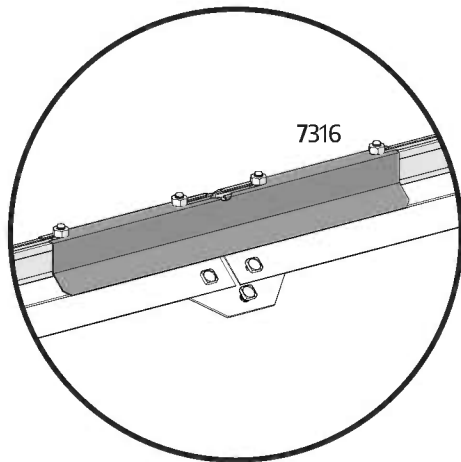
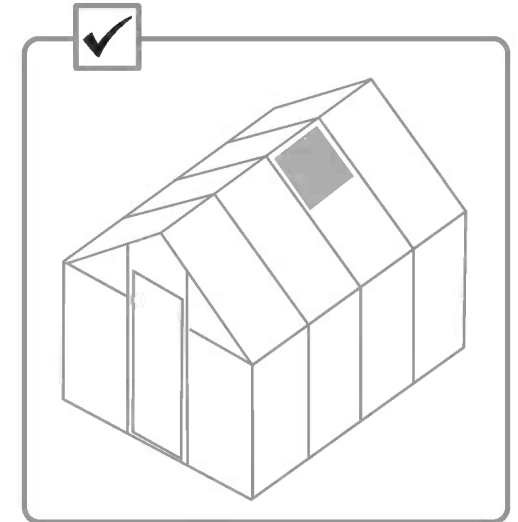
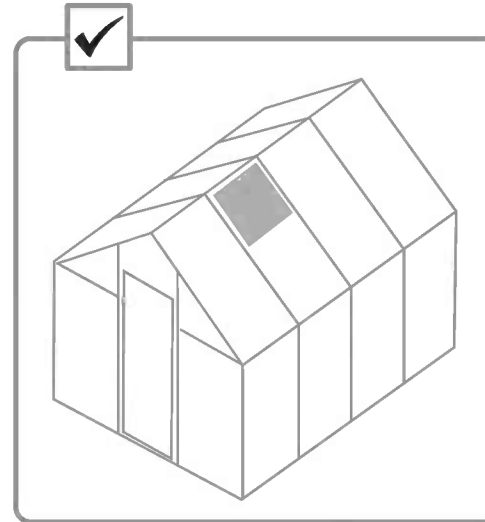
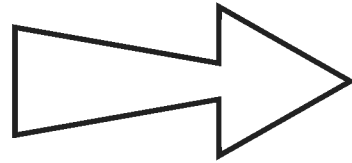
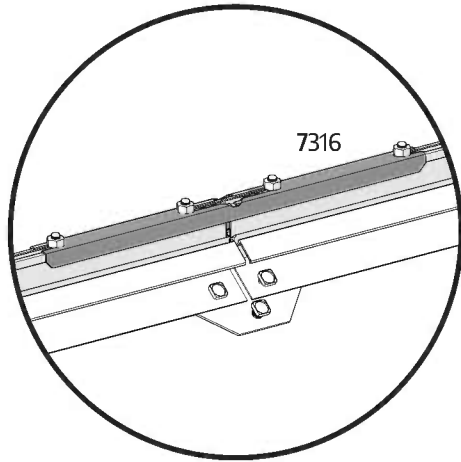



Once the window location is chosen, please turn part #7316 into the correct position accordingly.

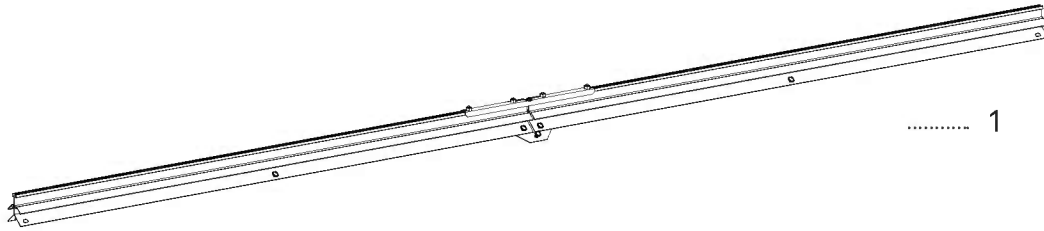

..... 1



411..... 4



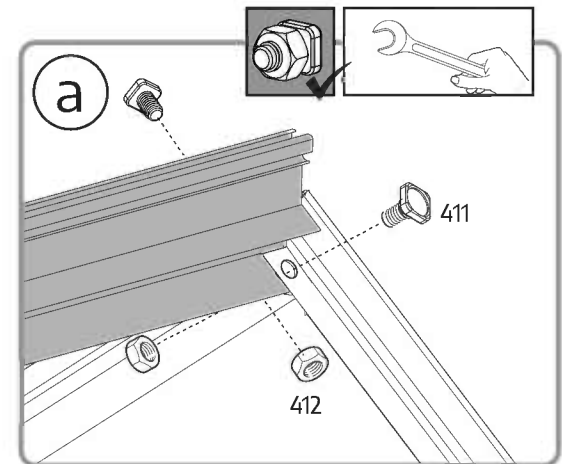
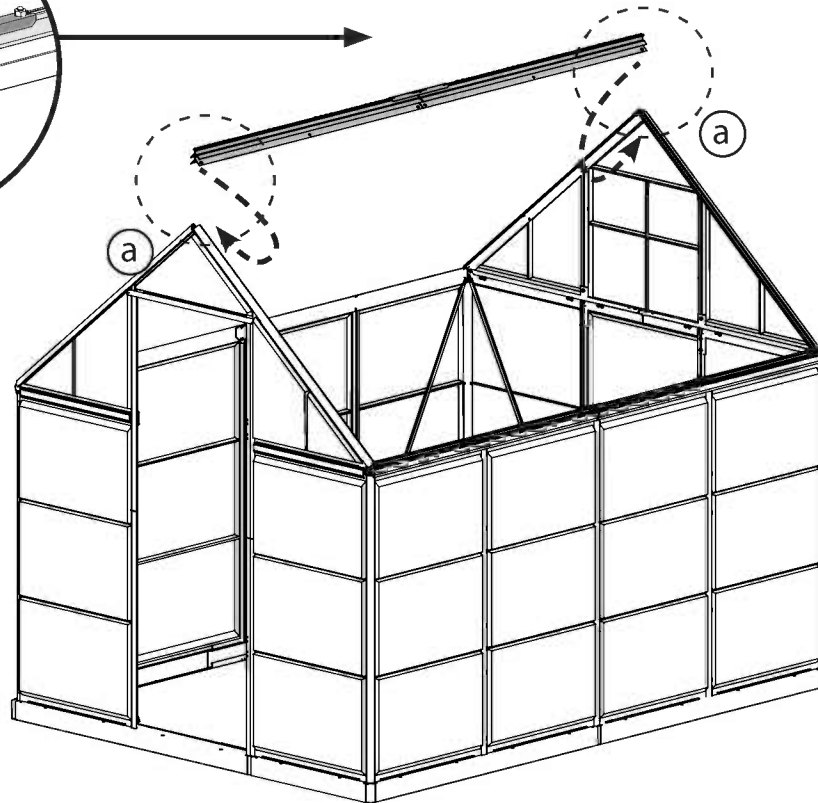
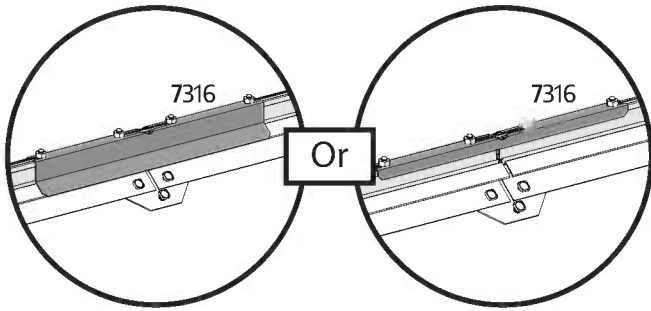

412..... 4

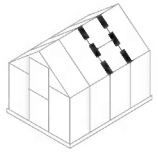

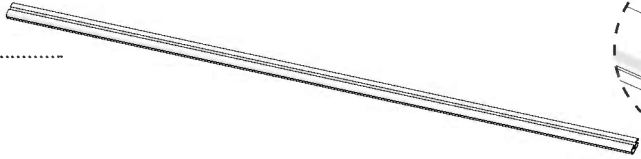
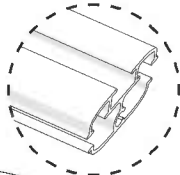

993..........2 

8710..........2

411..... 4

412.....4

a

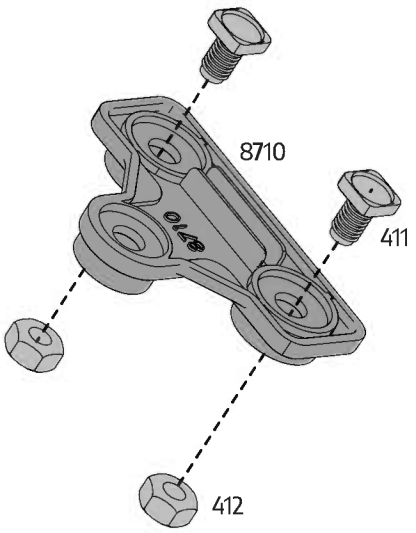

8710

411

412

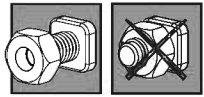

b

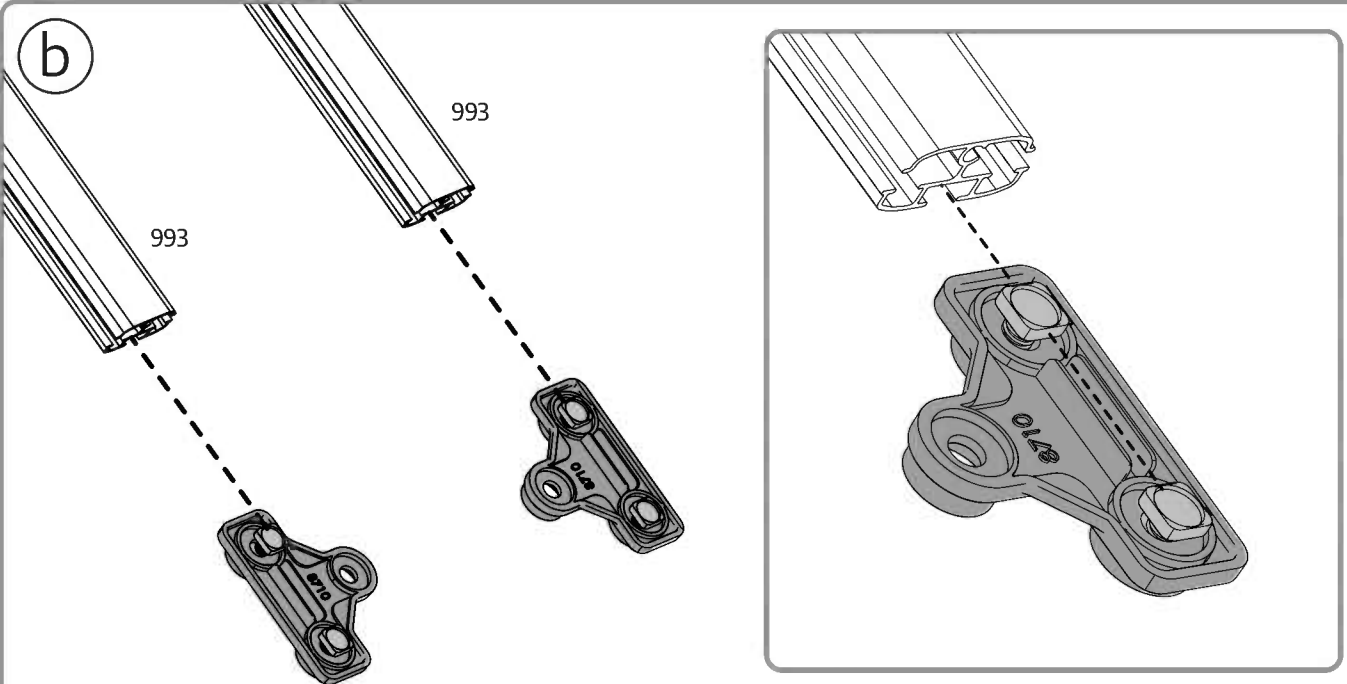

993

993

8710

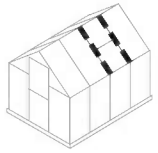

..... 2



411 2



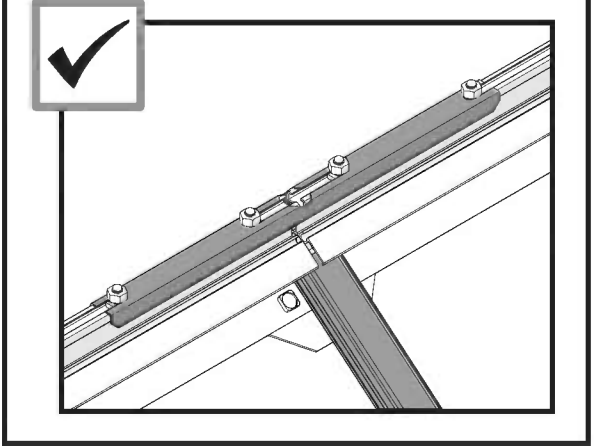
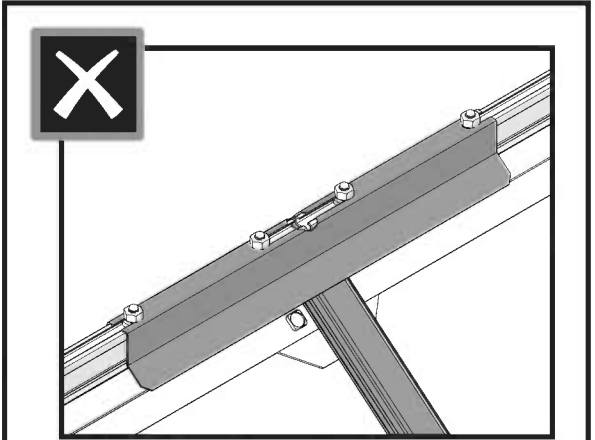
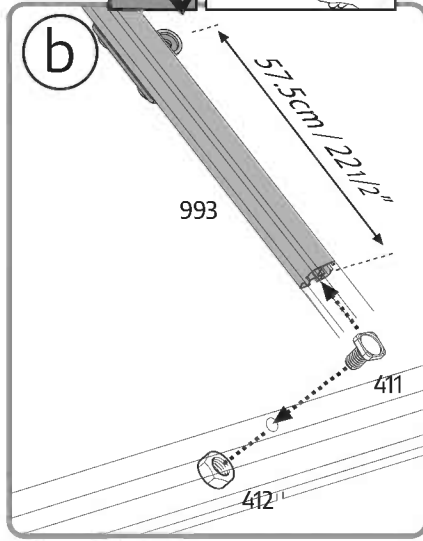
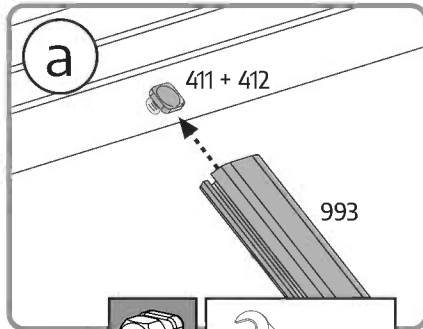
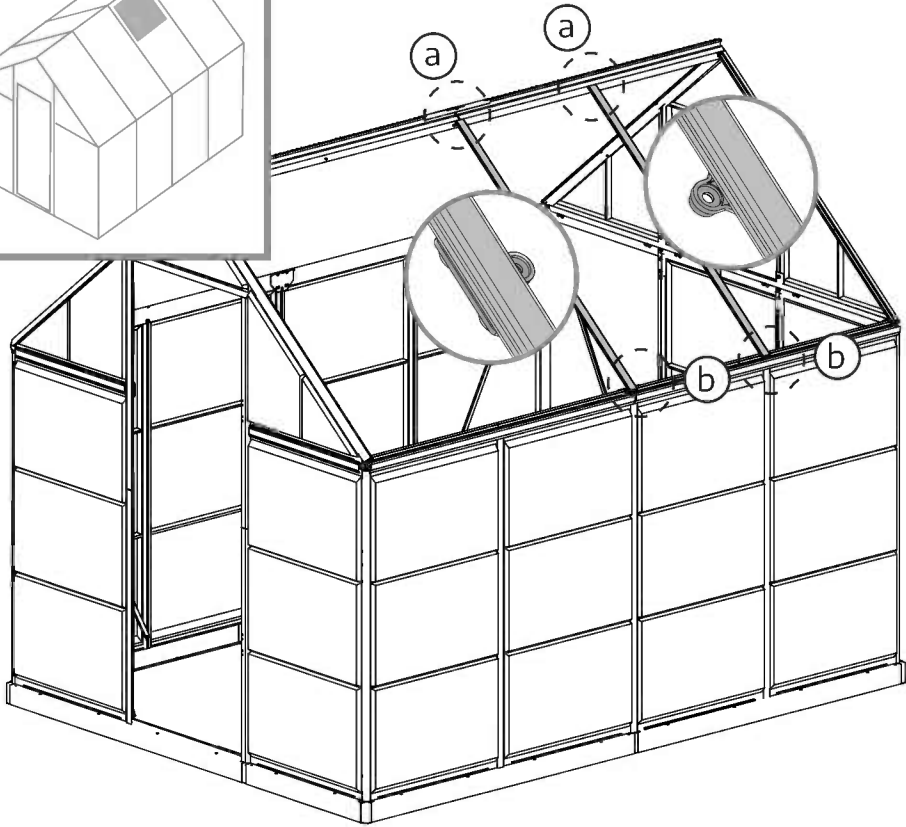
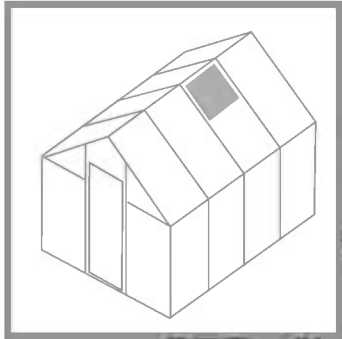

412 2



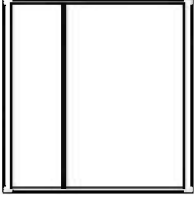

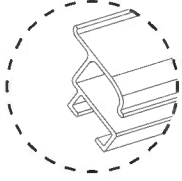
7010.....  1

990.....  1

411.....  3

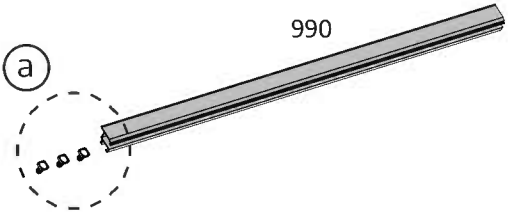
a  990

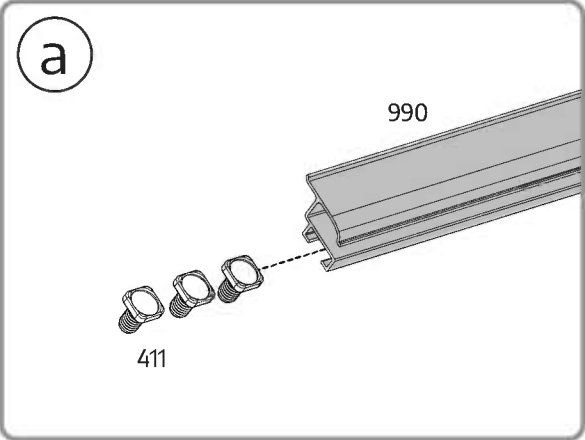
a  990
411

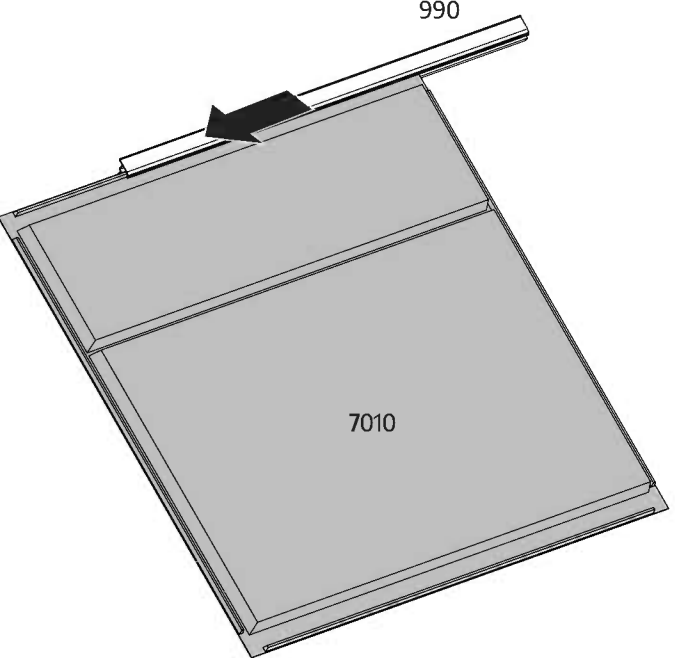
 990
7010

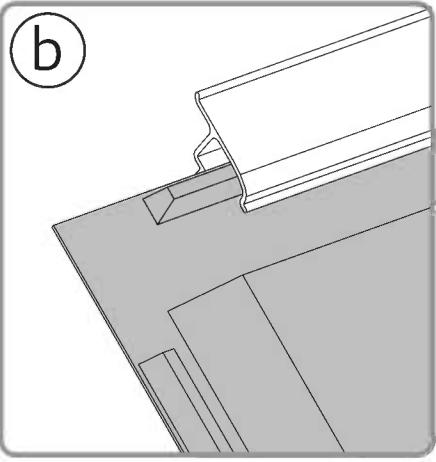
b 

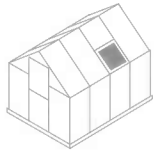

7010 + 990

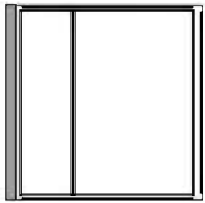

.....1

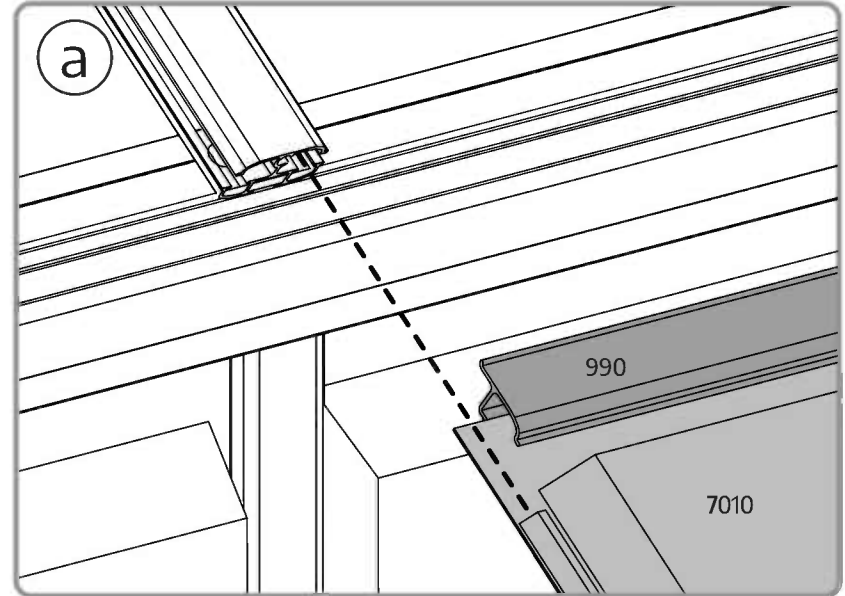
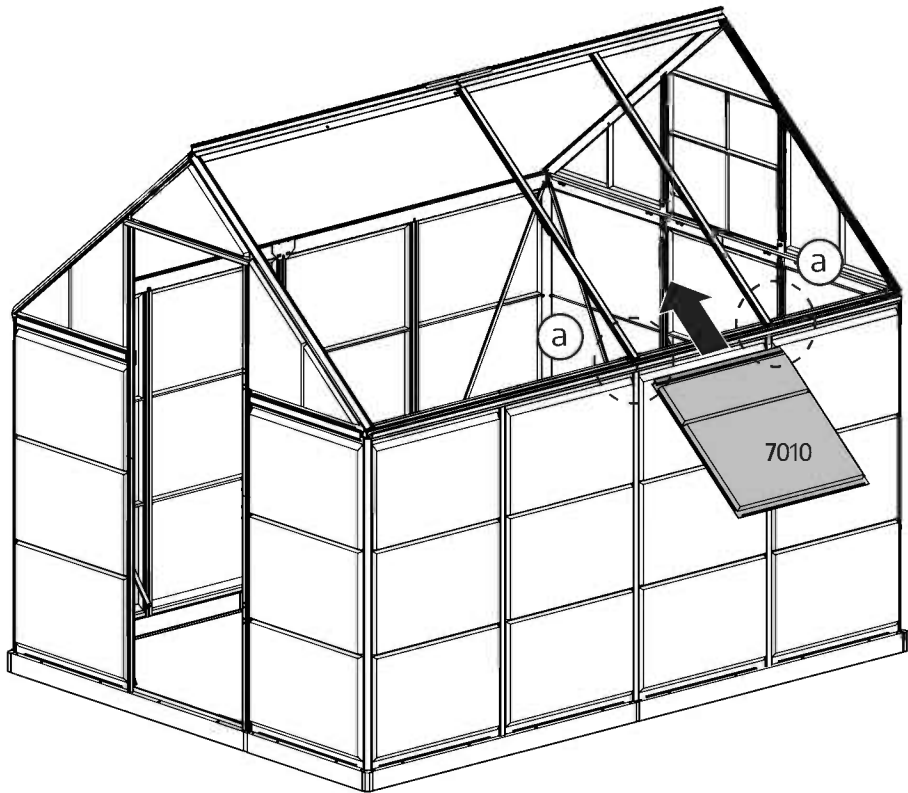

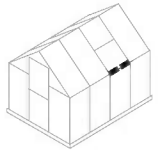

981.....

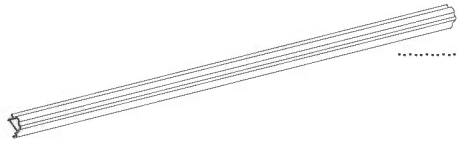

.....1

412.....



.....2

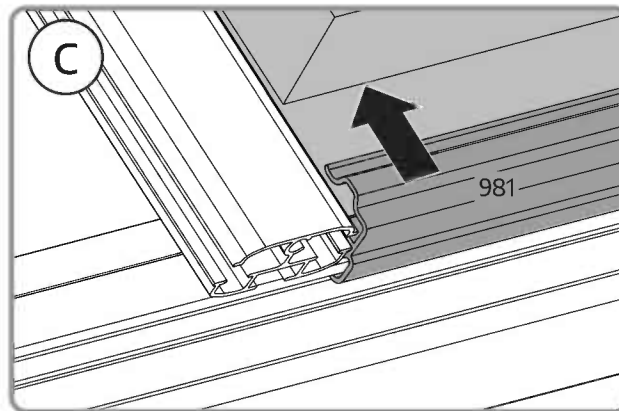
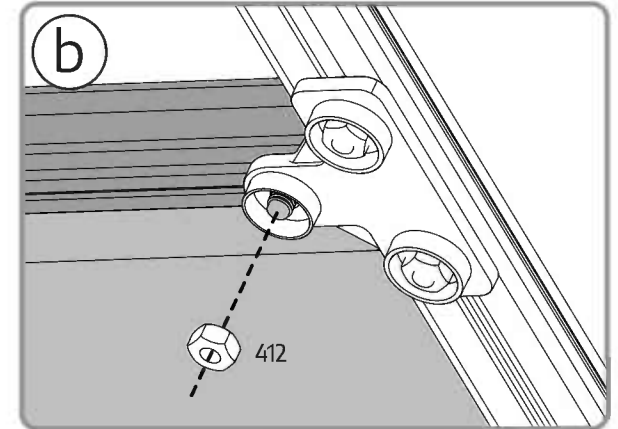
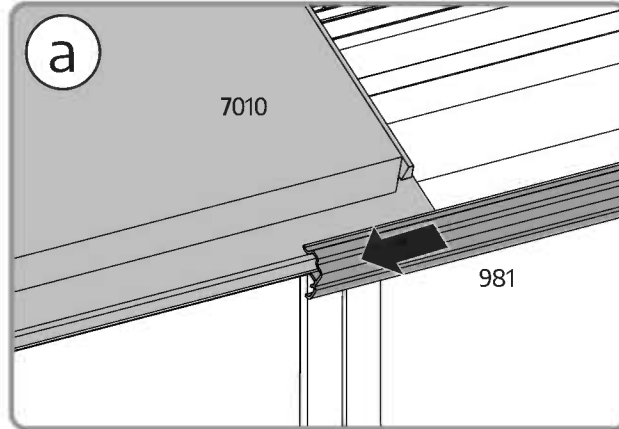
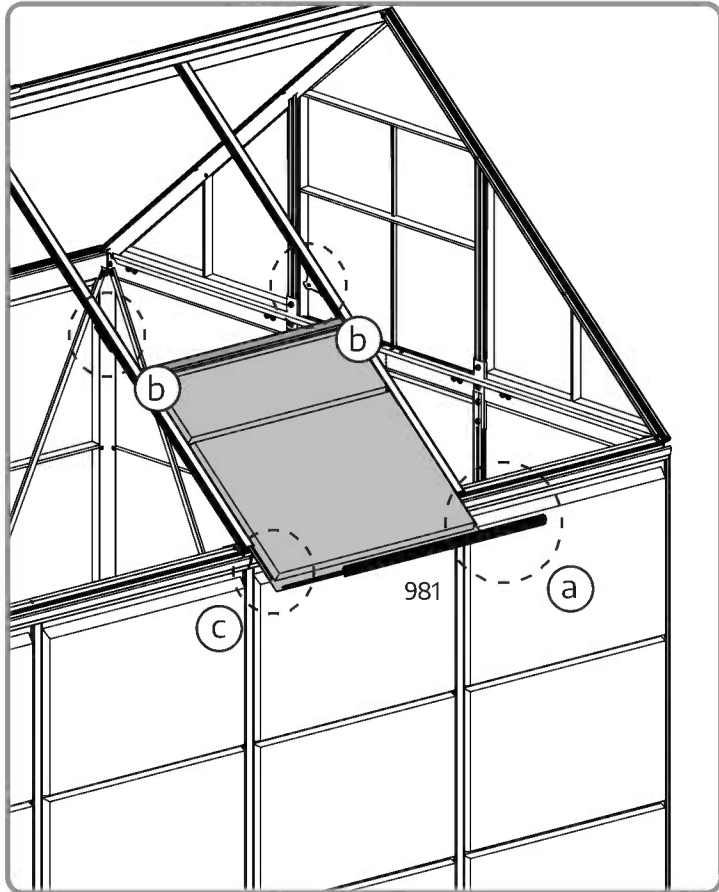

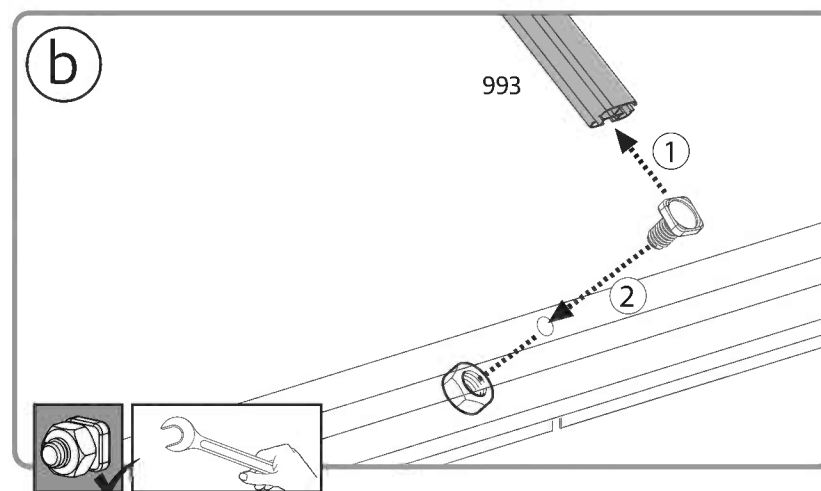
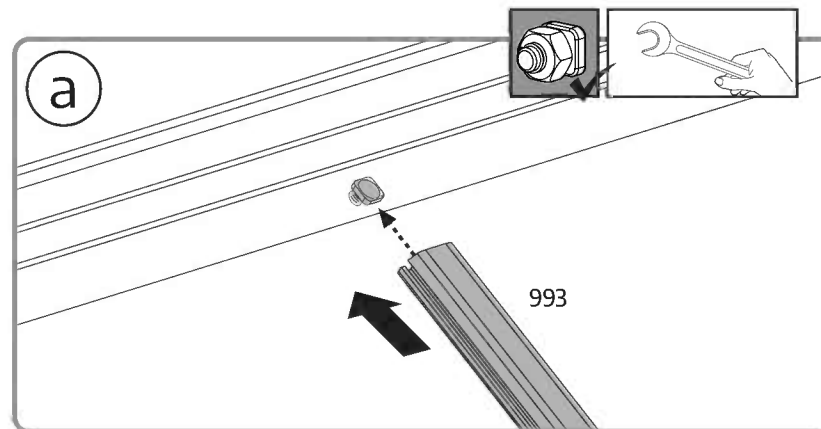
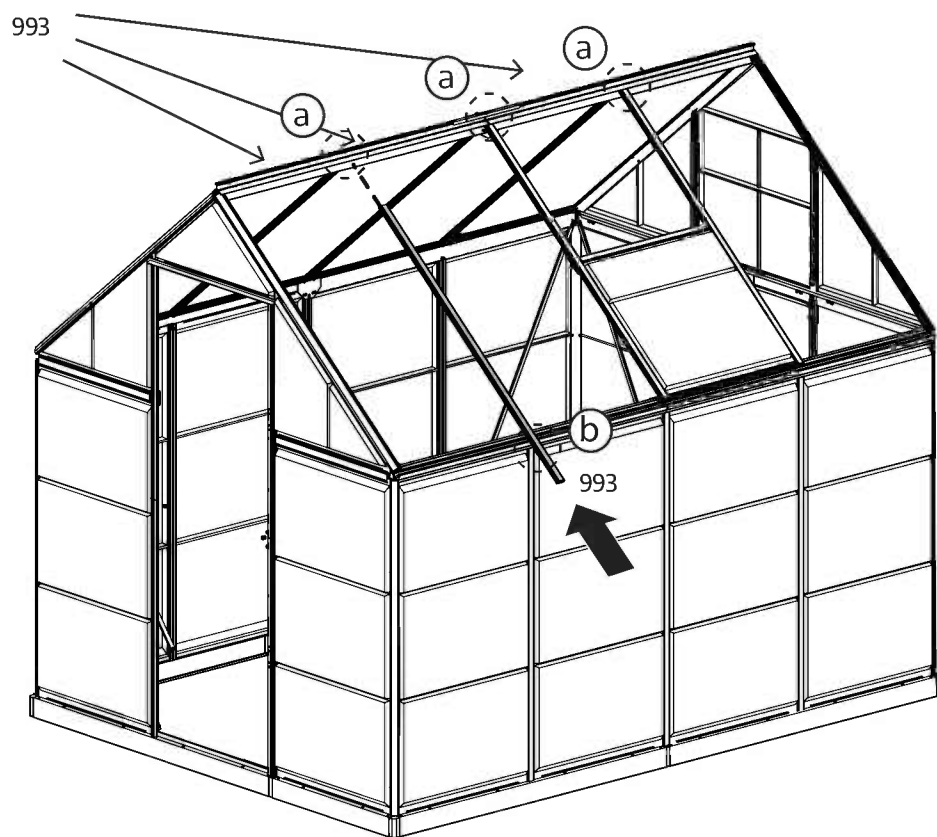
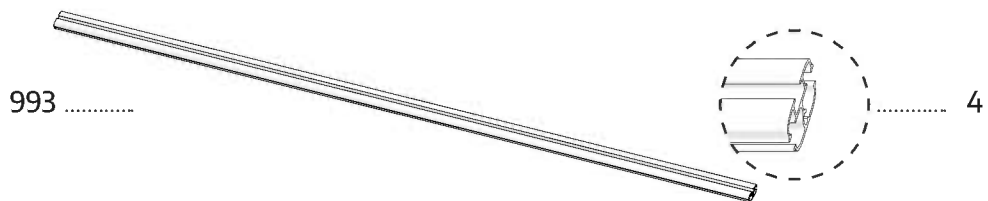
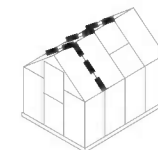

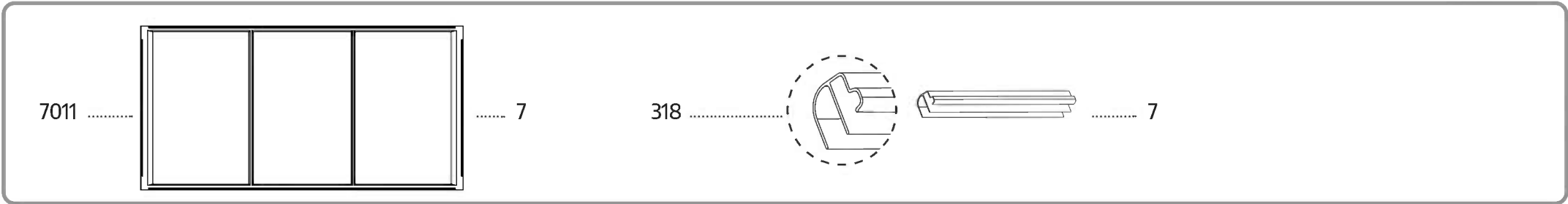
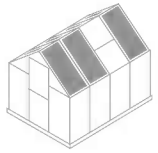

x7

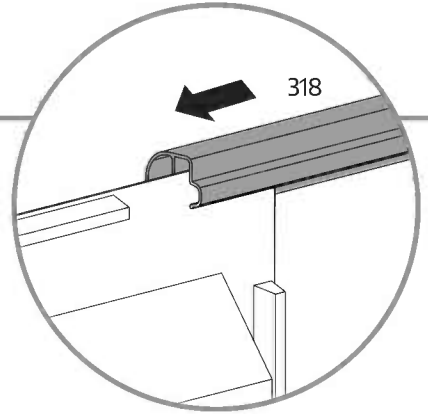
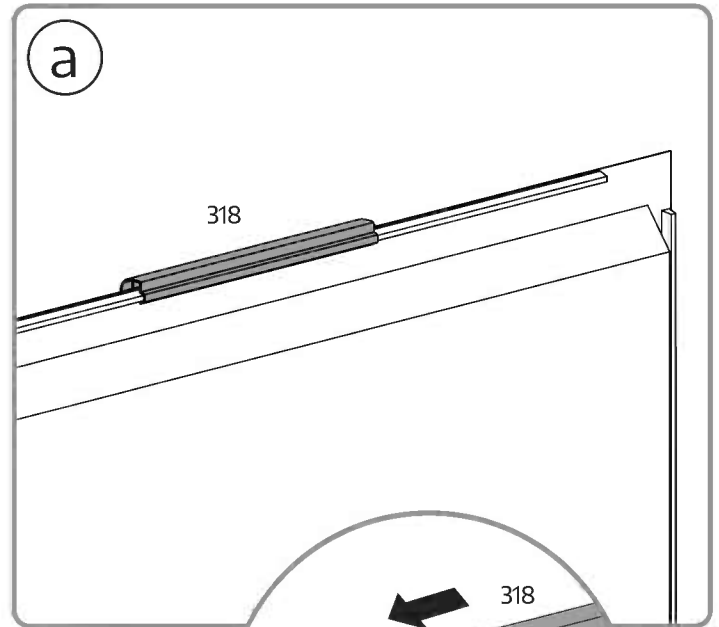
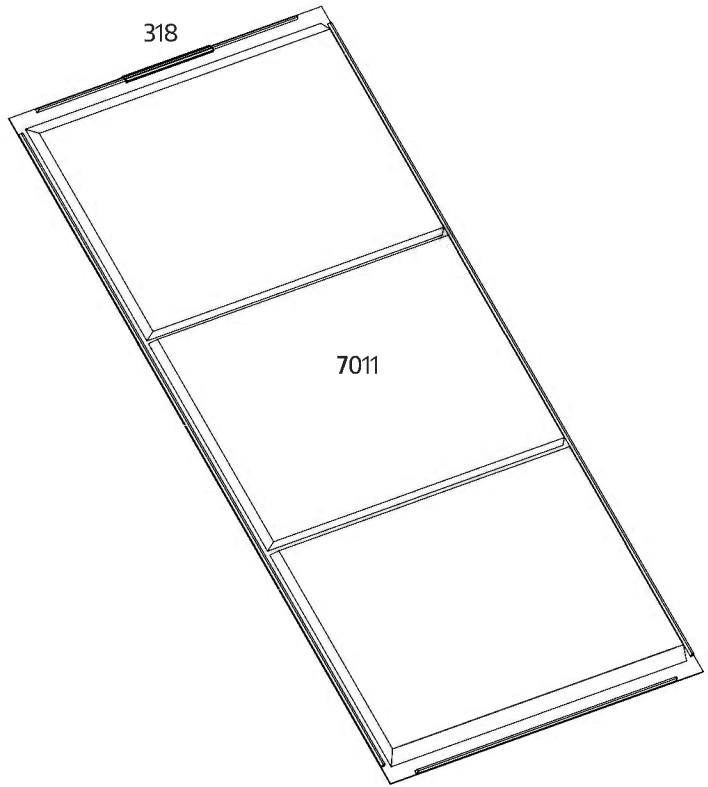

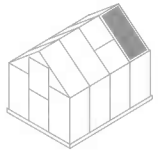

7011 + 318

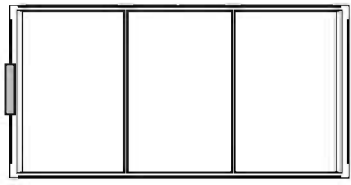

..... 1

981.....

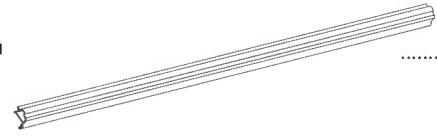

..... 1

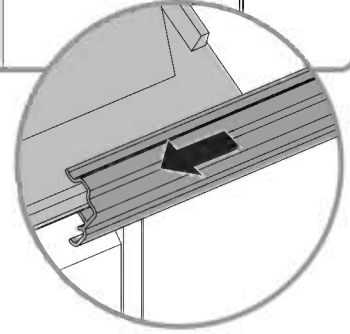
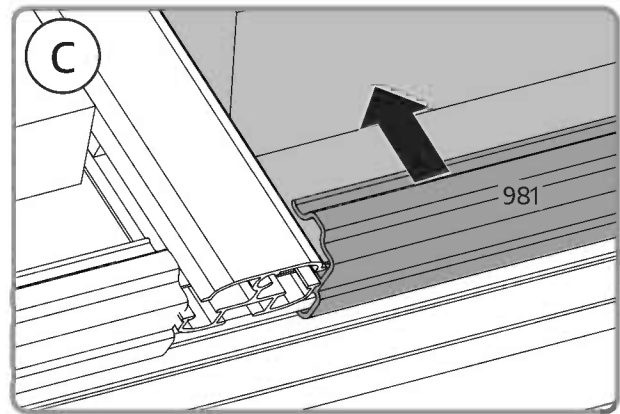
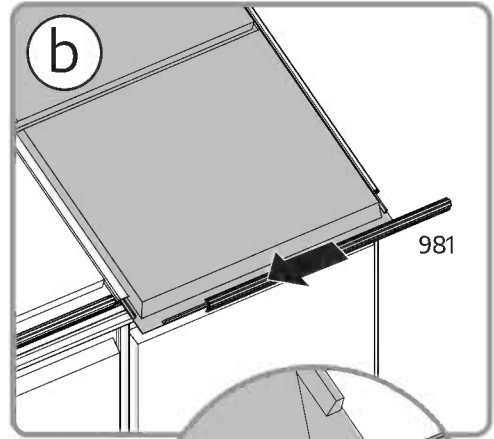
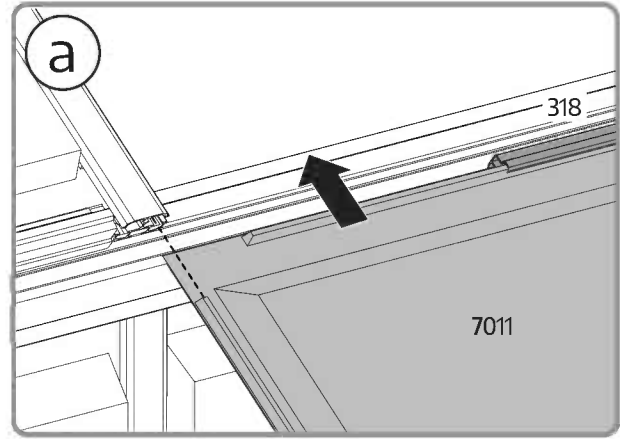
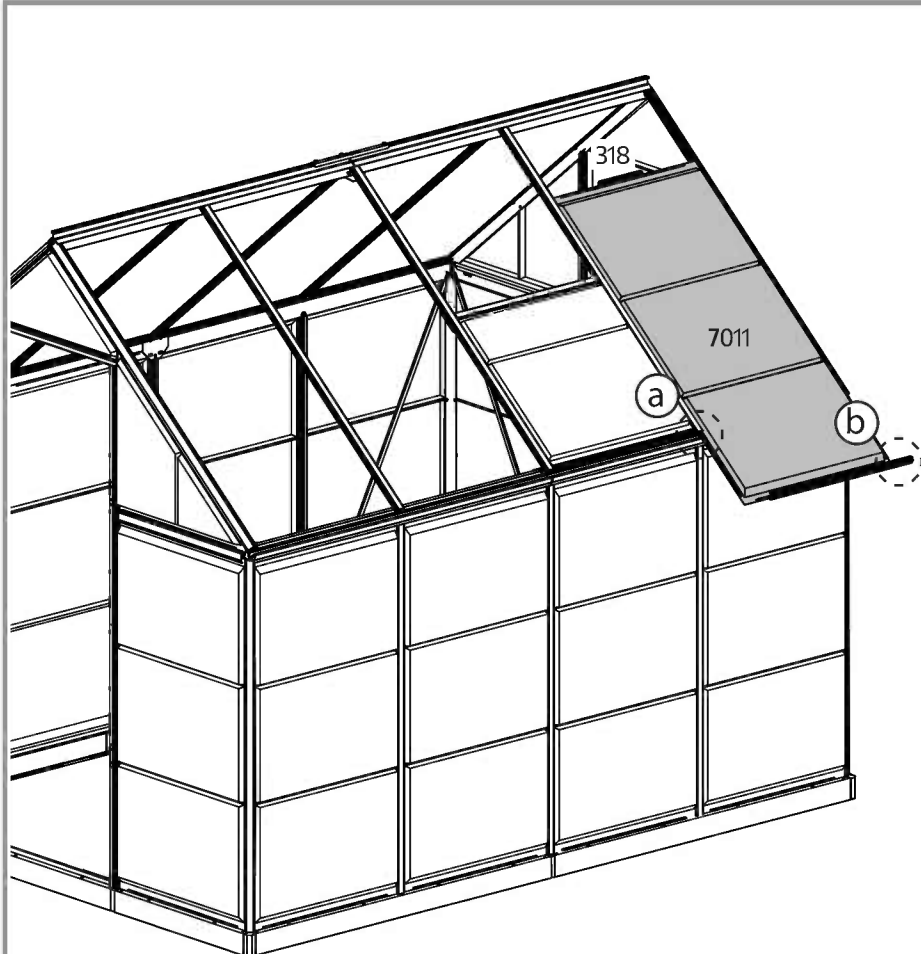

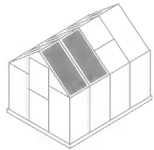

7011 + 318

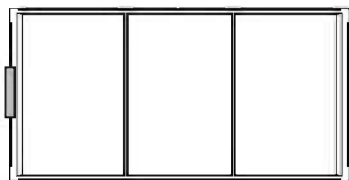

.....6

981

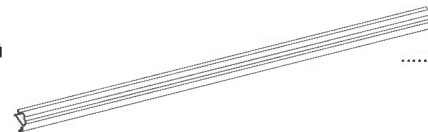

.....6

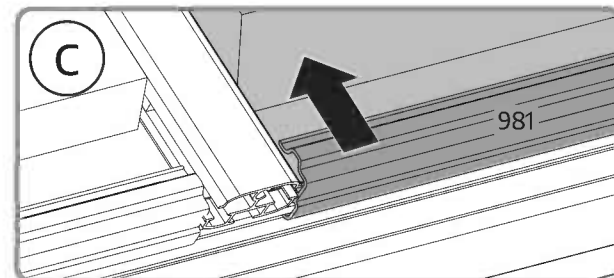
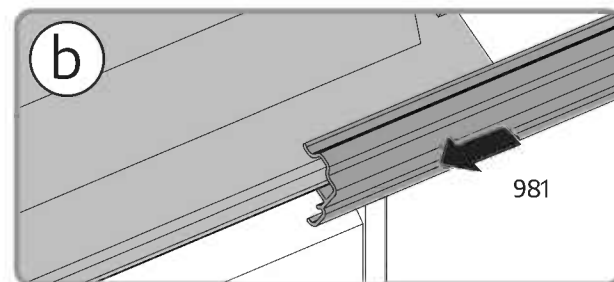
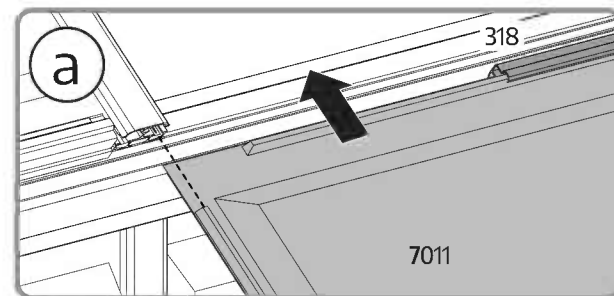
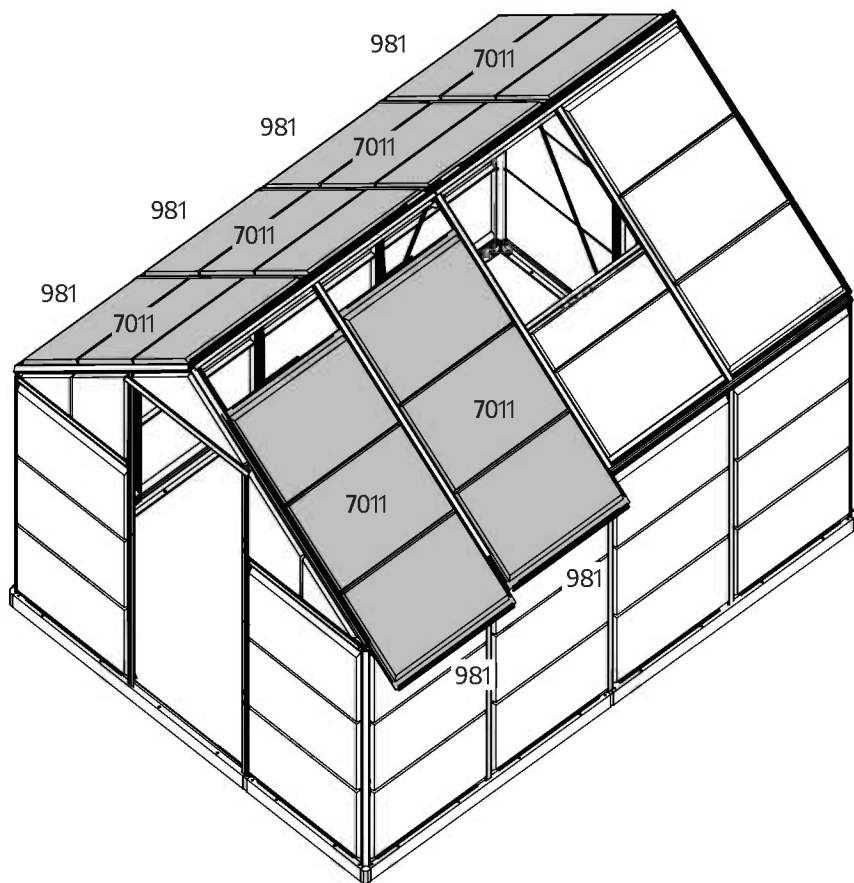

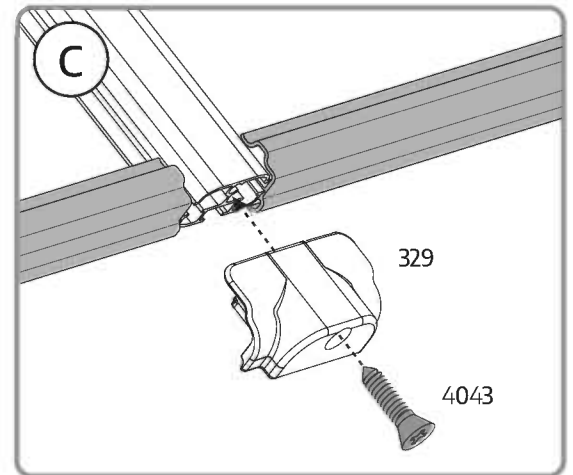
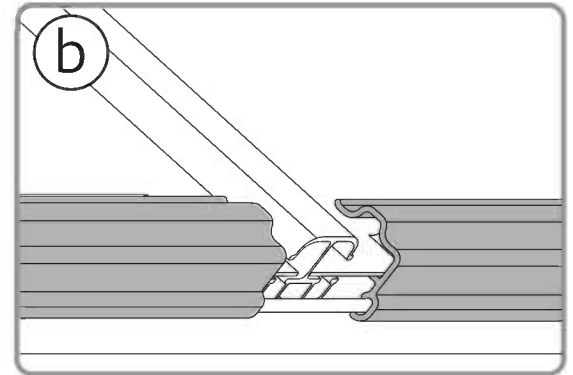
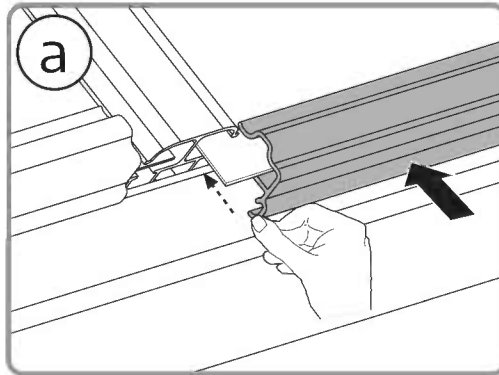
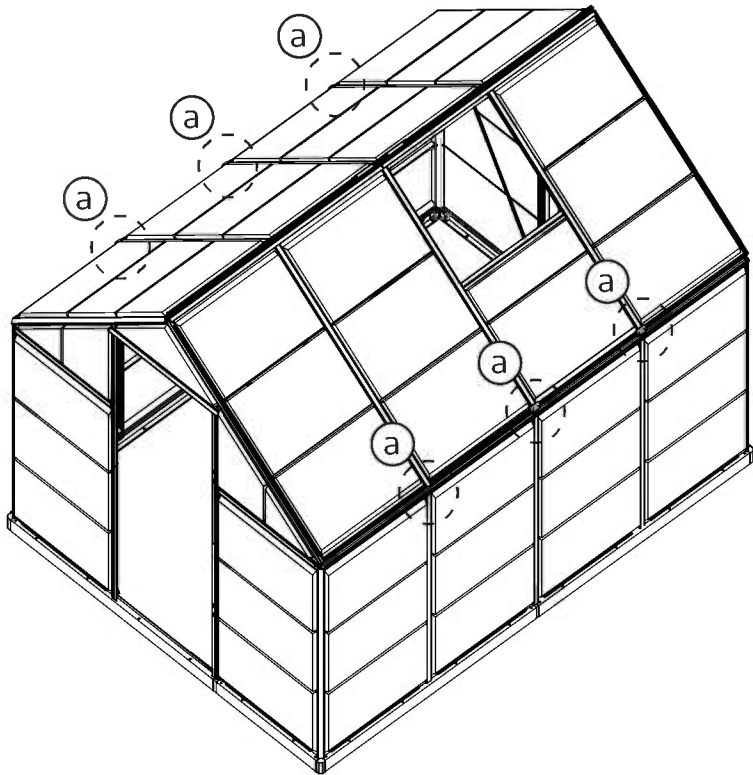
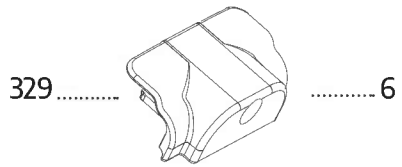
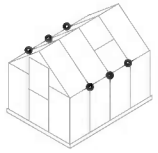

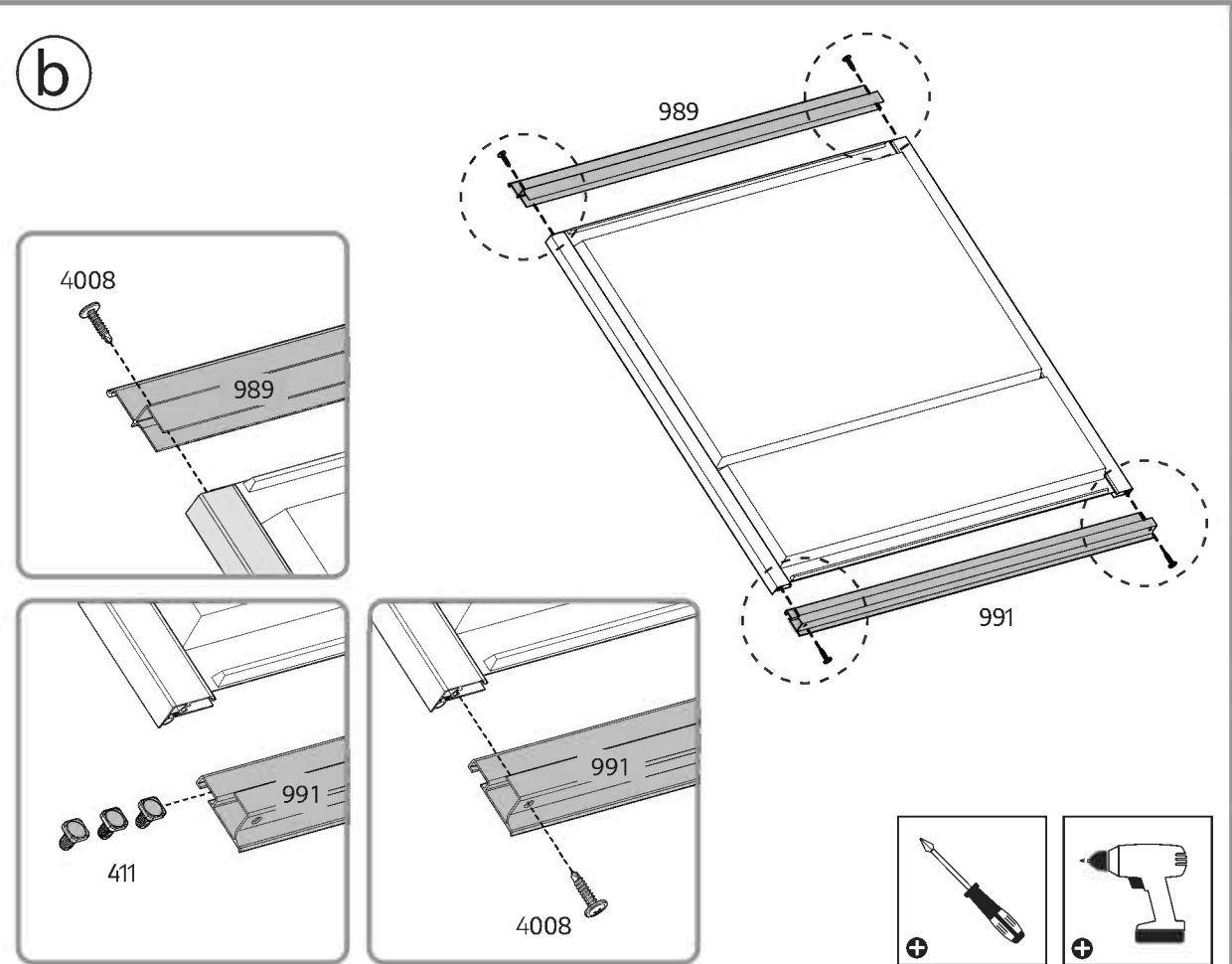
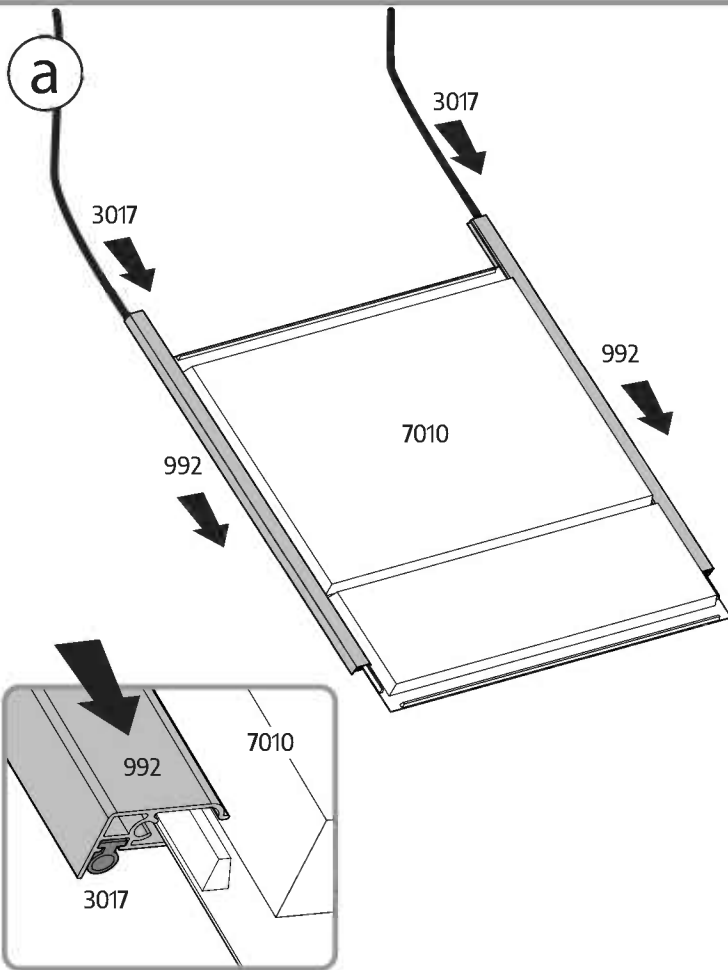
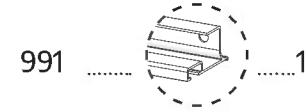
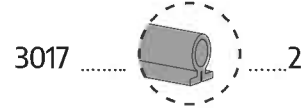
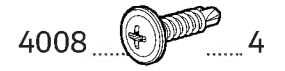
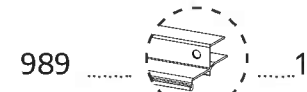
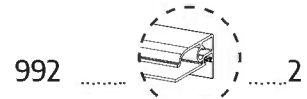
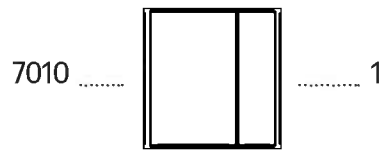
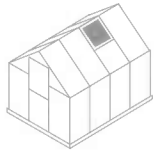

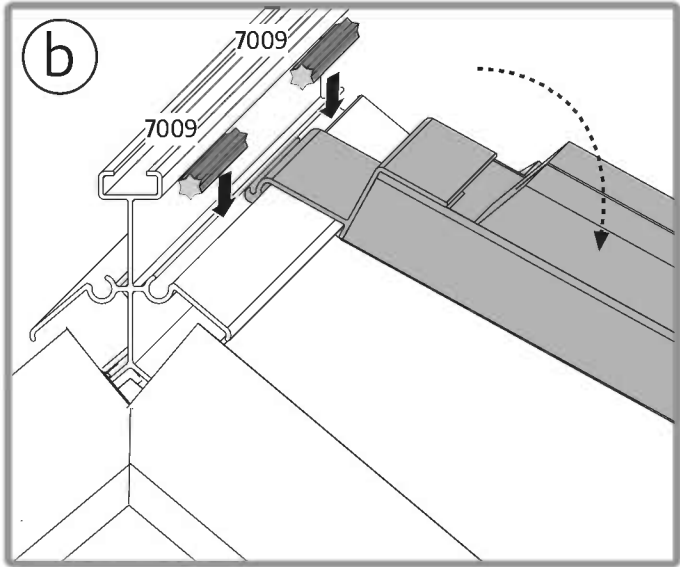
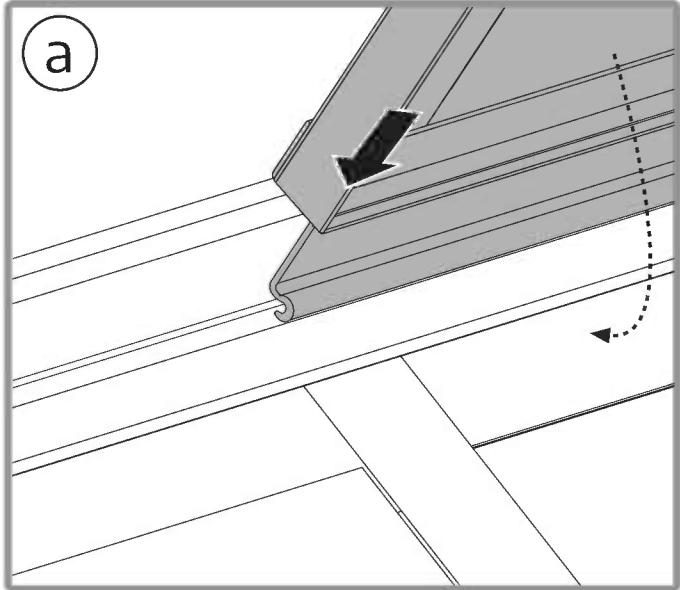
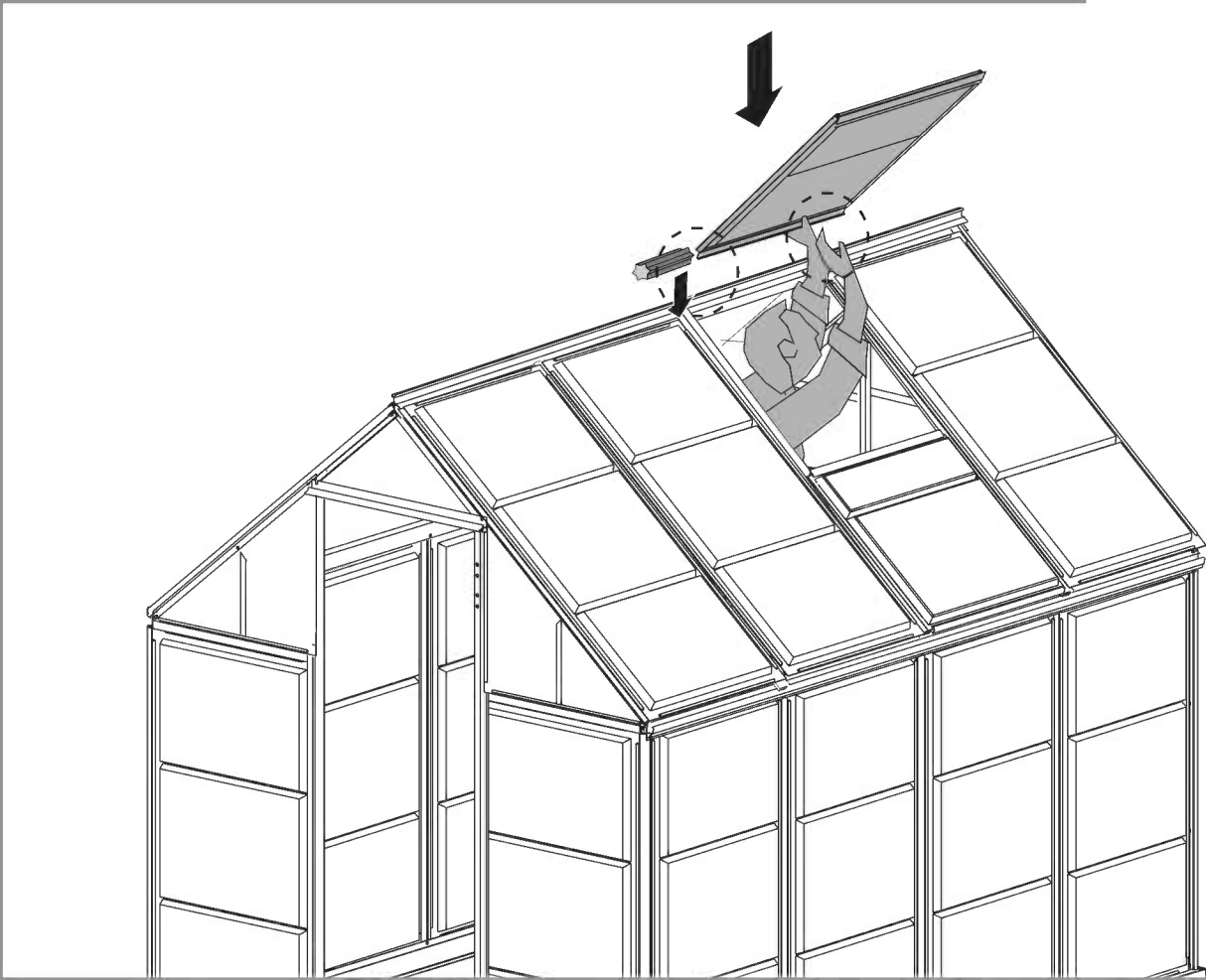

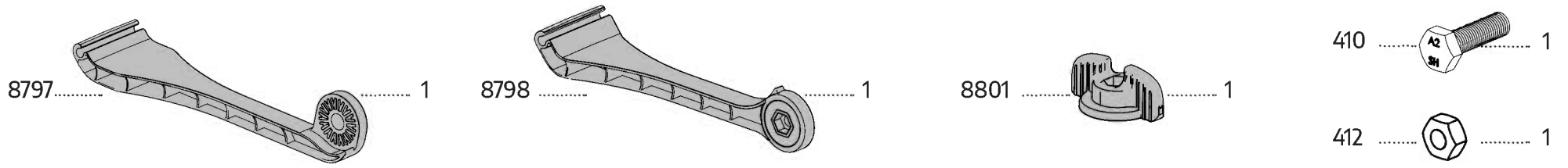
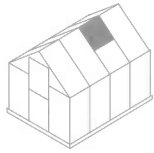

a

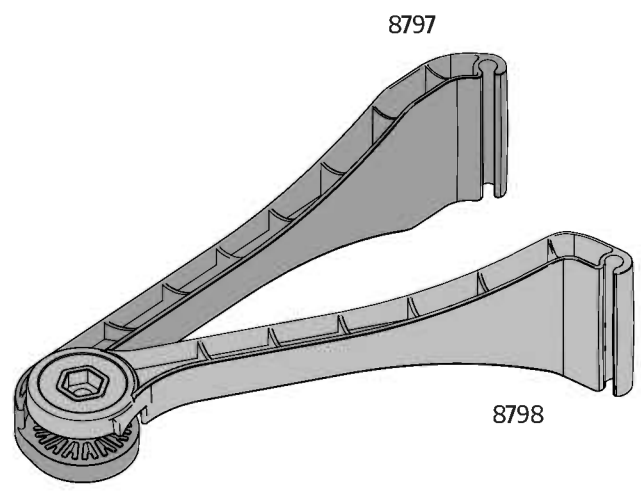

b

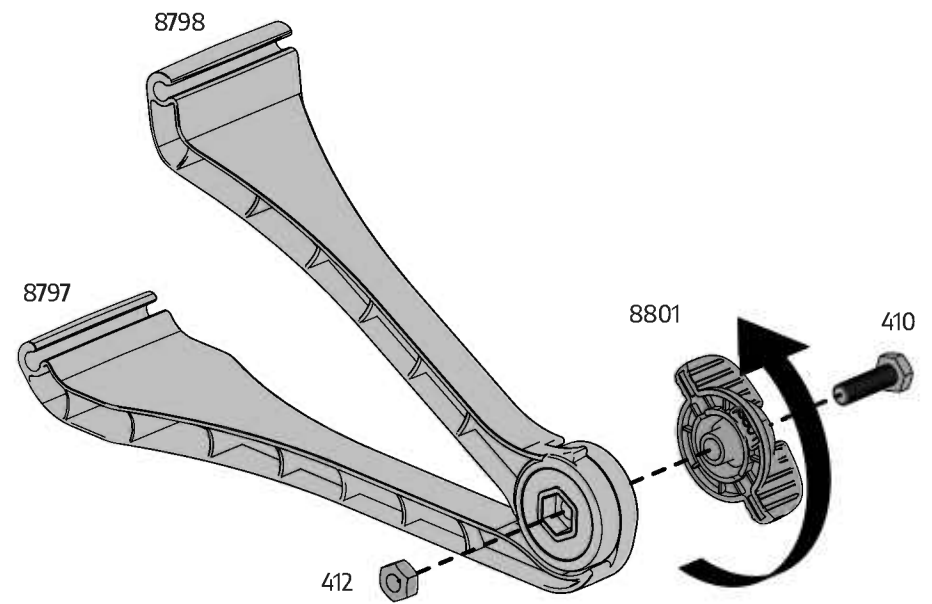

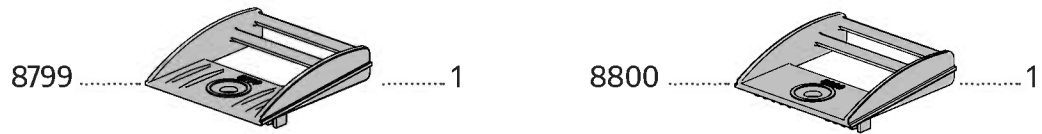
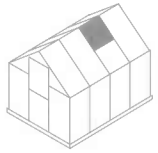

a

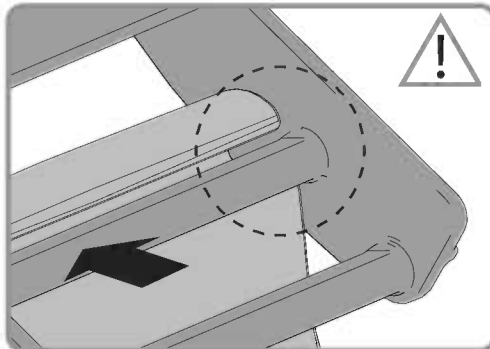
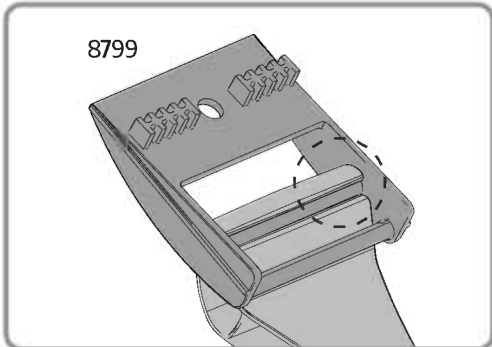
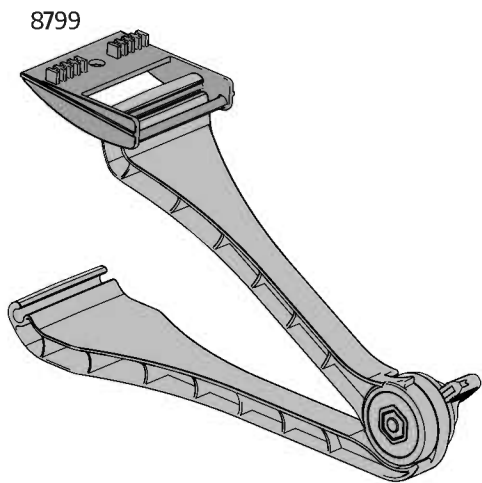

b

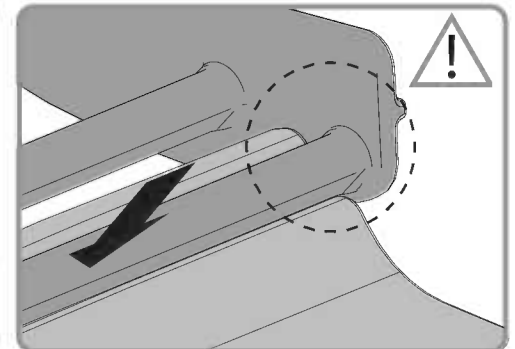
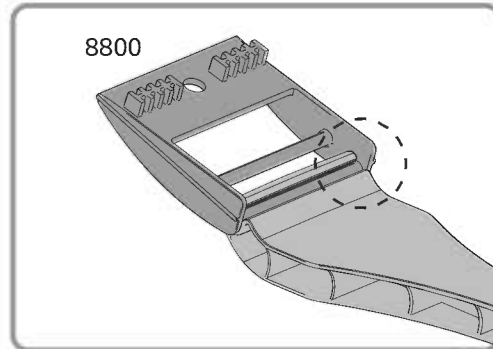
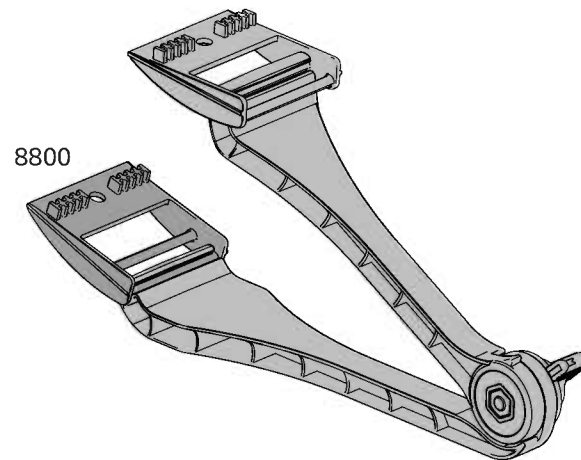



In case the window is not closed properly, please go to **Step 42**, release the screws, adjust the profile and tighten the screws.

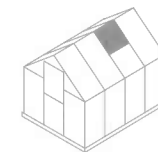

466.....2

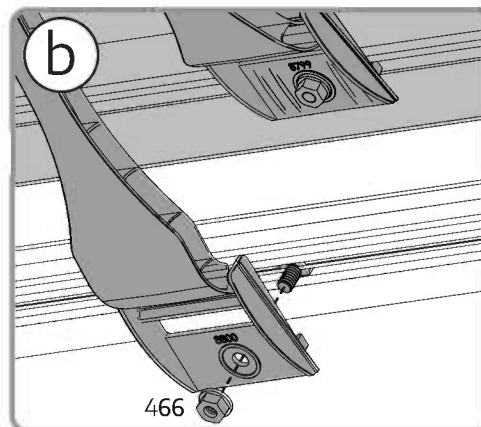
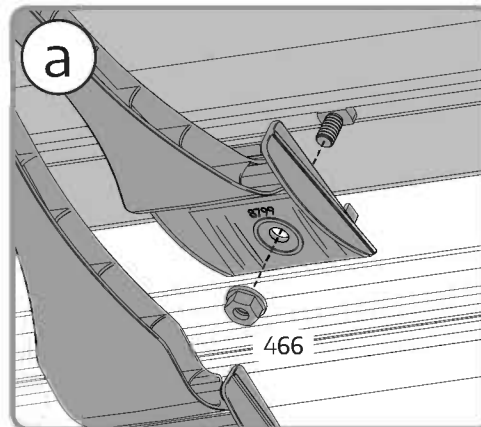
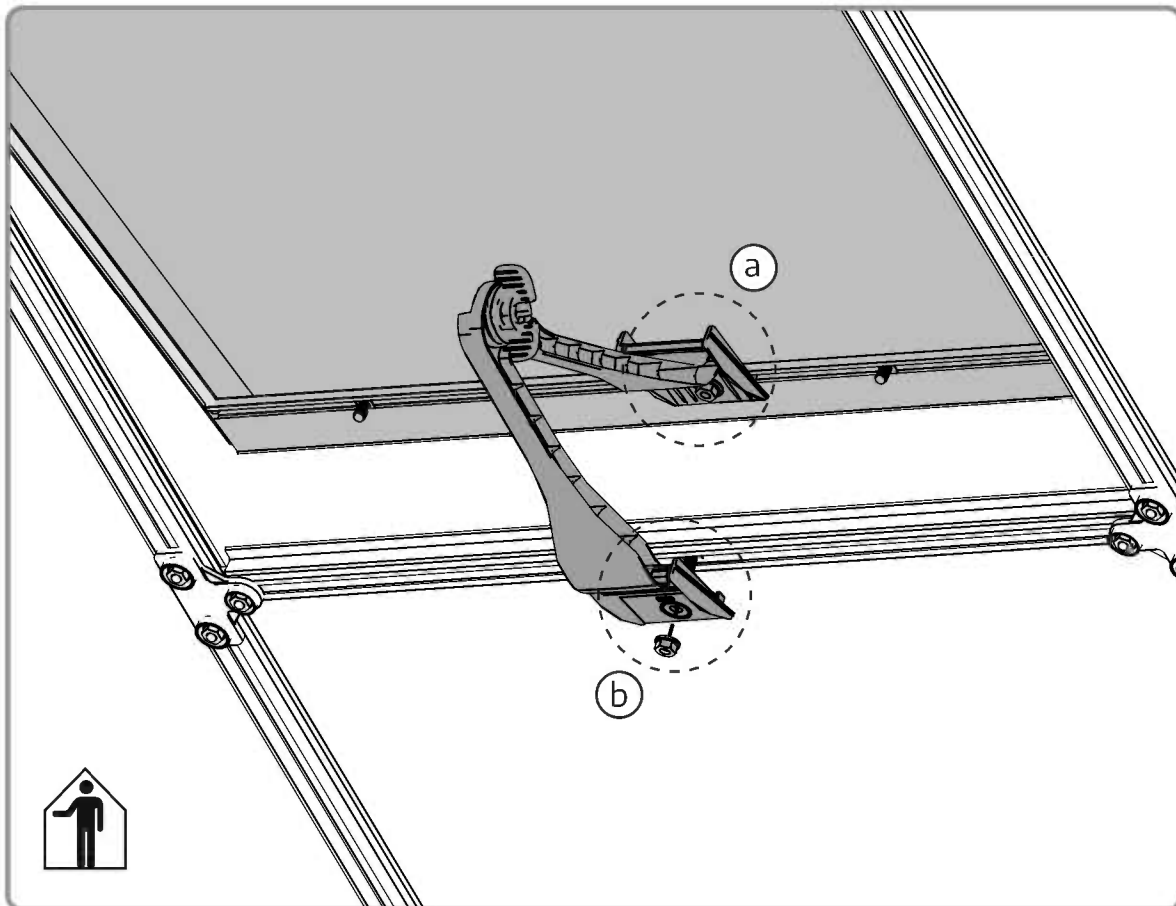

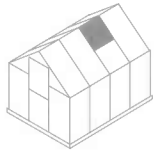

9953 2

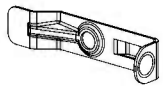

4044 2

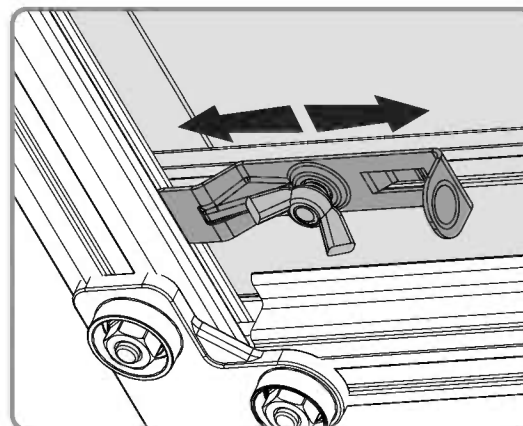
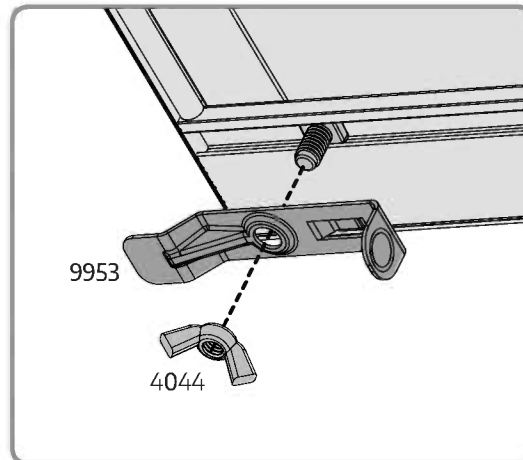
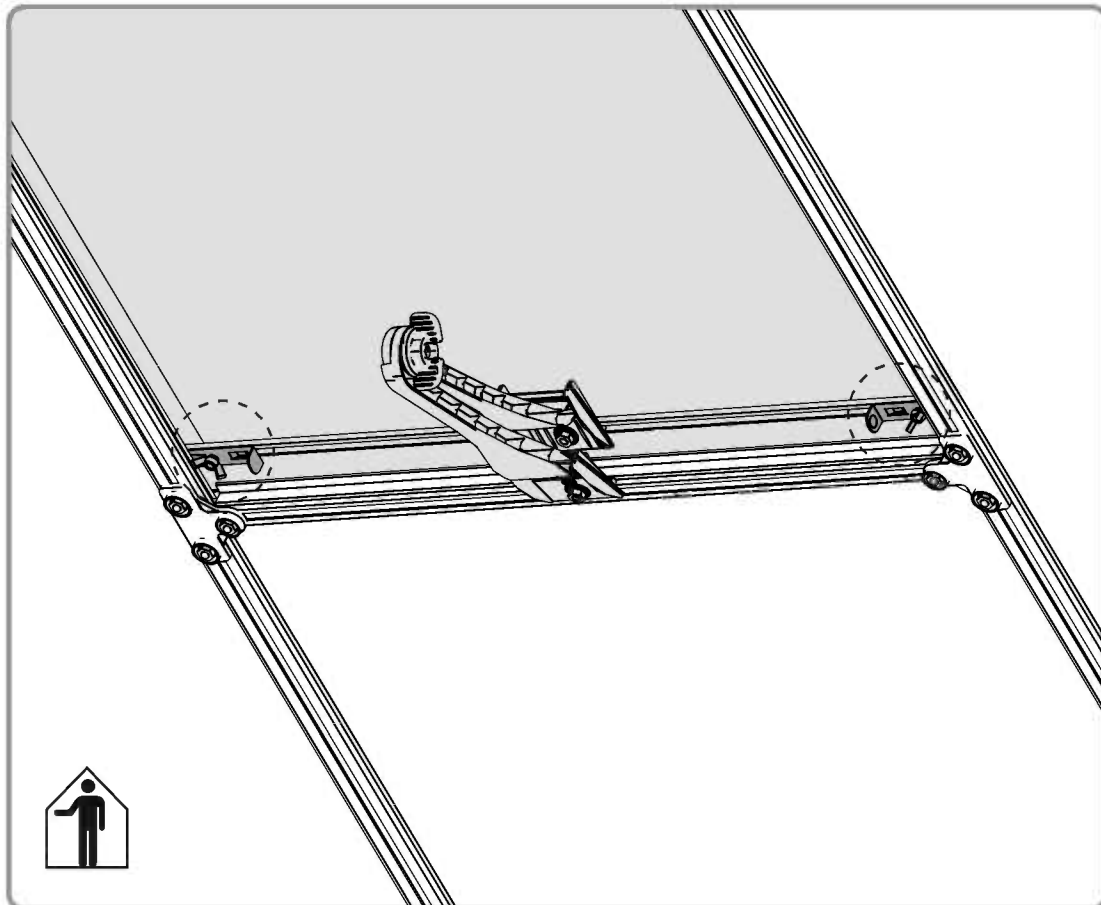



Determines door direction door post #7311 is where door hinges will be located **(Step 14)**.

Door assembly should be done according to this decision.

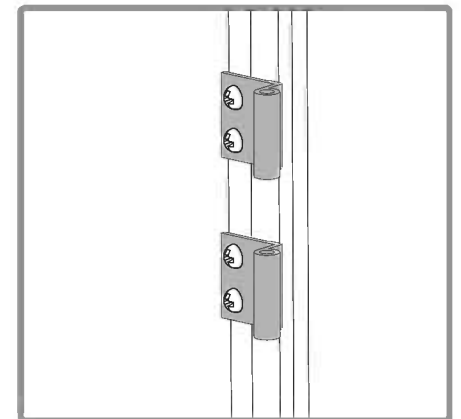
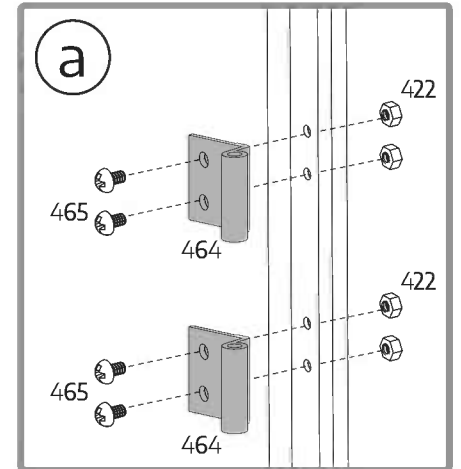
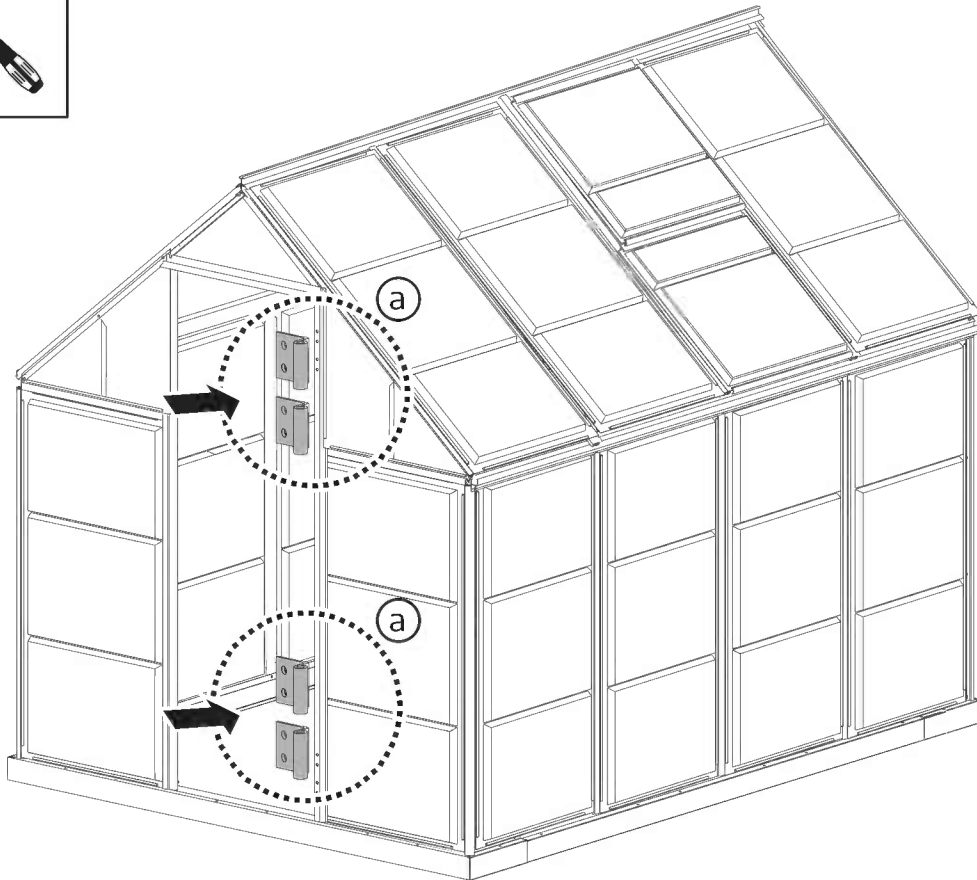
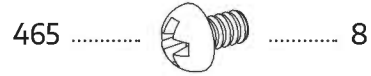
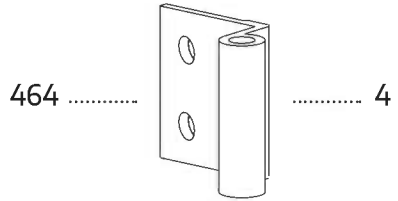
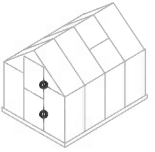

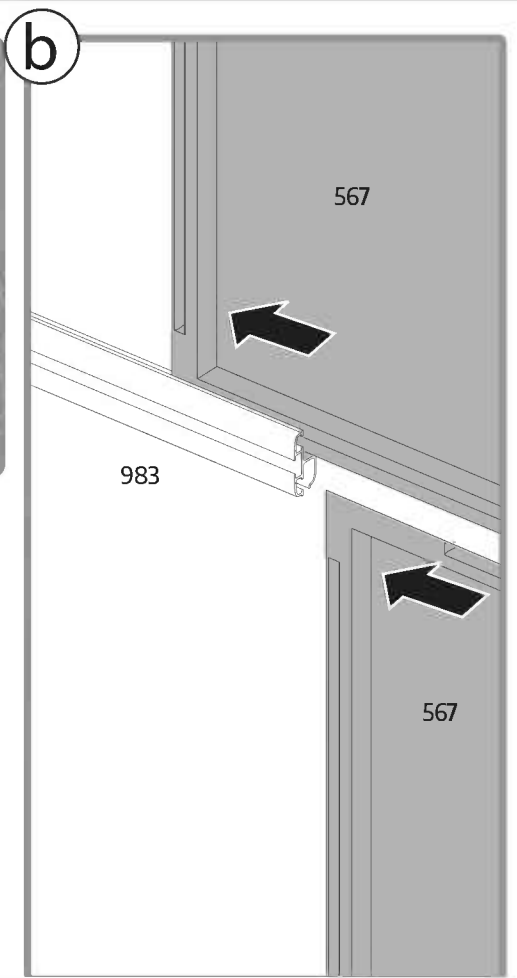
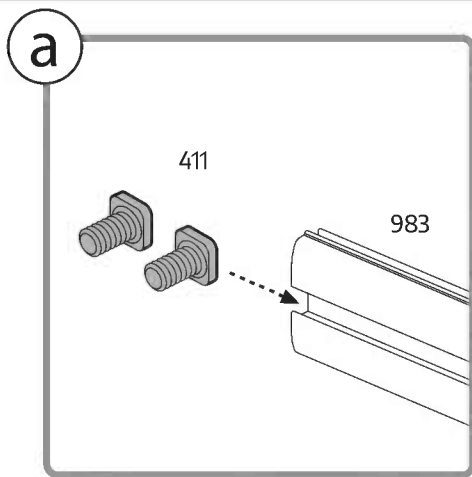
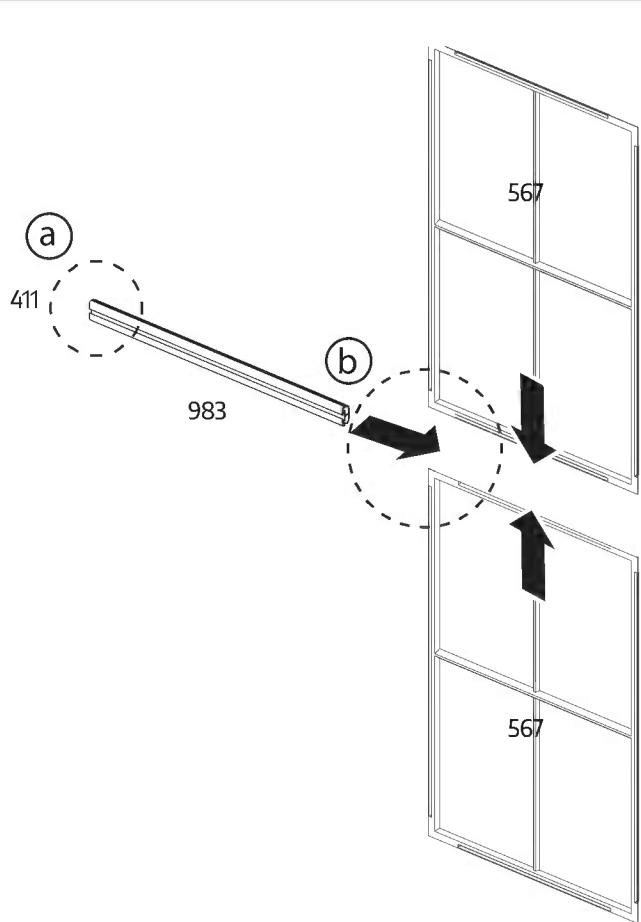
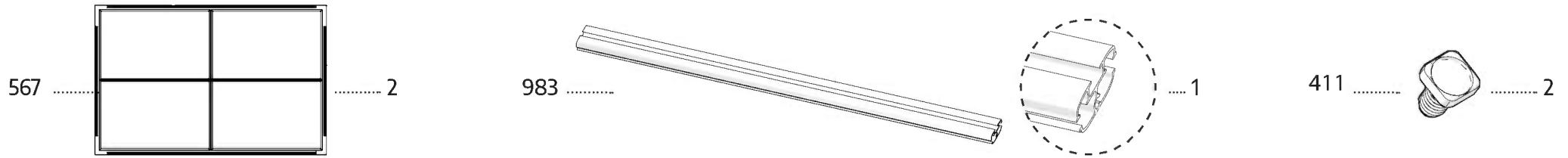
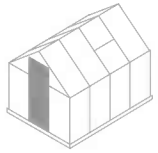

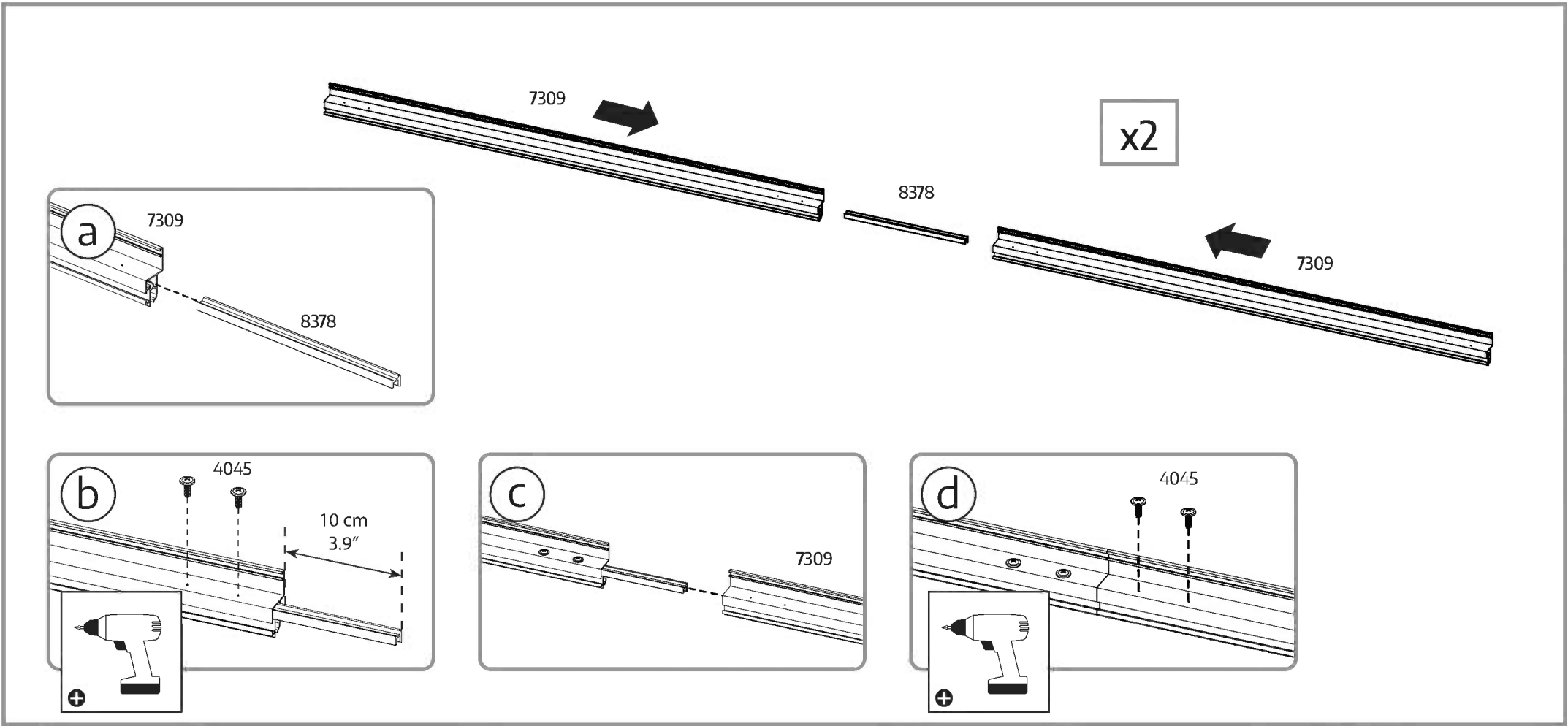
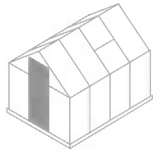

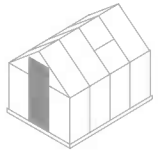

984



4008

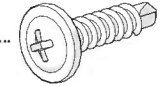

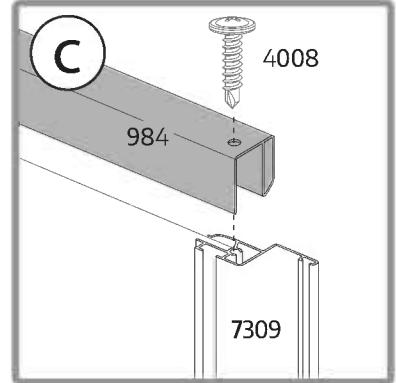
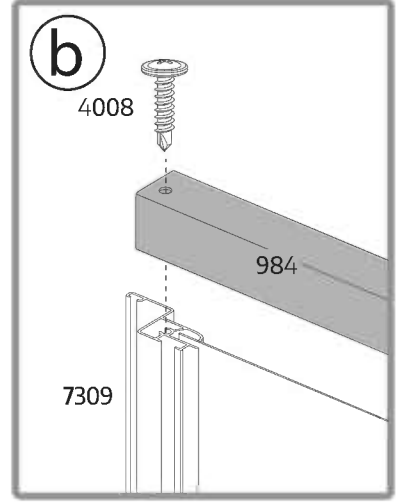
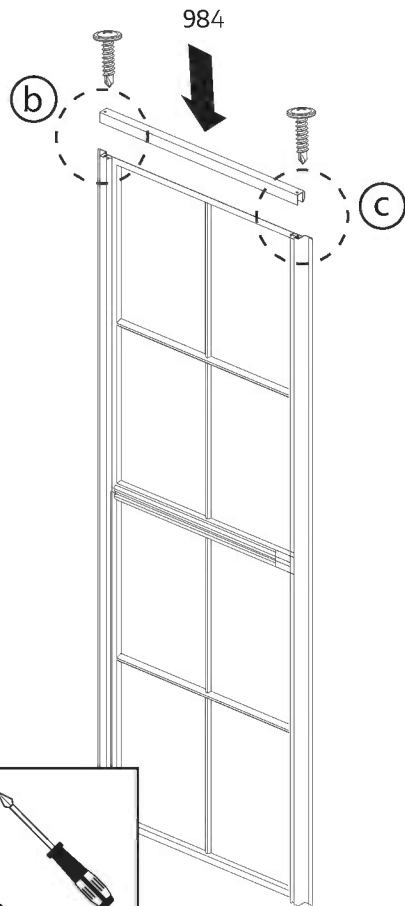
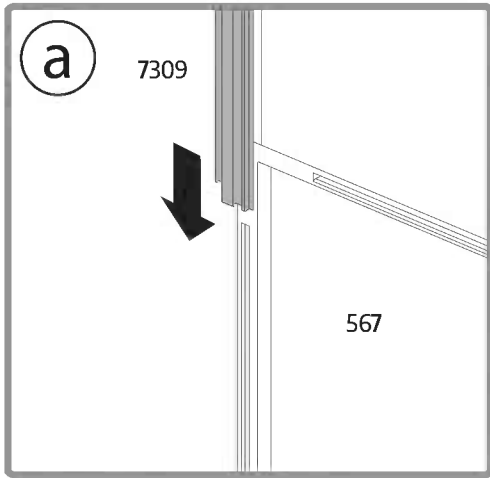
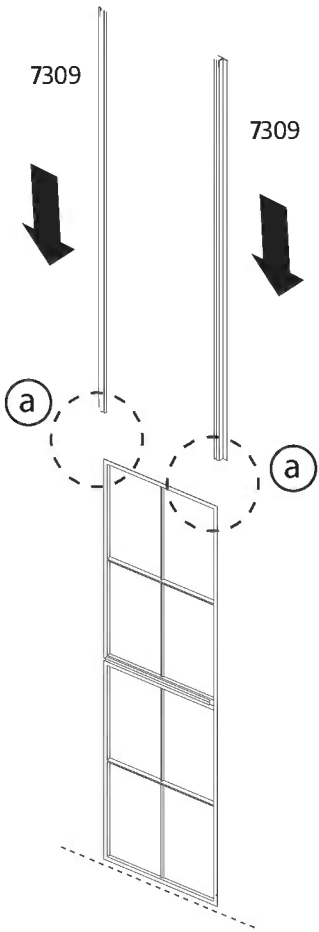

..... 2



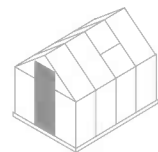

Determines door direction door post #7311 is where door hinges will be located **(Step 14)**.
Door assembly should be done according to this decision.



- 411  7
- 3016  1

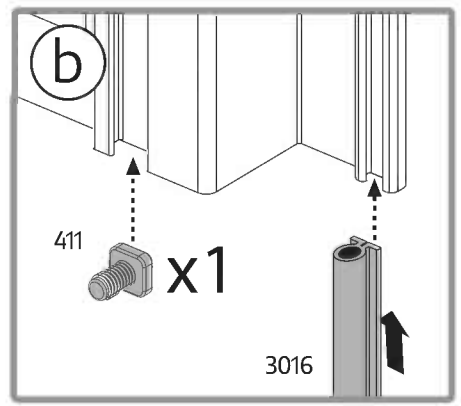
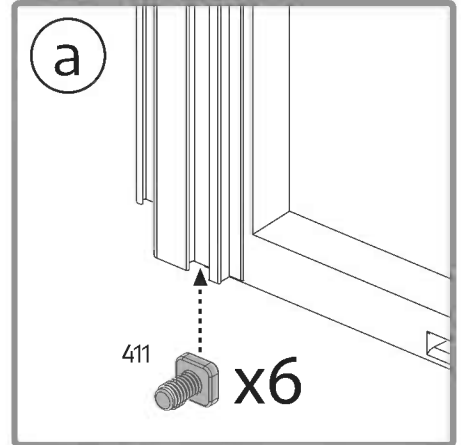
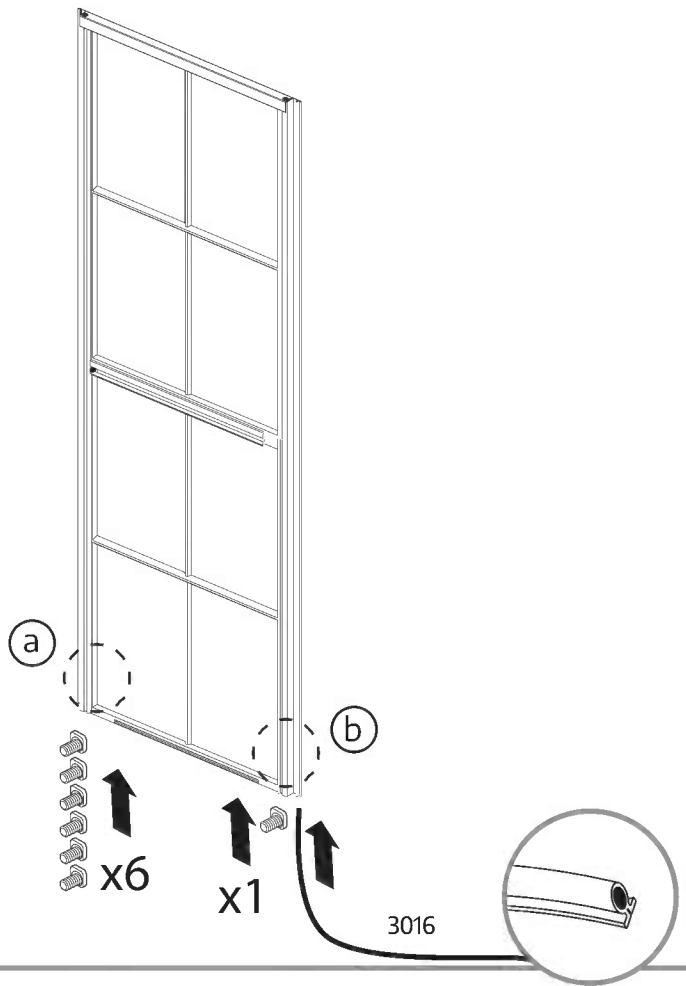



Determines door direction door post #7311 is where door hinges will be located **(Step 14)**.

Door assembly should be done according to this decision.

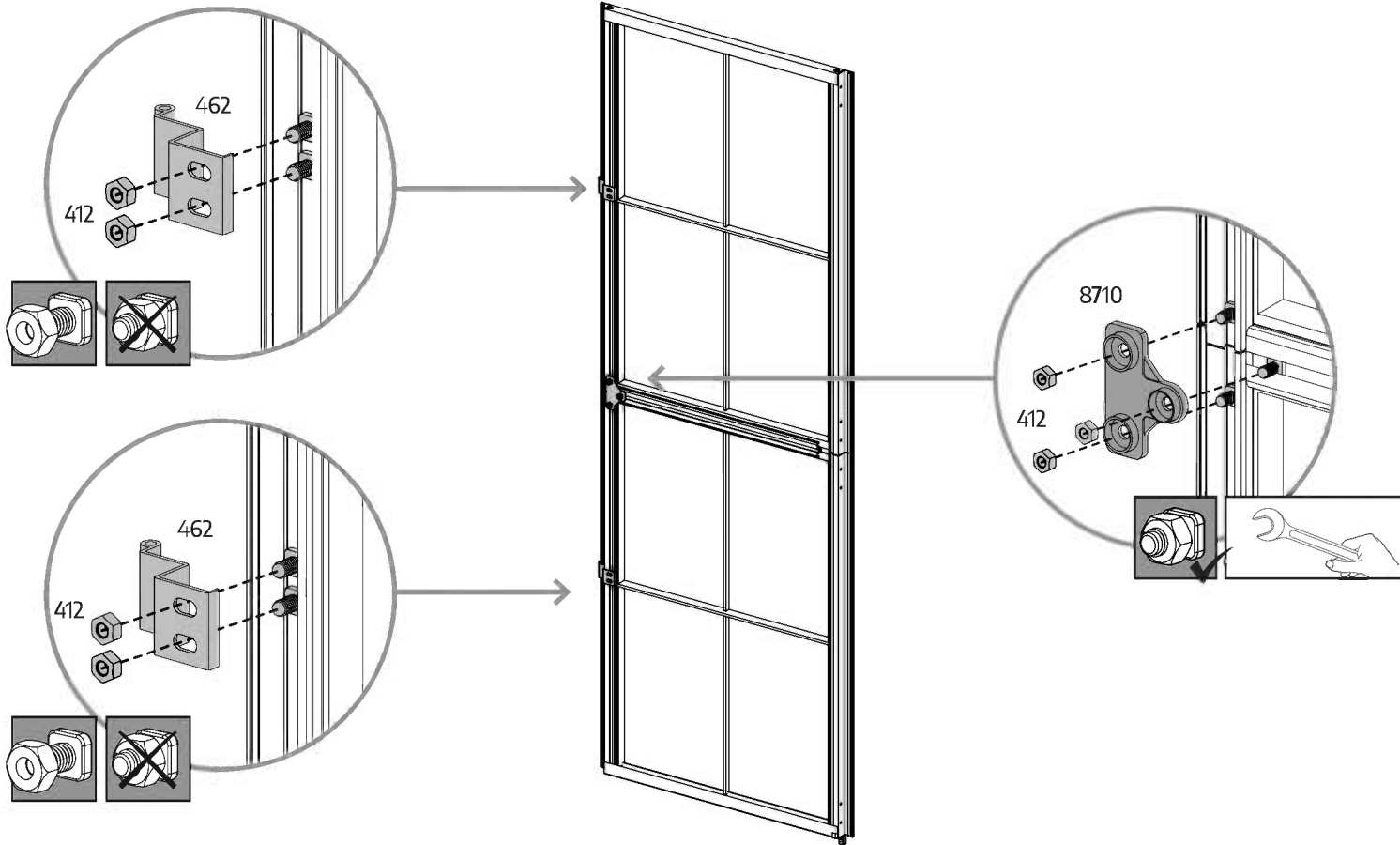
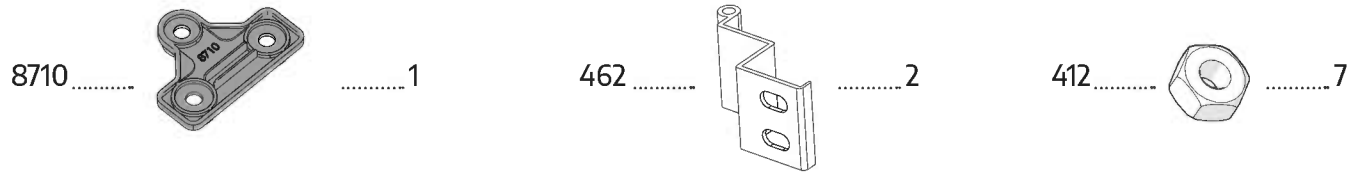
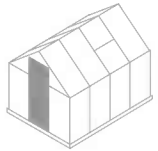



Determines door direction door post #7311 is where door hinges will be located **(Step 14)**.

Door assembly should be done according to this decision.

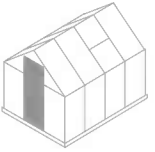

984 1

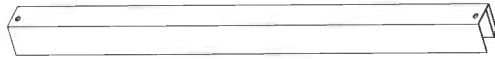

4037 1

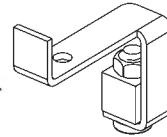

4008 2

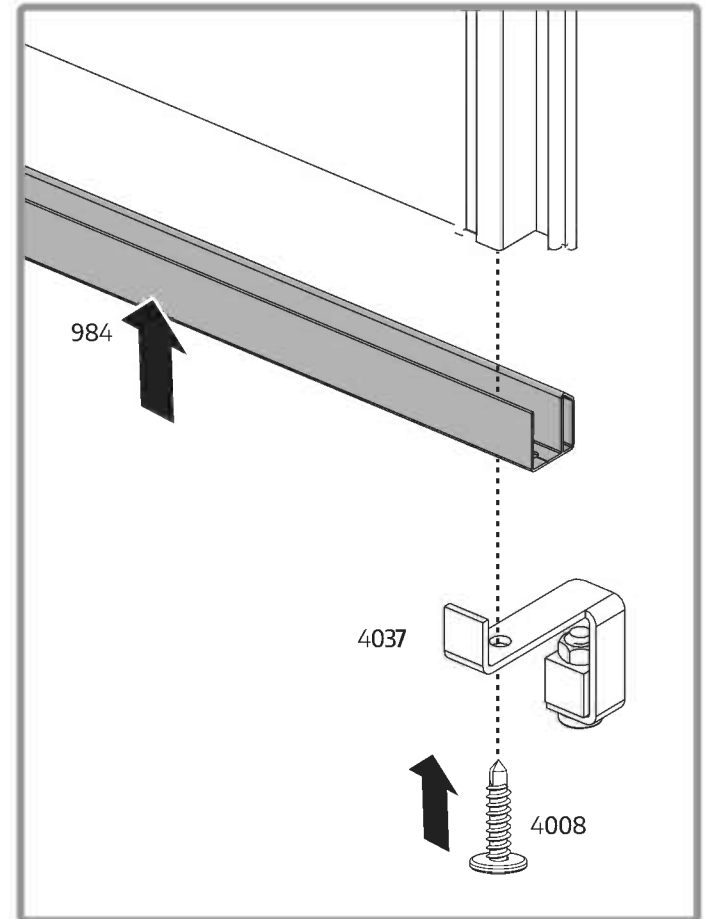
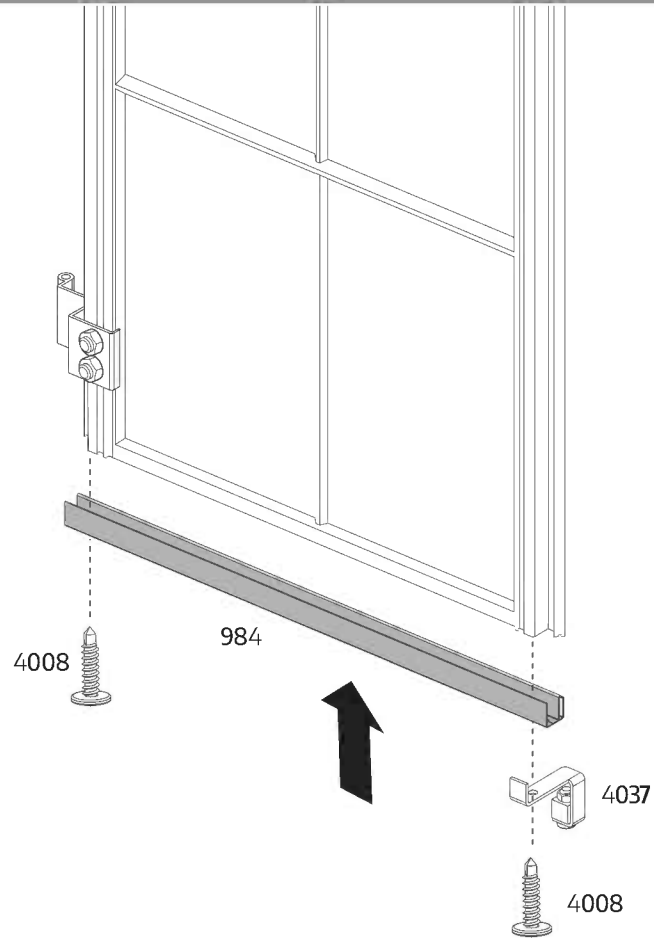
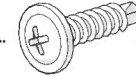



Determines door direction door post #7311 is where door hinges will be located **(Step 14)**.

Door assembly should be done according to this decision.

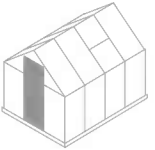

7086 1

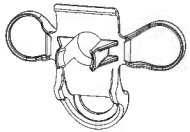

7085 1

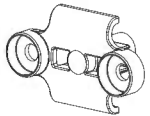

7084 1

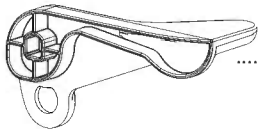

7083 1

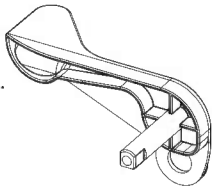

7088 1



M4 x 50 mm

423 1



412 2

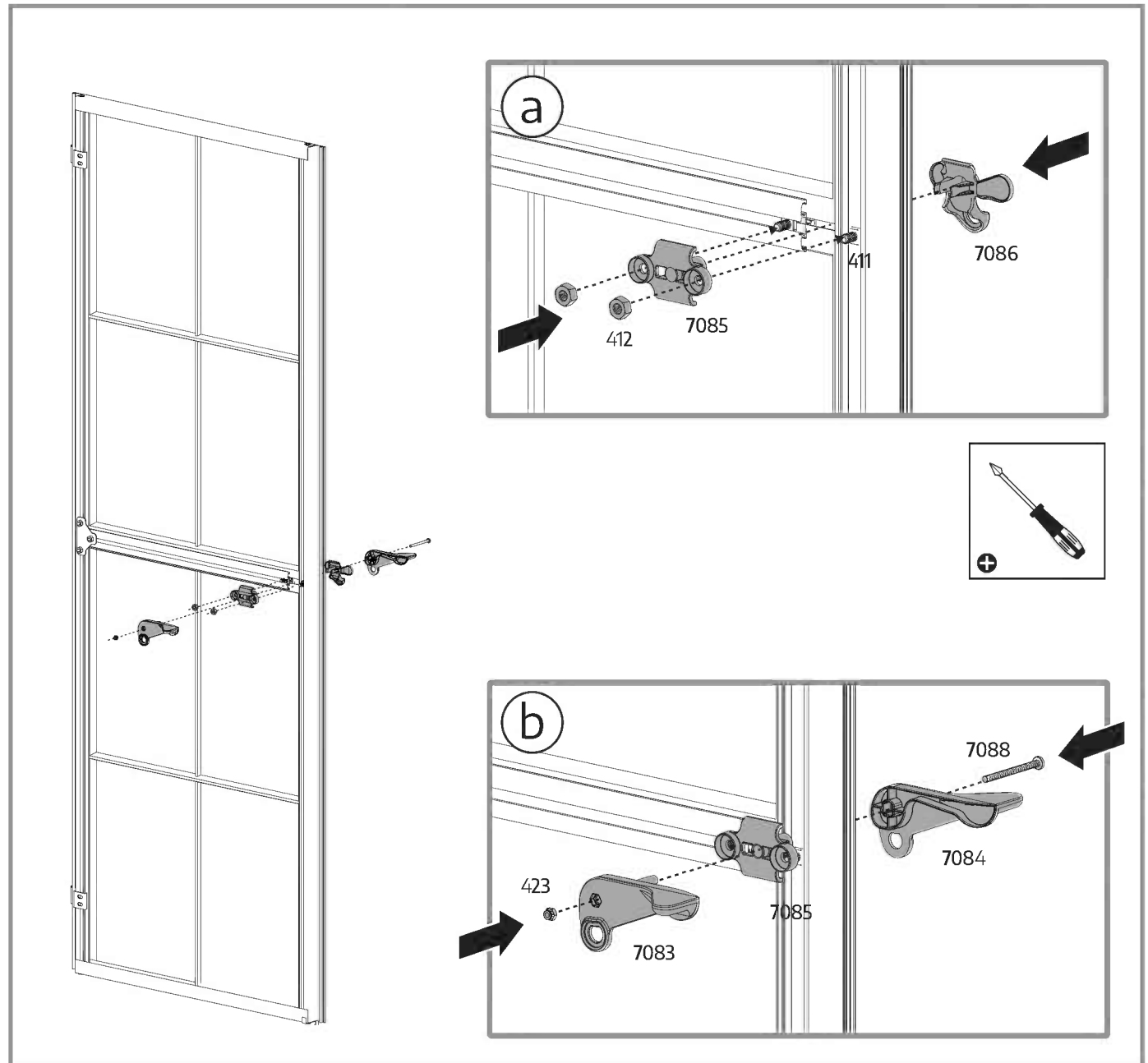



Determines door direction door post #7311 is where door hinges will be located **(Step 14)**.

Door assembly should be done according to this decision.

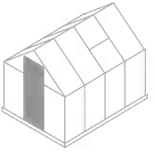

463  2

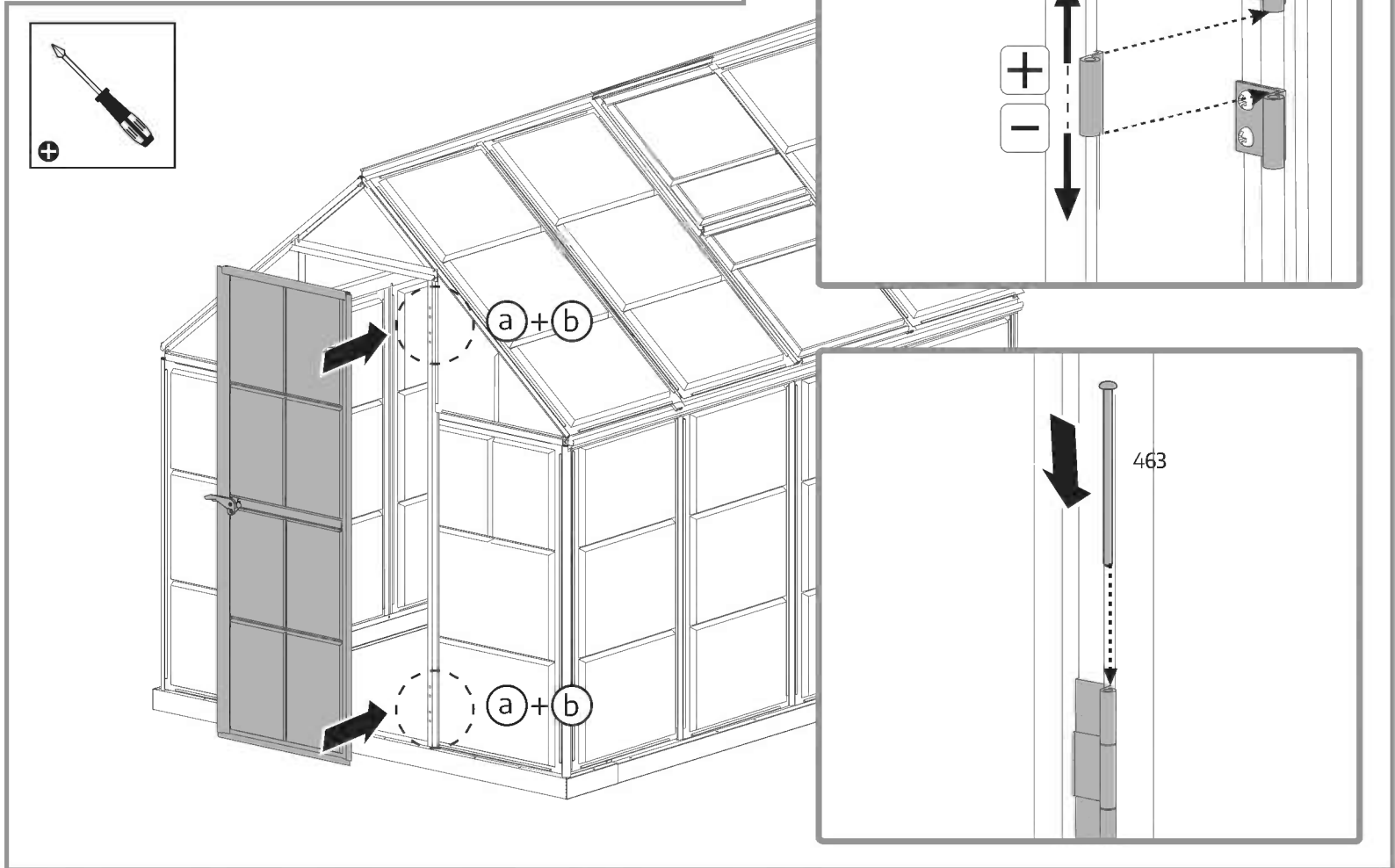
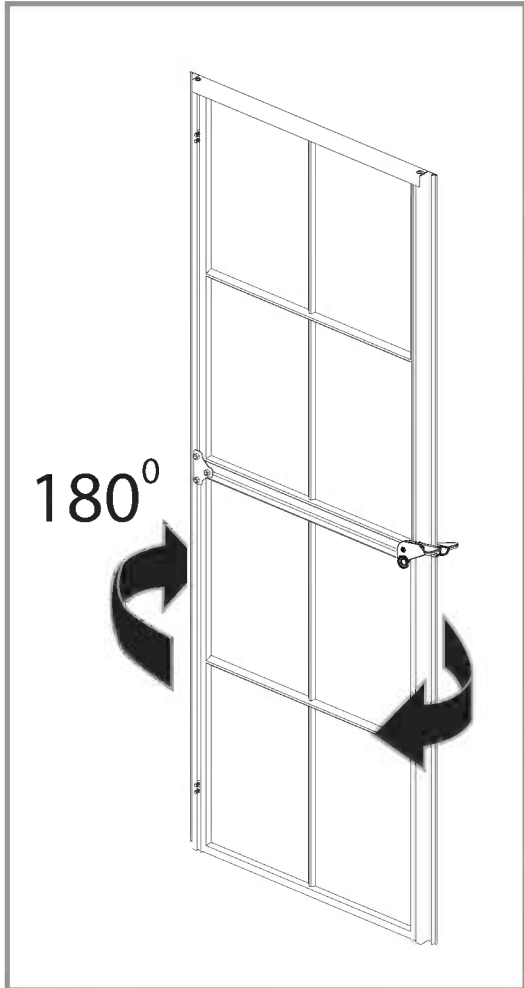

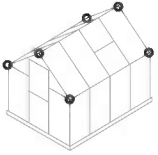

344 L 2 344 R 2 343 2 7442 4

a

b

343

344 L

344 R

7442

a

b

343

EN

PALRAM - CANOPIA | 5 YEAR LIMITED WARRANTY

Palram Canopia Ltd. (Company number: 512106824) whose registered office is at Teradion Industrial Park, M.P. Misgav 2017400, Israel ("Canopia") warrants that the product will be free from defects in material or workmanship for a period of 5 years from the original date of purchase. • This warranty is valid only if the product is installed, handled, cleaned, and maintained in accordance with Canopia's written specifications. • This warranty does not cover defects resulting from normal wear and tear including, but not limited to: damage caused by use of force, incorrect handling, inappropriate use, negligence, accidents, impact from foreign objects, vandalism, pollutants, alteration, painting, damage resulting from cleaning with incompatible detergents or minor deviations of the product. • This warranty does not apply to damage resulting from "acts of Nature", which includes but is not limited to hail, storm, tornado, hurricane, blizzard, flood, or fire. • Upon submitting proof of purchase and evidence of the claimed product failure, and subject to reporting the failure in writing within 30 days after discovery of the defect, Canopia, at its sole discretion, will replace defective parts of the Product, or refund you a prorated portion of the purchase price on a straight-line depreciated basis for the length of the warranty.

FR

GARANTIE LIMITÉE À 5 ANS DE PALRAM - CANOPIA

Palram Canopia Ltd. (Compagnie n° 512106824) dont le siège social est adressé au Parc Industriel Teradion, M.P. Misgav 2017400, Israël ("Canopia") garantit que le produit est exempt de tout défaut de matériau ou de fabrication pendant une période de 5 ans à compter de la date d'achat initiale. • Cette garantie n'est valable que si le produit est installé, manipulé, nettoyé et entretenu conformément aux spécifications établies par écrit de Canopia. • Cette garantie ne couvre pas les défauts résultant de l'usure normale, y compris, mais sans s'y limiter, les suivants : dommages causés par le forçage du produit, une mauvaise manipulation, une utilisation incorrecte, la négligence, les accidents, l'impact de corps étrangers, le vandalisme, les contaminants, les modifications, l'application de peinture, le nettoyage avec des détergents incompatibles ou les modifications mineures du produit. • Cette garantie ne s'applique pas aux dommages résultant de "catastrophes naturelles", y compris, mais sans s'y limiter, la grêle, les tempêtes, les tornades, les ouragans, les blizzards, les inondations ou les incendies. • Sur présentation de la preuve d'achat du Produit ainsi que de la preuve de la défaillance alléguée, et à condition que vous signaliez la défaillance par écrit dans les 30 jours suivant la découverte du défaut, Canopia remplacera, à sa seule discrétion, les pièces défectueuses du produit ou vous remboursera une partie proportionnelle du prix d'achat sur une base d'amortissement linéaire pour la durée de la garantie.

DE

5 JAHRE BESCHRÄNKTE GARANTIE VON PALRAM - CANOPIA

Palram Canopia Ltd. (Firmennummer: 512106824) mit Sitz in Teradion Industrial Park, M.P. Misgav 2017400, Israel („Canopia“) garantiert, dass das Produkt für einen Zeitraum von 5 Jahren ab dem ursprünglichen Kaufdatum frei von Material- und Verarbeitungsfehlern ist. • Diese Garantie ist nur gültig, wenn das Produkt gemäß den schriftlichen Spezifikationen von Canopia installiert, behandelt, gereinigt und gewartet wird. • Diese Garantie deckt keine Defekte ab, die auf normalen Verschleiß zurückzuführen sind, einschließlich, aber nicht beschränkt auf: Schäden, die durch Gewaltanwendung, falsche Handhabung, unsachgemäßen Gebrauch, Fahrlässigkeit, Unfälle, Einwirkungen von Fremdkörpern, Vandalismus, Schadstoffe, Veränderungen, Anstriche, Schäden, die durch Reinigung mit unverträglichen Reinigungsmitteln entstanden sind, oder geringfügige Abweichungen des Produkts. • Diese Garantie gilt nicht für Schäden, die durch „höhere Gewalt“ entstanden sind, wie z. B. Hagel, Sturm, Tornado, Orkan, Schneesturm, Überschwemmung oder Feuer. • Bei Einreichung des Kaufbelegs und des Nachweises des beanstandeten Produktfehlers und vorbehaltlich der schriftlichen Meldung des Fehlers innerhalb von 30 Tagen nach Entdeckung des Fehlers ersetzt Canopia nach eigenem Ermessen die fehlerhaften Teile des Produkts oder erstattet Ihnen einen anteiligen Teil des Kaufpreises auf linearer Abschreibungsbasis für die Dauer der Garantie.

ES

GARANTÍA LIMITADA DE 5 AÑOS DE PALRAM - CANOPIA

Palram Canopia Ltd. (Número de la compañía: 512106824) cuya oficina registrada se encuentra en Teradion Industrial Park, M.P. Misgav 2017400, Israel ("Canopia") garantiza que el producto estará libre de defectos de material o de fabricación durante un periodo de 5 años a partir de la fecha inicial de compra. • Esta garantía solo es válida si el producto se instala, manipula, limpia y mantiene de acuerdo con las especificaciones por escrito de Canopia. • Esta garantía no cubre los defectos resultantes del desgaste normal, entre lo que se incluye, entre otras cosas, lo siguiente: daños causados al forzar el producto, al manipularlo de forma incorrecta, al emplearlo de forma inapropiada, por negligencia, por accidentes, por impactos de objetos extraños, por vandalismo, por contaminantes, por modificaciones, por haber sido pintado, por la limpieza con detergentes incompatibles o por pequeñas modificaciones del producto. • Esta garantía no se aplica a los daños que resulten de "fenómenos naturales", lo que incluye, pero no se limita, al granizo, las tormentas, los tornados, los huracanes, las ventiscas, las inundaciones o los incendios. • Al presentar el comprobante de compra del producto así como una prueba de la falla que se reclama, y a condición de reportar la falla por escrito dentro de los 30 días siguientes al descubrimiento del defecto, Canopia, a su sola discreción, sustituirá las partes defectuosas del Producto, o le reembolsará una porción prorrateada del precio de compra de acuerdo a una base de depreciación lineal según la duración de la garantía.

SV

BEGRÄNSNINGAR I PALRAM - CANOPIA 5-ÅRS GARANTI

Palram Canopia Ltd. (Bolagsnummer: 512106824) vars registrerade huvudkontor har adressen: Teradion Industrial Park, M.P. Misgav 2017400, Israel ("Canopia") garanterar att produkten är fri från material- och tillverkningsfel under en period av 5 år från det ursprungliga inköpsdatumet. • Garantin gäller endast om produkten installeras, hanteras, rengörs och underhålls i enlighet med Canopias skriftliga specifikationer. • Garantin täcker inte defekter som beror på normalt slitage, inklusive, men inte begränsat till: skador som orsakats av våld, felaktig hantering, olämplig användning, vårdslöshet, olyckor, påverkan från främmande föremål, vandalism, föroreningar, ändring, målning, skador som orsakats av rengöring med inkompatibla rengöringsmedel eller smärre avvikelser av produkten. • Denna garanti gäller inte för skador till följd av "naturkatastrofer", vilket inkluderar men inte är begränsat till hagel, storm, tornado, orkan, snöstorm, översvämning eller brand. • Mot uppvisande av inköpsbevis och bevis för det påstådda produktfelet, och under förutsättning att felet rapporteras skriftligen inom 30 dagar efter upptäckten av felet, kommer Canopia, efter eget gottfinnande, att byta ut defekta delar av produkten eller återbetala dig en proportionell del av inköpspriset på linjär avskrivningsbasis under garantins längd.

NN

PALRAM - CANOPIAS 5 ÅRS BEGRENSEDE GARANTI

Palram Canopia Ltd. (Selskapsnummer: 512106824) med hovedkontor i Teradion Industrial Park, M.P. Misgav 2017400, Israel ("Canopia") garanterer at produktet vil være uten defekter i materiale eller utførelse i en periode på 5 år fra den opprinnelige kjøpsdatoen. • Denne garantien gjelder bare hvis produktet er installert, håndtert, rengjort og vedlikeholdt i henhold til Canopias skriftlige spesifikasjoner. • Denne garantien dekker ikke feil som skyldes normal slitasje, inkludert, men ikke begrenset til: skade forårsaket av bruk av makt, feil håndtering, upassende bruk, uaktsomhet, ulykker, påvirkning fra fremmedlegemer, hærverk, miljøgifter, endring, maling, skade som følge av rengjøring med inkompatible vaskemidler eller mindre avvik i produktet. • Denne garantien gjelder ikke for skader som følge av naturfenomener, inkludert, men ikke begrenset til, hagl, storm, tornado, orkan, snøstorm, flom eller brann. • Ved innlevering av kvittering på kjøp og bevis på den påståtte produktfeilen, og med forbehold om skriftlig rapportering av feilen innen 30 dager etter oppdagelsen av feilen, vil Canopia, etter eget skjønn, erstatte defekte deler av produktet, eller refundere deg en del av kjøpesummen beregnet ved bruk av lineær metode på grunnlag av garantiens varighet.

Declaration of Performance

No 0202
Year of Affix :23

Palram-Canopia Greenhouse - Hybrid™ / Harmony™ / Mythos™

1. The reference of the product-type for which the declaration of performance has been drawn up.
Palram-Canopia Greenhouse - Hybrid / Harmony / Mythos.

2. The system or systems of assessment and verification of constancy of performance of the construction product, as set out in Annex V. System 2+

3. The reference number and date of issue of the harmonised standard or the European Technical Assessment which has been used for the assessment of each essential characteristic: EN 1090-1:2009+A1:2011

4. Where applicable, the reference number of the Specific Technical Documentation used and the requirements with which the manufacturer claims the product complies.

- EN1090-1 Execution of steel structures and aluminium structures
Part 1: Requirements for conformity assessment of structural components
- EN1090-3 Execution of steel structures and aluminium structures
Part 3: Technical requirements for aluminium structures
- EN 1990 Basis for structural design
- EN 1991 Actions on Structures
- EN 1999 Design of aluminium structures

5. The intended use or uses for the construction product, in accordance with the applicable harmonised technical specification: Greenhouse for domestic customers.

6. The performance of the essential characteristics of the construction product.

- Tolerances on dimensions and shape: EN1090-3 - Annex G
- Weldability: NPD
- Fracture toughness/impact resistance: NPD (aluminium structure)
- Load bearing capacity:
 - Maximum permitted Wind zone: 21 m/s defined as once in 50-year return probability interval, value at 10m from ground, averaged over 10min, terrain category II (open landscape)
 - Maximum permitted Snow zone: 0.50 kN/m² defined as once in 50-year return probability interval
- Resistance to fire: Class A
- Deformations and Deflections: NPD
- Release of cadmium and its compound: NPD
- Radioactivity: NPD
- Durability: NPD

7. EXC -1

8. Manufacturer: Palram Canopia Ltd. Teradion Industrial Park, M.P Misgav 2017400, P.O.B. 53, Israel

9. Importer and EU representative : Palram DE GmbH, Calbesche Str. 25, 39218 Schönebeck, Deutschland

10. Name and identification number of the notified body: 0906-CPR - 20000210005796

Signed for and behalf of Palram Canopia Ltd. by:
Teradion Industrial Park, M.P Misgav
2017400, P.O.B 53, Israel

12.01.2023

(Place & date of issue)

PALRAM CANOPIA

(Signature)

Déclaration de Performance

No 0202

Année d'affixe: 23

Serre de jardin Palram-Canopia - Hybrid™ / Harmony™ / Mythos™

1. La référence du type de produit pour lequel la déclaration de performance a été établie.

Serre de jardin Palram-Canopia - Hybrid / Harmony / Mythos.

2. Le ou les systèmes d'évaluation et de vérification de la constance des performances du produit de construction, tels que définis à l'annexe V. Système 2+

3. Le numéro de référence et la date de publication de la norme harmonisée ou de l'évaluation technique européenne qui a été utilisée pour l'évaluation de chaque caractéristique essentielle: EN 1090-1:2009+A1:2011

4. Le cas échéant, le numéro de référence de la documentation technique spécifique utilisée et les normes auxquelles le fabricant prétend que le produit est conforme.

- EN1090-1 Normes de structures en acier et structures en aluminium
Partie 1: Exigences pour l'évaluation de la conformité des composants structurels
- EN1090-3 Exécution de structures en acier et structures en aluminium
Partie 3: Normes techniques pour les structures en aluminium
- EN 1990 Base pour la conception structurelle
- EN 1991 Actions sur les structures
- EN 1999 Conception de structures en aluminium

5. L'utilisation ou les utilisations prévues pour le produit de construction, conformément à la spécification technique harmonisée applicable : Serre de jardin pour les particuliers.

6. La performance des caractéristiques essentielles du produit de construction.

- Tolérances sur dimensions et forme: EN1090-3 - Annexe G
- Soudabilité: NPD
- Résistance à la rupture / résistance aux chocs: NPD (structure en aluminium)
- Capacité de chargement:
 - Zone de vent maximale autorisée: 21 m / s définie comme une fois dans l'intervalle de probabilité de retour de 50 ans, valeur à 10 m du sol, moyenne sur 10 min, catégorie de terrain II (paysage ouvert)
 - Zone de neige maximale autorisée : 0,50 kN/m² définie comme un intervalle de probabilité de retour de 50 ans.
- Résistance au feu: Classe A
- Déformations et déflexions: NPD
- Libération de cadmium et de son composé: NPD
- Radioactivité: NPD
- Durabilité: NPD

7. EXC -1

8. Fabricant : Palram Canopia Ltd. Teradion Industrial Park, M.P. Misgav 2017400, P.O.B. 53, Israël

9. Importateur et représentant de: Palram DE GmbH, Calbesche Str. 25, 39218 Schönebeck, Deutschland

10. Nom et numéro d'identification de l'organisme notifié: 0906-CPR - 20000210005796

Signé au nom et pour le compte de Palram Canopia Ltd. par:

Teradion Industrial Park, M.P Misgav
2017400, P.O.B 53, Israel

12.01.2023

(Lieu et date d'émission)

PALRAM CANOPIA

(Signature)

LEISTUNGSERKLÄRUNG

Nr. 0202

Jahr des Anhangs: 23

Palram-Canopia Gewächshaus - Hybrid™ / Harmony™ / Mythos™

1. Die Referenz des Produkttyps, für den die Leistungserklärung ausgestellt wurde.

Palram-Canopia Gewächshaus - Hybrid / Harmony / Mythos.

2. Das System oder die Systeme zur Bewertung und Überprüfung der Leistungsbeständigkeit des Bauprodukts, gemäß Anhang V. System 2+

3. Die Referenznummer und das Ausgabedatum der harmonisierten Norm oder der Europäischen Technischen Bewertung, die für die Bewertung jedes wesentlichen Merkmals herangezogen wurde: EN 1090-1:2009+A1:2011

4. Gegebenenfalls die Referenznummer der verwendeten Spezifischen Technischen Dokumentation und die Anforderungen anhand denen der Hersteller erklärt, dass das Produkt entsprechend ist.

- EN1090-1 Ausführung von Stahlkonstruktionen und Aluminiumkonstruktionen - Teil 1: Anforderungen an die Konformitätsbewertung von Bauteilen
- EN1090-3 Ausführung von Stahlkonstruktionen und Aluminiumkonstruktionen - Teil 3: Technische Anforderungen für Aluminiumkonstruktionen
- EN 1990 Basis für Tragwerksplanung
- EN 1991 Einwirkungen auf Tragwerke
- EN 1999 Bemessung von Aluminiumkonstruktionen

5. Der Verwendungszweck oder die Verwendungszwecke des Bauprodukts gemäß der geltenden harmonisierten technischen Spezifikation: Gewächshaus für Endkunde.

6. Die Leistung der wesentlichen Merkmale des Bauprodukts.

- Maß- und Formtoleranzen: EN1090-3 - Anhang G
- Schweißbarkeit: NPD
- Bruchzähigkeit/Schlagzähigkeit: NPD (Aluminiumstruktur)
- Tragfähigkeit:
 - Maximal zulässige Windböen: 21 m/s, definiert als einmal in einem 50-jährigen Wiederkehrwahrscheinlichkeitsintervall, Wert in 10m Entfernung vom Boden, für durchschnittlich 10 Minuten, Geländekategorie II (offene Landschaft)
 - Maximal zulässige Schneelast: 0,50 kN/m², definiert als einmal in einem 50-jährigen Wiederkehrwahrscheinlichkeitsintervall
- Feuerwiderstand: Brandklasse A
- Verformungen und Durchbiegungen: NPD
- Freisetzung von Cadmium und seiner Verbindung: NPD
- Radioaktivität: NPD
- Haltbarkeit: NPD

7. EXC -1

8. Hersteller: Palram Canopia Ltd. Teradion Industrial Park, M.P. Misgav 2017400, P.O.B. 53, Israel

9. Importeur und EU-Vertreter: Palram DE GmbH, Calbesche Str. 25, 39218 Schönebeck, Deutschland

10. Name und Identifikationsnummer der gemeldeten Stelle: 0906-CPR - 20000210005796

Unterschieden für und im Auftrag von Palram Canopia Ltd. durch:

Teradion Industrial Park, M.P Misgav
2017400, P.O.B 53, Israel

12.01.2023

(Ort und Datum der Ausstellung)



PALRAM CANOPIA
(Unterschrift)